

Programmable Multi Axis Controller

# CK3M



Control with  
nanoscale precision



# Maximize your machine's performance

Performing precise linear motor drive control and nanoscale positioning, the PMAC (Programmable Multi Axis Controller) has been appreciated by manufacturers of semiconductor manufacturing equipment and other leading-edge equipment. Omron now offers a next generation motion controller CK3M that packs PMAC's superior motion control capability, multi-vendor connectivity, and flexible development capability into its compact design. The CK3M removes constraints and barriers and maximizes your machine's capabilities.

## Rapid

### [ Nano-level high-precision control ]

Ultra-fast calculation takes high-speed, high-precision control to a new dimension. Its overwhelming calculation speed boosts your machine's precision.

### Ultra-high-speed synchronous control

The CK3M delivers world-beating\*1 output speeds : 50  $\mu$ s/5 axes. Ultra-high-speed feedback control enables precise path control in precision machining.

\*1. Omron survey as of March 2018.

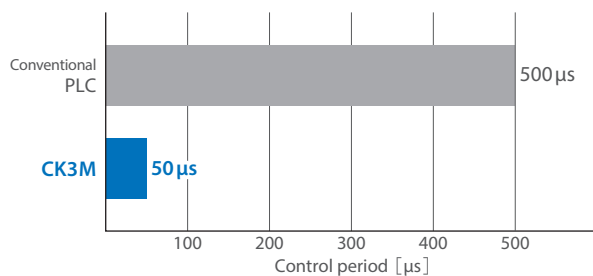

### Fast servo cycle time for precise path control

The CK3M receives a feedback value and generates a command value to adjust to the target value at a high speed, providing more precise path control.

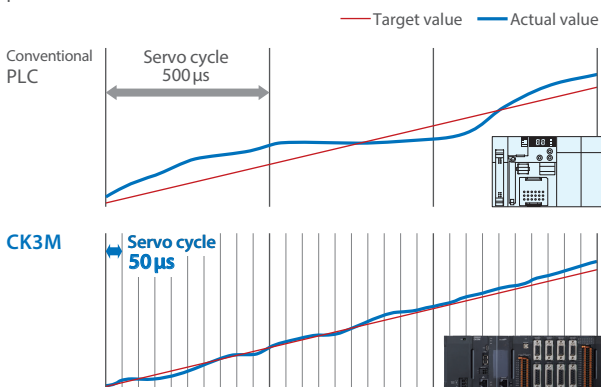

Fast feedback and correction

## Flexible

### [ Optimize system configuration ]

You can freely use multi-vendor actuators and encoders, which maximizes your machine's performance.

### Advanced encoders

The capability to accept the A/B phase signals and parallel binary signals from serial data interfaces enables high-precision positioning using advanced encoders.

### Various actuators

Axes can be controlled by analog Commands(DAC) and Direct PWM. The CK3M can interface with virtually any type of motor including voice coil motors and linear motors to provide precise machine operation.

#### Conventional system

- Fully synchronized control is difficult because multiple controllers are used
- Available actuators are limited depending on controller

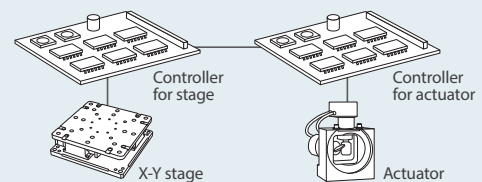

#### CK3M

- One controller provides high-precision synchronous control
- A wide variety of actuators can be controlled, increasing machine performance

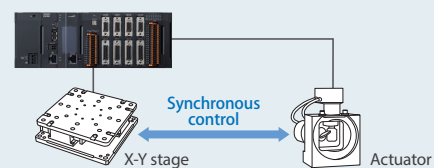

### EtherCAT® interface

The built-in EtherCAT® communications port is used to connect EtherCAT® slaves including servo drives, inverters, vision systems, sensors, and I/O. Flexible systems can be configured.



# Capable

**[ Continuous development through customization ]**

The PMAC architecture with flexible function development capability helps you realize your ideas such as incorporation of your own algorithms.

## Programming flexibility

G-Code, ANSI C, or original programming language allows you to create complex and advanced algorithms.



You can create programs to control robots that follow complex paths.



In addition to customizing standard G-Code functions, you can also incorporate your own G-Code functions.

## Custom servo algorithms

Full closed loop control by servo drives can be incorporated into the controller. You can customize machine control such as vibration suppression optimized for the machine mechanism.

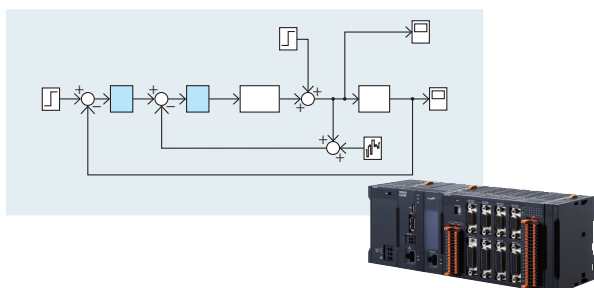

# Easy

**[ Easy to use like a PLC ]**

Its compact design facilitates installation in the control panel. Unit connection without tools and DIN track mounting make installation and replacement more efficient.

## Modular design

The modular design allows you to freely combine the CK3M with CK3W units to enable a variety of applications.



## Tool-free connection & compact size



Units can be easily connected without tools. Its compact design\*2 reduces control panel size.



Approx. **1/3** volume of UMAC, saving space in control panels.

\*2. CK3W-PD + CK3M-CPU + two CK3W-AX

## DIN track mounting



Units can be easily mounted on a DIN track in a control system.

# High-precision control of precision mechanisms

Used in conjunction with advanced actuators, encoders, and precision mechanisms, the CK3M enables a wide variety of applications where both speed and accuracy are required.

## Rapid

Nano-level high-precision control

## Flexible

Optimize system configuration



## Capable

Continuous development through customization

## Easy

Easy to use like a PLC

## Application



### Processing/ pressing machines

High-speed, high-precision processing for electric discharge machines, water jet machines, laser processing machines, grinders, and precision pressing machines

# Mechanism

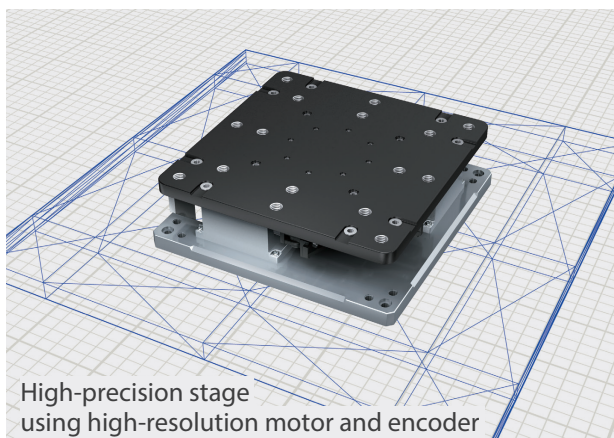

High-precision stage using high-resolution motor and encoder

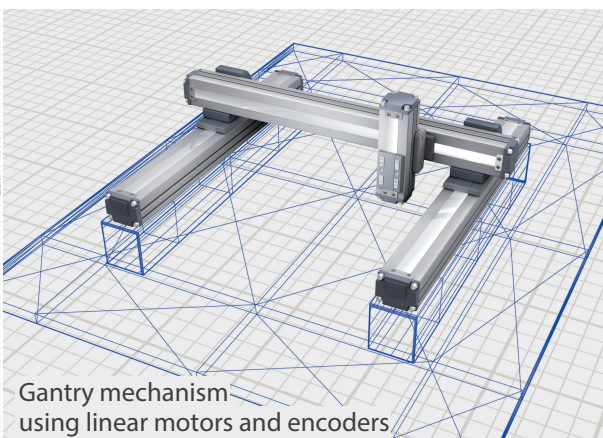

Gantry mechanism using linear motors and encoders

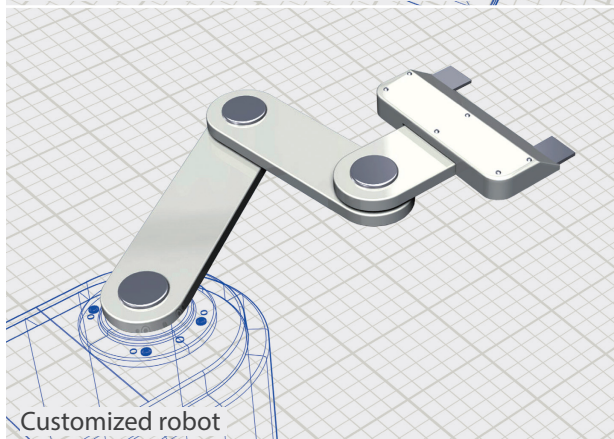

Customized robot

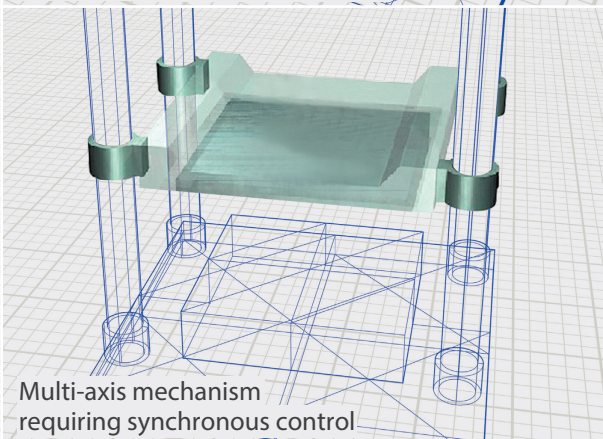

Multi-axis mechanism requiring synchronous control



## Semiconductor/ FPD manufacturing/ inspection machines

Extremely precise motion for exposure machines, coaters, dispensers, and wafer inspection machines

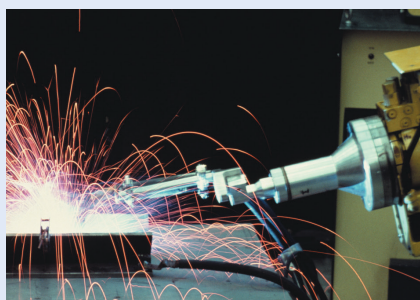

## Robots

Complex mechanical control for machines using customized robots

Integrated development environment (IDE)

# Power PMAC IDE

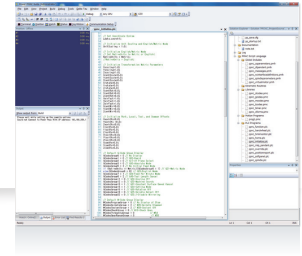

The Power PMAC IDE is an integrated development environment based on Microsoft® Visual Studio® that development engineers use as a development platform around the world. This IDE integrates motion programming for PMAC, motor setup and tuning, debugging, and troubleshooting. Lightweight, sophisticated GUI provides intuitive user operations, which helps you improve application development productivity.

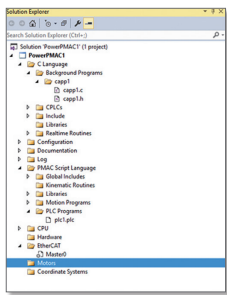

## Microsoft® Visual Studio® based integrated development environment

Assignment settings for CPU, hardware, EtherCAT®, coordinate systems, and motors can be accessed from one screen.



## ANSI C or original programming language

In addition to programming in ANSI C and C-language like original programming language, G-Code can be used to write subroutines for G-Code actions.

### Easy tuning

Autotuning facilitates tuning of motors. You can fine tune motors through intuitive operations.

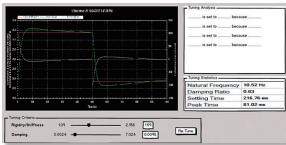

### Simple setting

Just follow the workflow to set up motors.

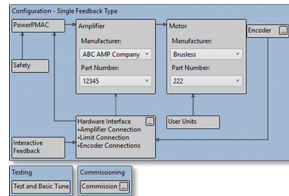

### Troubleshooting

Possible solutions to your problems are suggested.

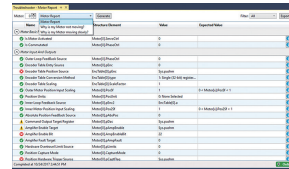

### Debugger

It provides the Microsoft® Visual Studio® style debugger for Script PLC programs and C background programs.

### IP Protection

IP Protection allows engineers to protect their intellectual property by encrypting script programs

An engineer can encrypt the script programs per file and pass the project on to another engineer. The engineer who takes the project can add their own logic but cannot list or view the code encrypted by another engineer. The encryption is three-level password protected: OEM builders, independent integrators, and users can share a project securely and flexibly.

### Three-level IP Protection

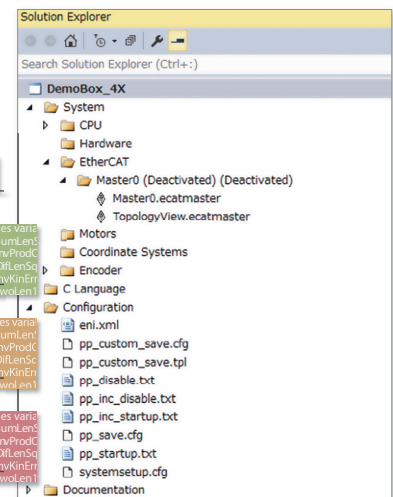
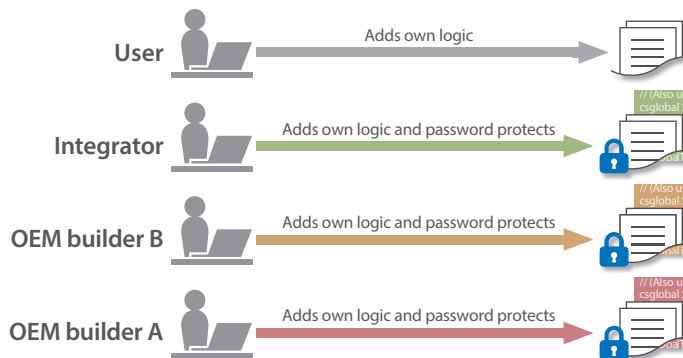

## Specifications

Motion control	Max. no. of controlled axes	24 (4 axes/axial interface unit x 4 units : 16, EtherCAT : 8)
	Motion control period	50 μs / 5 axes or more
	Control method	Analog (Filtered PWM, True DAC), pulse ,Direct PWM
Interface		Ethernet port, EtherCAT® port (CPU option)
Feedback		AB phase, serial encoders
Memory	RAM	1 GB
	Flash	1 GB
Number of connectable CK3W Units	CPU Rack	Up to four CK3W Units (or up to two CK3W-AX Units)
	Expansion Rack	Up to four CK3W Units (or up to two CK3W-AX Units)

### System configuration

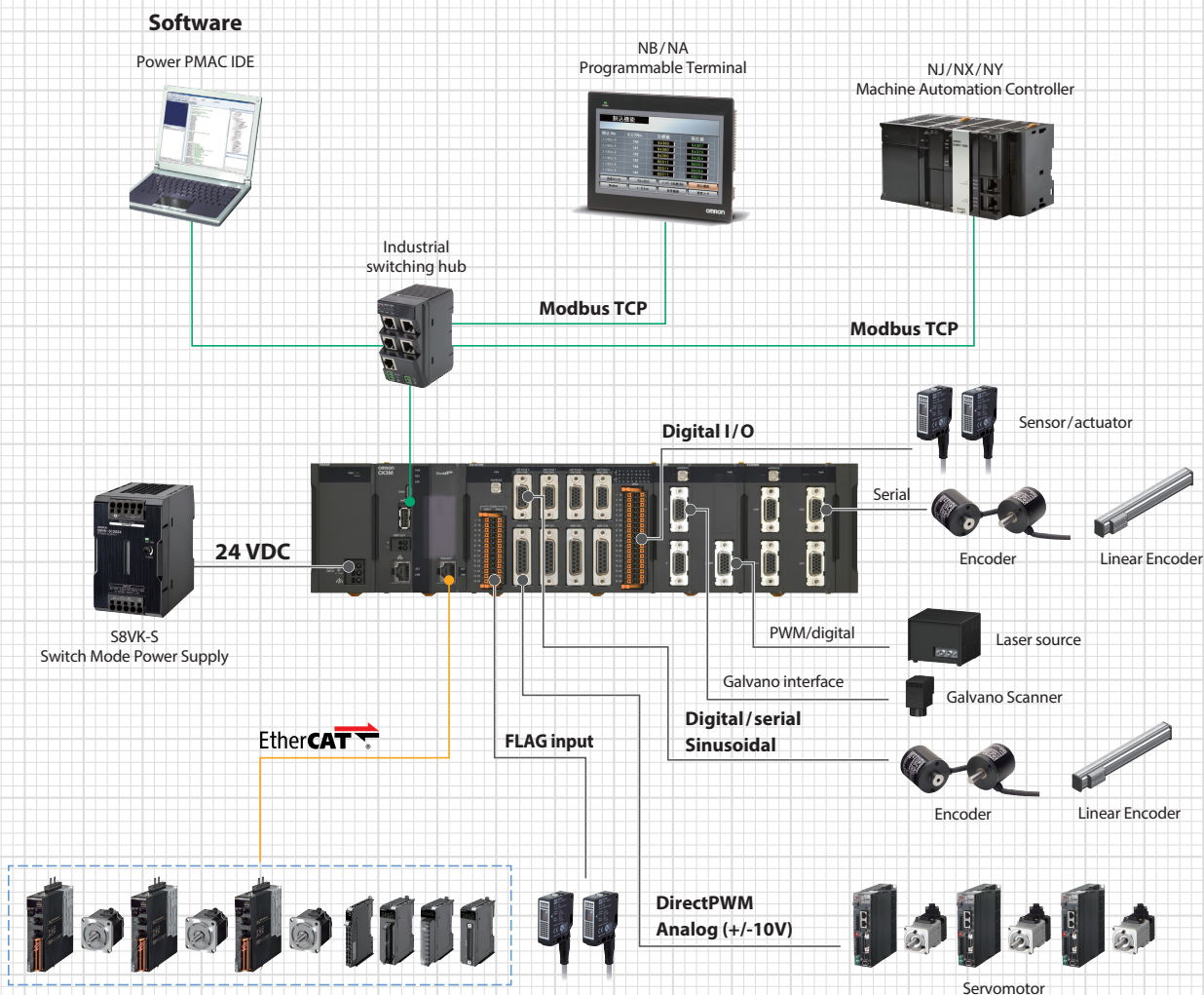

# PMAC Series family

## ■ Standard Models

### CPU Units

Product name	Memory capacity	EtherCAT® port	Max. no. of controlled axes via EtherCAT® port	Expansion	Model
CK3M-CPU1□1 CPU Unit*	RAM: 1 GB Built-In flash memory: 1 GB	None	—	One expansion rack can be connected using the expansion master unit and expansion slave unit	CK3M-CPU101
		EtherCAT®: 1 port (DC sync)	4		CK3M-CPU111
			8		CK3M-CPU121

\* One End Cover is provided with the CK3M-CPU1□1 CPU Unit. The CK3W-TER11 End Cover for CK3M-CPU1□1 is sold separately if required.

### Axial Interface Units

Product name	Amplifier interface	Encoder interface	Output type	Model	
Axial Interface Unit	DirectPWM output	Digital quadrature encoder/ serial encoder	NPN type	CK3W-AX1313N	
	DA output (Filtered PWM)			CK3W-AX1414N	
	DA output (True DAC)			CK3W-AX1515N	
	DirectPWM output	Sinusoidal encoder/ Serial encoder		CK3W-AX2323N	
	DirectPWM output	Digital quadrature encoder/ serial encoder		PNP type	CK3W-AX1313P
	DA output (Filtered PWM)				CK3W-AX1414P
	DA output (True DAC)		CK3W-AX1515P		
	DirectPWM output	Sinusoidal encoder/ Serial encoder	CK3W-AX2323P		

### Power Supply Unit

Product name	Specifications	Model
Power Supply Unit for CK3M-CPU1□1	Rated output voltage: 5VDC / 24VDC, Maximum output power: 5VDC 23W, 24VDC 55W	CK3W-PD048

### Digital I/O Units

Product name	Number of inputs	Number of outputs	I/O type	Model
Digital I/O Unit	16 points	16 points	NPN	CK3W-MD7110
			PNP	CK3W-MD7120

### Analog Input Units

Product name	Input range	Number of inputs	Model
Analog Input Unit	-10 to 10 V	4 points	CK3W-AD2100
		8 points	CK3W-AD3100

### Encoder Input Unit

Product name	Encoder type	Number of channels	Protocol	Model
Encoder Input Unit	Serial encoder	4 channels	BiSS-C, Endat2.2, and R88M-1L□/-1M□ Motor built-in encoder	CK3W-ECS300

### Laser Interface Units

Product name	Communications method	Laser output	Model
Laser Interface Units	XY2-100	PWM output	CK3W-GC1100
		PWM output, TCR output	CK3W-GC1200
	SL2-100	PWM output	CK3W-GC2100
		PWM output, TCR output	CK3W-GC2200

### Expansion Master Unit and Expansion Slave Unit

Product name	Function	Model
Expansion Master Unit	Connect the Expansion Master Unit adjacent to the right side of the CPU Unit.	CK3W-EXM01
Expansion Slave Unit	Connect the Expansion Slave Unit adjacent to the right side of the Power Supply Unit.	CK3W-EXS02
Expansion cable	For connection between the Expansion Master Unit and the Expansion Slave Unit (0.3m)	CK3W-CAX003A

- Microsoft® and Visual Studio® are either registered trademarks or trademarks of Microsoft Corporation in the United States and/or other countries.
- EtherCAT® is a registered trademark and patented technology, licensed by Beckhoff Automation GmbH, Germany.
- Microsoft product screen shot(s) reprinted with permission from Microsoft Corporation.
- Other company names and product names in this document are the trademarks or registered trademarks of their respective companies.
- The product photographs and figures that are used in this catalog may vary somewhat from the actual products.
- PMAC is an abbreviation for Programmable Multi Axis Controller.
- Some images are used under license from Shutterstock.com.

Note: Do not use this document to operate the Unit.

**OMRON Corporation** Industrial Automation Company  
Kyoto, JAPAN

Contact: [www.ia.omron.com](http://www.ia.omron.com)

#### Regional Headquarters

**OMRON EUROPE B.V.**  
Wegalaan 67-69, 2132 JD Hoofddorp  
The Netherlands  
Tel: (31)2356-81-300/Fax: (31)2356-81-388

**OMRON ELECTRONICS LLC**  
2895 Greenspoint Parkway, Suite 200  
Hoffman Estates, IL 60169 U.S.A.  
Tel: (1) 847-843-7900/Fax: (1) 847-843-7787

**OMRON ASIA PACIFIC PTE. LTD.**  
No. 438A Alexandra Road # 05-05/08 (Lobby 2),  
Alexandra Technopark,  
Singapore 119967  
Tel: (65) 6835-3011/Fax: (65) 6835-2711

**OMRON (CHINA) CO., LTD.**  
Room 2211, Bank of China Tower,  
200 Yin Cheng Zhong Road,  
PuDong New Area, Shanghai, 200120, China  
Tel: (86) 21-5037-2222/Fax: (86) 21-5037-2200

Authorized Distributor:

© OMRON Corporation 2018-2022 All Rights Reserved.  
In the interest of product improvement,  
specifications are subject to change without notice.  
**CSM\_1\_7**  
Cat. No. R196-E1-07

0322 (0318)