

AC Servo System 1S-series with Safety Functionality

R88M-1A□/R88D-1SAN□-ECT**Safer environment and
higher productivity**

- 8 safety functions according to SIL3/PLe (STO, SS1, SS2, SOS, SLS, SLP, SDI, SBC)
- Safety-over-EtherCAT (FsoE)
- Power, encoder and brake in one cable
- 400-V models for higher machine efficiency
- Suppresses vibration of low-rigidity machines during acceleration/deceleration
- EtherCAT communications cycle of 125 μ s
- TDF control structure for easy adjustment
- Battery-free absolute encoder



AC Servo System 1S-series with Safety Functionality

System Configuration

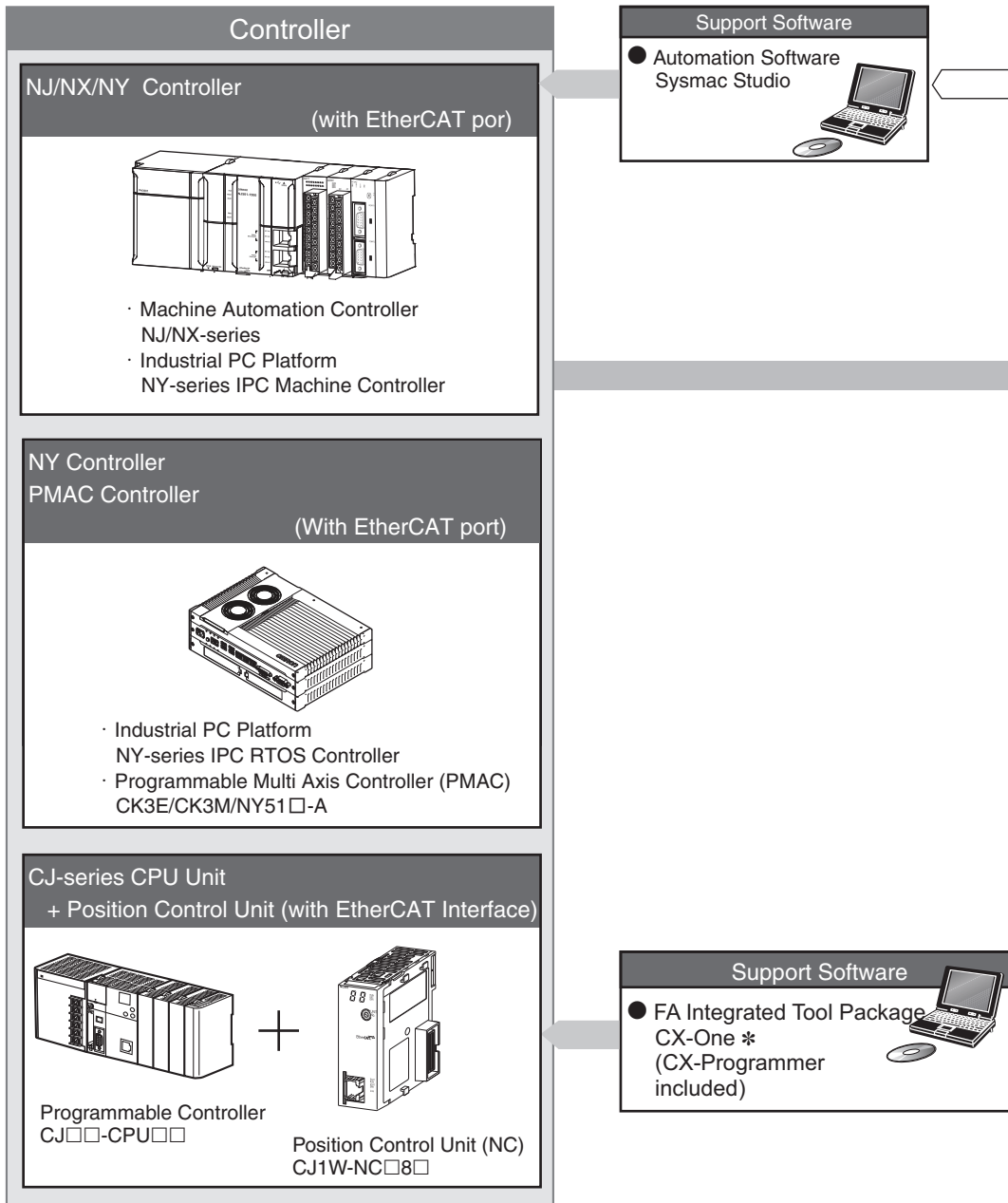

* You cannot use the CX-One to make the settings of 1S-series Servo Drives Advance type. Obtain the Sysmac Studio.

Note: PMAC is an abbreviation for Programmable Multi Axis Controller.

AC Servo System 1S-series with Safety Functionality

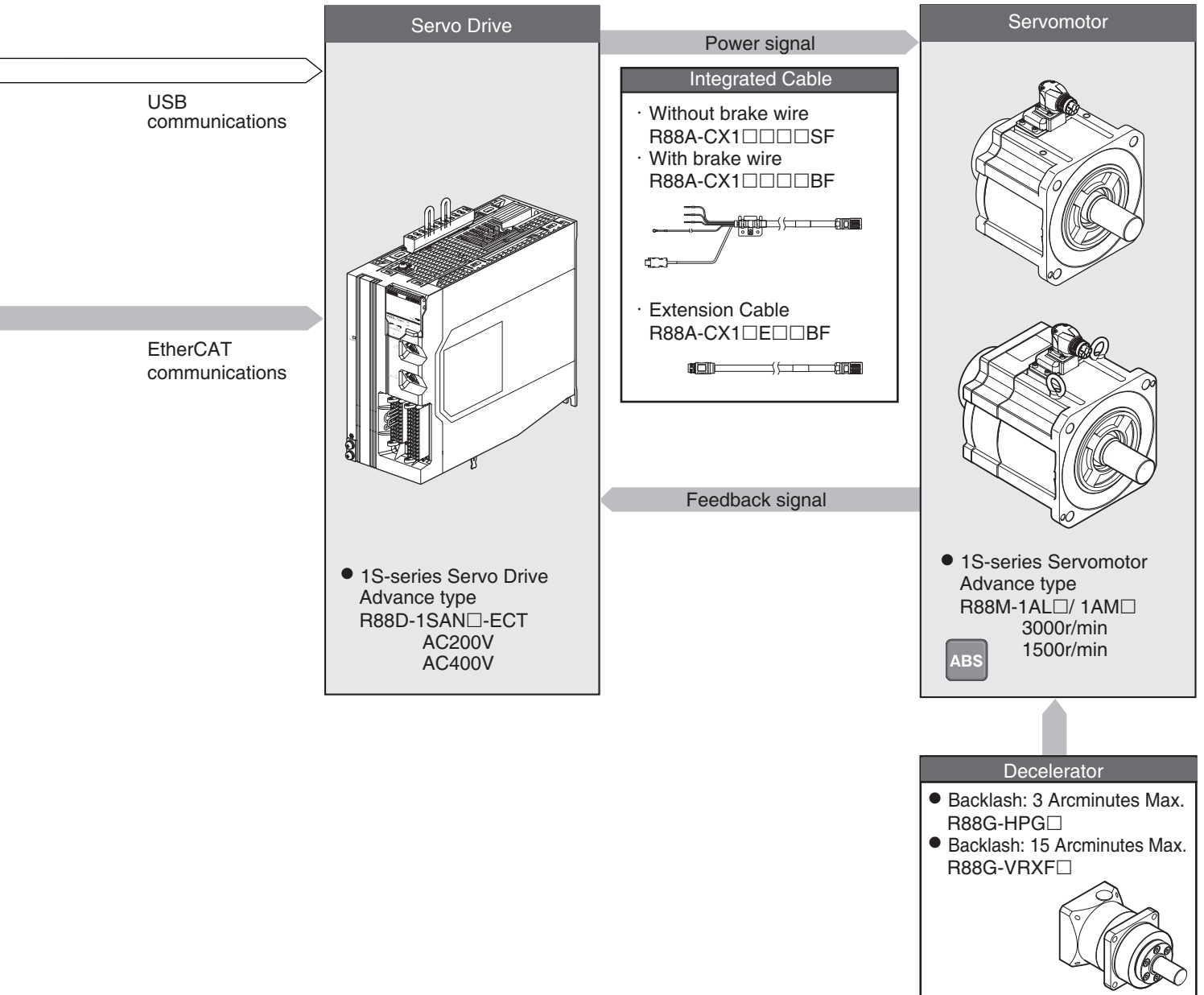

R88D-1SAN□-ECT

Contents

- Ordering Information
- Specifications
- EtherCAT Communication Specifications
- Outline of Safety Functions
- Version Information
- Names and Functions
- Dimensions



Ordering Information

Refer to the Ordering Information.

Specifications

General Specifications

Item		Specifications	
Operating ambient temperature and humidity		0 to 55°C, 90% max. (with no condensation)	
Storage ambient temperature and humidity		-20 to 65°C, 90% max. (with no condensation)	
Operating and storage atmosphere		No corrosive gases	
Operating altitude		1,000 m max.	
Vibration resistance		10 to 60 Hz and at an acceleration of 5.88 m/s ² or less (Not to be run continuously at the resonance frequency)	
Insulation resistance		Between power supply terminals/power terminals and PE terminals: 0.5 MΩ min. (at 500 VDC)	
Dielectric strength		Between power supply terminals/power terminals and PE terminals: 1,500 VAC for 1 min (at 50/60 Hz)	
Protective structure		IP20 (Built into IP54 panel)	
International standard	EU Directives	EMC Directive	EN 61800-3 second environment, C3 category (EN 61000-6-7; Functional Safety)
		Low Voltage Directive	EN61800-5-1
		Machinery Directive	EN ISO 13849-1, EN61508, EN62061, EN61800-5-2
	UL standards		UL 61800-5-1
	CSA standards		CSA C22.2 No. 274
	Korean Radio Regulations (KC)		Compliant
	Australian EMC Labeling Requirements (RCM)		Compliant
	EAC requirements		Compliant
	SEMI standards		Can conform to the standard for momentary power interruptions (for no-load operation).
	Ship standards (NK/LR)		Not compliant

- Note:**
1. The above items reflect individual evaluation testing. The results may differ under compound conditions.
 2. Disconnect all connections to the Servo Drive before attempting a megger test (insulation resistance measurement) on a Servo Drive. Not doing so may result in the Servo Drive failure. Do not perform a dielectric strength test on the Servo Drive. Internal elements may be damaged.

The detail of Machinery Directive is as follows:

The STO function via safety input signals: EN ISO13849-1 (Cat3 PL_e), EN61508, EN62061, EN61800-5-2 (SIL3)

The safety function via EtherCAT communications: EN ISO 13849-1 (STO/SS1/SBC: Cat.3 PL_e, SS2/SLS/SDI/SOS/SLP: Cat.3 PL_e), EN61508, EN62061, EN61800-5-2

AC Servo System 1S-series with Safety Functionality

Characteristics

200-VAC Input Models

Servo Drive model (R88D-)			1SAN02H-ECT	1SAN04H-ECT	1SAN08H-ECT
Item			200 W	400 W	750 W
Input	Main circuit	Power supply voltage	Single-phase and 3-phase 200 to 240 VAC (170 to 252 V) *1		
		Frequency	50/60 Hz (47.5 to 63 Hz) *1		
	Control circuit	Power supply voltage	24 VDC (21.6 to 26.4 V)		
		Current consumption *2	700 mA		
	Rated current [A (rms)] (Main circuit power supply voltage: 240 VAC)	Singlephase	2.7	4.6	7.3
3-phase		1.5	2.7	4.0	
Output	Rated current [A (rms)]	1.5	2.5	4.6	
	Maximum current [A (rms)]	5.6	9.1	16.9	
Heating value [W]	Main circuit	17.0	25.0	42.0	
	Control circuit	11.9	11.9	14.5	
Applicable Servomotor rated output [W]		200	400	750	
3,000-r/min Servomotor (R88M-)	Batteryless 20-bit ABS	1AM20030T	1AM40030T	1AM75030T	
Hold time at momentary power interruption (Main circuit power supply voltage: 200 VAC)		10 ms (Load condition: rated output) *4			
SCCR [A (rms)]		5000			
Weight [kg]		2.6	2.6	2.6	

Servo Drive model (R88D-)			1SAN10H-ECT	1SAN15H-ECT	1SAN20H-ECT	1SAN30H-ECT
Item			1 kW	1.5 kW	2 kW	3 kW
Input	Main circuit	Power supply voltage	3-phase 200 to 240 VAC (170 to 252 V) *1	Single-phase and 3-phase 200 to 240 VAC (170 to 252 V) *1	3-phase 200 to 240 VAC (170 to 252 V) *1	
		Frequency	50/60 Hz (47.5 to 63 Hz) *1			
	Control circuit	Power supply voltage	24 VDC (21.6 to 26.4 V)			
		Current consumption *2	700 mA	1000 mA		
	Rated current [A (rms)] (Main circuit power supply voltage: 240 VAC)	Singlephase	---	15.7	---	---
3-phase		5.8	9.0	13.0	15.9	
Output	Rated current [A (rms)]	7.7	9.7	16.2	22.3	
	Maximum current [A (rms)]	16.9	28.4	41.0	54.7	
Heating value [W]	Main circuit *3	49.0	88.0	140.0	150.0	
	Control circuit	14.5	22.4	22.4	22.4	
Applicable Servomotor rated output [W]		1,000	1,500	2,000	3,000	
3,000-r/min Servomotor (R88M-)	Batteryless 20-bit ABS	1AL1K030T	1AL1K530T	1AL2K030T	1AL2K630T	
1,500-r/min Servomotor (R88M-)	Batteryless 20-bit ABS	---	1AM1K515T	---	1AM2K715T	
Hold time at momentary power interruption (Main circuit power supply voltage: 200 VAC)		10 ms (Load condition: rated output) *4				
SCCR [A (rms)]		5000				
Weight [kg]		2.6	4.2	4.2	4.2	

*1. The values outside parentheses indicate the rated value, and the values inside parentheses indicate the range of acceptable variation.

*2. Select a DC power supply in consideration of the current values that are specified in the current consumption. The rated current value that is printed on the product nameplate is a condition to apply the 1S-series product for the UL/Low Voltage Directive. Therefore, you do not need to consider it when you select a DC power supply for each model.

*3. This is the maximum heating value in applicable Servomotors.

Refer to *Relationship between Servo Drive, Servomotors and the Main Circuit Heating Value* on page 6 for the heating value of each applicable Servomotor.

*4. It is a hold time at momentary power interruption. Use a DC power supply to fulfill the following conditions so that the power supply of the control circuit is held during momentary power interruption.

Reinforced insulation or double insulation, and the output hold time of 10 ms or more

AC Servo System 1S-series with Safety Functionality

400-VAC Input Models

Use a neutral grounded 400 VAC 3-phase power supply for the 400 VAC input models.

Servo Drive model (R88D-)			1SAN10F-ECT	1SAN15F-ECT	1SAN20F-ECT	1SAN30F-ECT
Item			1 kW	1.5 kW	2 kW	3 kW
Input	Main circuit	Power supply voltage	3-phase 380 to 480 VAC (323 to 504 V) *1			
		Frequency	50/60 Hz (47.5 to 63 Hz) *1			
	Control circuit	Power supply voltage	24 VDC (21.6 to 26.4 V)			
		Current consumption *2	1000 mA			
Output	Rated current [A (rms)] (Main circuit power supply voltage: 480 VAC)	3-phase	3.1	4.3	6.5	8.4
		Rated current [A (rms)]	4.1	4.7	7.8	11.3
Heating value [W]	Main circuit *3	Rated current [A (rms)]	9.6	14.1	19.8	28.3
		Control circuit	56.0	81.0	120.0	150.0
Applicable Servomotor rated output [W]	Control circuit	Rated current [A (rms)]	22.4	22.4	22.4	22.4
		Control circuit	1,000	1,500	2,000	3,000
3,000-r/min Servomotor (R88M-)	Batteryless 20-bit ABS	1AL75030C 1AL1K030C	1AL1K530C	1AL2K030C	1AL3K030C	
1,500-r/min Servomotor (R88M-)	Batteryless 20-bit ABS	---	1AM1K515C	---	1AM3K015C	
Hold time at momentary power interruption (Main circuit power supply voltage: 400 VAC)			10 ms (Load condition: rated output) *4			
SCCR [A (rms)]			5000			
Weight [kg]			4.2	4.2	4.2	4.2

*1. The values outside parentheses indicate the rated value, and the values inside parentheses indicate the range of acceptable variation.

*2. Select a DC power supply in consideration of the current values that are specified in the current consumption.

The rated current value that is printed on the product nameplate is a condition to apply the 1S-series Servo Drive Advance type product for the UL/Low Voltage Directive.

Therefore, you do not need to consider it when you select a DC power supply for each model.

*3. This is the maximum heating value in applicable Servomotors.

Refer to *Relationship between Servo Drive, Servomotors and the Main Circuit Heating Value* on page 6 for the heating value of each applicable Servomotor.

*4. It is a hold time at momentary power interruption. Use a DC power supply to fulfill the following conditions so that the power supply of the control circuit is held during momentary power interruption.

Reinforced insulation or double insulation, and the output hold time of 10 ms or more

Relationship between Servo Drive, Servomotors and the Main Circuit Heating Value

Servo Drive model	Servomotor model	Main circuit heating value [W]
R88D-1SAN15H-ECT	R88M-1AL1K530T-□	88
	R88M-1AM1K515T-□	69
R88D-1SAN30H-ECT	R88M-1AL2K630T-□	150
	R88M-1AM2K715T-□	150
R88D-1SAN10F-ECT	R88M-1AL75030C-□	55
	R88M-1AL1K030C-□	56
R88D-1SAN15F-ECT	R88M-1AL1K530C-□	81
	R88M-1AM1K515C-□	52
R88D-1SAN30F-ECT	R88M-1AL3K030C-□	150
	R88M-1AM3K015C-□	140

Outline of Safety Functions

Details about Safety Functions

Function	Description
Safe torque off (STO)	The function is used to cut off a motor current and stop the motor.
Safe stop 1 (SS1)	This function is used to stop a motor by activating STO function at any timing after receiving a command from a safety controller.
Safes stop 2 (SS2)	This function is used to monitor a motor's stop by activating SOS function at any timing after receiving a command from a safety controller.
Safe operating stop (SOS)	This function is used to monitor that a motor stops at any positions. Both a position and velocity are monitored. Excessive limit value error occurs when the motor operates from a position where it stops.
Safely-limited speed (SLS)	This function is used to monitor a safety present motor velocity. When the safety present motor velocity exceeds the velocity limit for monitoring, excessive limit value error occurs.
Safely-limited position (SLP)	This function is used to monitor current positions. Excessive limit value error occurs when the positions surpass a range for monitoring.
Safe direction (SDI)	This function is used to monitor motor's rotating direction. Excessive limit value error occurs when a motor rotates toward the banned rotating direction.
Safe brake control (SBC)	This function is used to provide safety output for a holding brake. The function can be used with STO, SS1 functions and the brake operation.

Safety Servo Drives have two type STO functions. Use either or both functions according to configuration of safety devices.

- STO function by safety input signals
- STO function via EtherCAT communications

When you use just STO function by safety input signals, you do not need a setting related EtherCAT network.

Achievable safety levels for each safety function at maximum are shown as the below table:

Function	Achievable safety level	Function	Achievable safety level
STO	SIL3/PLe	SLS	SIL3/PLe *1
SS1	SIL3/PLe	SLP	SIL3/PLe *2
SS2	SIL3/PLe	SDI	SIL3/PLe *1
SOS	SIL3/PLe *1	SBC	SIL3/PLe *3

*1. Achievable safety level varies in a basic control for use.

*2. Achievable safety level varies in Safety Origin Position Determination Method or SOPT input devices for use.

*3. Achievable safety level varies in Brake structure.

Refer to the *AC Servomotors/Servo Drives 1S-series with Built-in EtherCAT® Communications and Safety Functionality User's Manual* (Cat. No. I621) for details.

Configuration for Safety System

To make devices enter into safe state, a combined control among a safety controller, a standard controller and a Servo Drive is required.

Typical roles of each device are shown as below.

Device	Role
Safety Controller	<ul style="list-style-type: none"> • Monitor safety input and output. • Notify a standard controller of states of safety input and output. • Issue commands to activate and interrupt safety functions to a Servo Drive. • Issue commands to reset errors of safety functions to a Servo Drive.
Standard Controller	<ul style="list-style-type: none"> • Issue commands to turn Servo ON/OFF and reset errors to a Servo Drive. • Issue command to control a specified position, velocity and torque of a Servomotor to a Servo Drive.
Servo Drive	<ul style="list-style-type: none"> • Turn Servo ON/OFF and reset errors after receiving commands from a standard controller. • Control a Servomotor after receiving commands from a standard controller. • Activate and interrupt safety functions after receiving commands from a safety controller. • Reset errors of safety functions after receiving commands from a safety controller. • Stop a Servomotor when an error occurs.

A procedure for the control is described as follow:

1. A safety controller detects the following cases with a safety sensor and a safety switch.
 - When workers entered exclusion zones
 - When workers are about to touch hazardous sites of the device
 - When workers come closely to the devices for the purpose of a check of devices/products, maintenance and supply of materials
2. A safety controller notifies a standard controller of the detected data.
3. A standard controller issues commands to decelerate and stop a Servomotor to a Servo Drive. At the same time, a safety controller issues commands to activate safety functions for use to a Servo Drive.
4. A Servo Drive receives and executes the commands from both controllers.

AC Servo System 1S-series with Safety Functionality

Thus, a safety controller and a standard controller must issue commands to a Servo Drive at an appropriate timing according to states of switches, sensors and devices, and then have the programs to issue the commands.

To secure the combined operation between a safety controller and a standard controller, design programs for each device with consideration of the following times. Without this consideration of the times mentioned earlier, when safety functions are activated, STO may be active and an excessive limit value error (Error display No.71.03) may occur.

- Time until safety functions starts the activations

It refers to "Time until a safety controller issues command to activate safety functions + Delay time of safety functions".

- Delay time of safety functions

Time until STO becomes active or a Servo Drive starts monitoring after it receives commands of safety functions.

Refer to the *AC Servomotors/Servo Drives 1S-series with Built-in EtherCAT® Communications and Safety Functionality User's Manual* (Cat. No. I621) for details.

This section describes a flow of control of each device with an example such as SLS function.

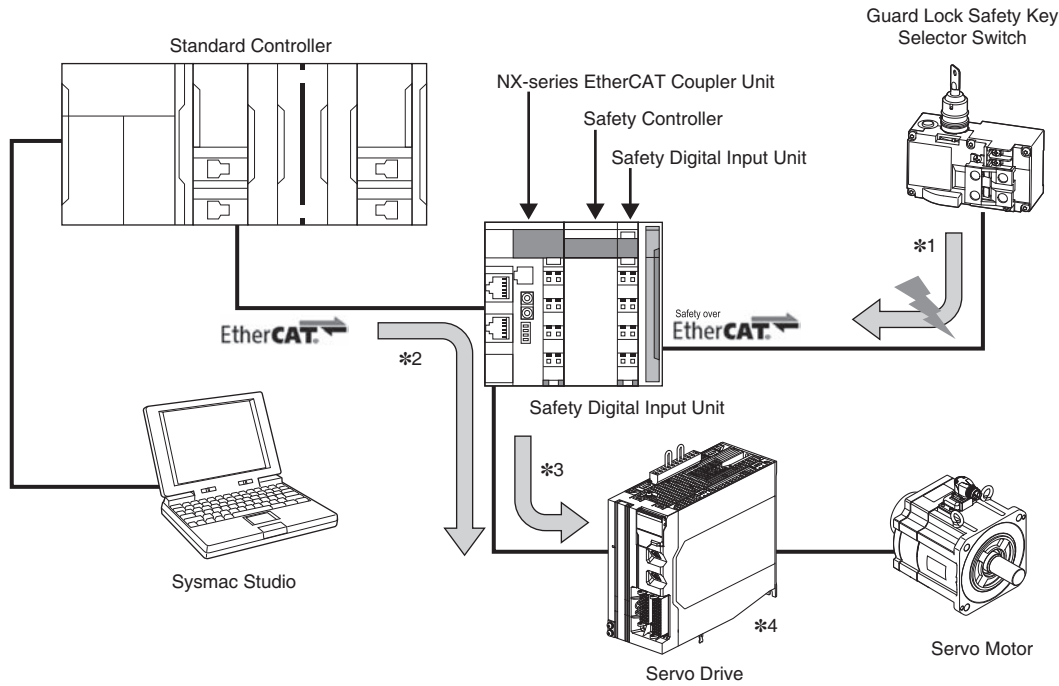

Safety system configuration equipment	Model
Standard Controller	NX701
EtherCAT Coupler Unit	NX-ECC201 NX-ECC202
Safety Controller	NX-SL3300 NX-SL3500
Safety Digital Input Unit	NX-SIH400
Guard Lock Safety Key Selector Switch	A22LK
Servo Drive	R88D-1SAN

***1.** The safety key selector switch and the safety controller detect that workers come closer to devices due to the reason such as maintenance, etc.

***2.** The standard controller reads data from the safety controller and checks a switch to maintenance mode. In such case, it issues a command to decelerate a velocity of the Servomotor and gives the command to the Servo Drive.

***3.** The safety controller issues/gives a command to activate SLS function to the Servo Drive.

***4.** The Servo Drive controls the motor's deceleration, following the command from the standard controller. In addition, it activates SLS function after receiving the command to activate SLS from the safety controller.

AC Servo System 1S-series with Safety Functionality

EtherCAT Communications Specifications

Item	Specifications
Communications standard	IEC 61158 Type 12, IEC 61800-7 CiA 402 Drive Profile
Physical layer	100BASE-TX (IEEE802.3)
Connectors	RJ45 × 2 (shielded) ECAT IN: EtherCAT input ECAT OUT: EtherCAT output
Communications media	Recommended media: Twisted-pair cable, which is doubly shielded by the aluminum tape and braid, with Ethernet Category 5 (100BASE-TX) or higher
Communications distance	Distance between nodes: 100 m max.
Process data	Fixed PDO mapping Variable PDO mapping
Mailbox (CoE)	Emergency messages, SDO requests, SDO responses, and SDO information
Synchronization mode and communications cycle	DC Mode (Synchronous with Sync0 Event) Communications cycle: 125 μs, 250 μs, 500 μs, 750 μs, 1 to 10 ms (in 0.25 ms increments) Free Run Mode
Indicators	ECAT-L/A IN (Link/Activity IN) × 1 ECAT-L/A OUT (Link/Activity OUT) × 1 ECAT-RUN × 1 ECAT-ERR × 1
CiA 402 Drive Profile	<ul style="list-style-type: none"> • Cyclic synchronous position mode • Cyclic synchronous velocity mode • Cyclic synchronous torque mode • Profile position mode • Profile velocity mode • Homing mode • Touch probe function • Torque limit function

Version Information

The following table gives the relationship between unit versions of 1S-series Servo Drives Advance type and the corresponding Sysmac Studio versions.

Unit version	Sysmac Studio
Version 1.0 *	Version 1.44.1 or higher

* Sysmac Studio version 1.44 or higher enables you to use the cable redundancy function and configure a ring topology.

AC Servo System 1S-series with Safety Functionality

Part Names

Servo Drive Part Names

R88D-1SAN02H-ECT/-1SAN04H-ECT/-1SAN08H-ECT/-1SAN10H-ECT

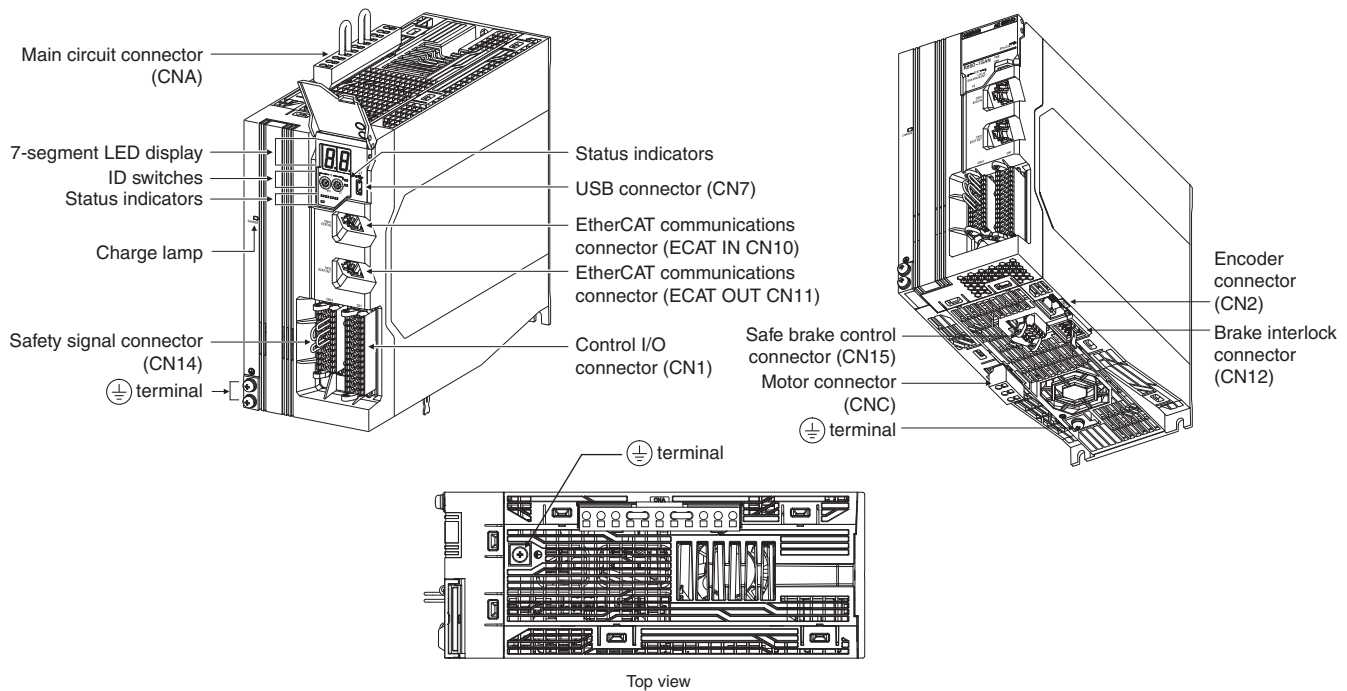

R88D-1SAN15H-ECT/-1SAN20H-ECT/-1SAN30H-ECT/-1SAN10F-ECT/
-1SAN15F-ECT/-1SAN20F-ECT/-1SAN30F-ECT

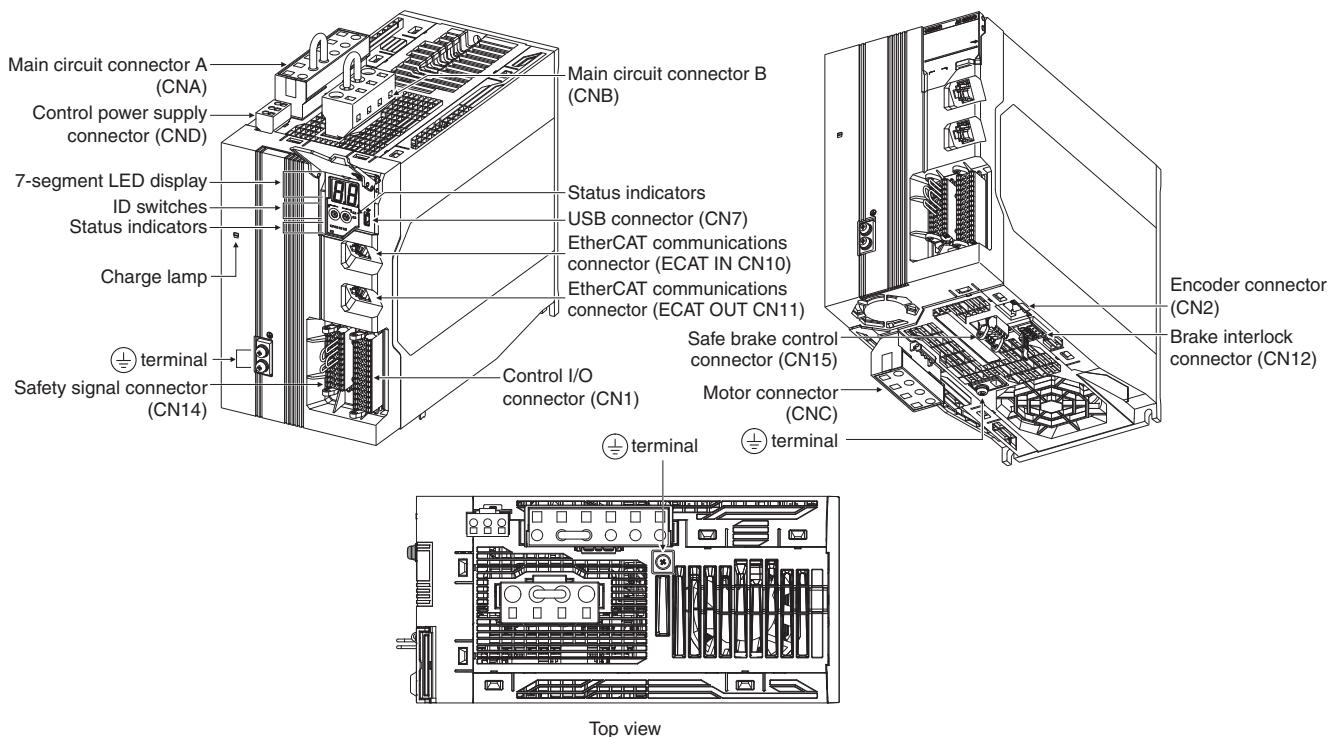

Servo Drive Functions

Status Indicators

The following seven indicators are mounted.

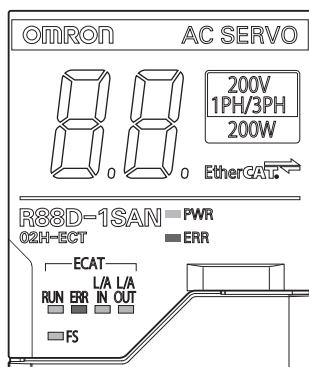

Name	Color	Description
PWR	Green	Displays the status of control power supply.
ERR	Red	Gives the Servo Drive error status.
ECAT-RUN	Green	Displays the EtherCAT communications status.
ECAT-ERR	Red	
ECAT-L/A IN, ECAT-L/A OUT	Green	Lights or flashes according to the status of a link in the EtherCAT physical layer.
FS	Red/green	Displays the safety communications status.

7-segment LED Display

A 2-digit 7-segment LED display shows error numbers, the Servo Drive status, and other information.

ID Switches

Two rotary switches (0 to F hex) are used to set the EtherCAT node address.

Charge Lamp

Lights when the main circuit power supply carries electric charge.

Control I/O Connector (CN1)

Used for connecting command input signals and I/O signals to an external device.

Encoder Connector (CN2)

Connector for the encoder installed in the Servomotor.

EtherCAT Communications Connectors (ECAT IN CN10, ECAT OUT CN11)

These connectors are for EtherCAT communications.

USB Connector (CN7)

USB-Micro B Communications connector for the computer. This connector enables USB 2.0 Full Speed (12 Mbps) communications.

Brake Interlock Connector (CN12)

Used for brake interlock signals.

Main Circuit Connector (CNA)

Connector for the main circuit power supply input, control power supply input, external regeneration resistor, and DC reactor.

Applicable models: R88D-1SAN02H-ECT/-1SAN04H-ECT/-1SAN08H-ECT/-1SAN10H-ECT

Main Circuit Connector A (CNA)

Connector for the main circuit power supply input and external regeneration resistor.

Applicable models: R88D-1SAN15H-ECT/-1SAN20H-ECT/-1SAN30H-ECT/-1SAN10F-ECT/-1SAN15F-ECT/-1SAN20F-ECT/-1SAN30F-ECT

AC Servo System 1S-series with Safety Functionality

Main Circuit Connector B (CNB)

Connector for a DC reactor.

Applicable models: R88D-1SAN15H-ECT/-1SAN20H-ECT/-1SAN30H-ECT/-1SAN10F-ECT/-1SAN15F-ECT/-1SAN20F-ECT/-1SAN30F-ECT

Control Power Supply Connector (CND)

Connector for control power supply input.

Applicable models: R88D-1SAN15H-ECT/-1SAN20H-ECT/-1SAN30H-ECT/-1SAN10F-ECT/-1SAN15F-ECT/-1SAN20F-ECT/-1SAN30F-ECT

Motor Connector (CNC)

Connector for the power line to the phase U, V, and W of the Servomotor.

The connector differs depending on the model.

Safety Signal Connector (CN14)

Used for connecting a safety device. The short-circuit wire is installed on the safety signals before shipment.

Safe Brake Control Connector (CN15)

Used for connecting to the brake to be controlled by safe brake control.

⊕ Terminal

The number of ⊕ terminals of the Servo Drives and their connection targets are as follows.

Servo Drive model	Number of ⊕ terminals	Connection to
R88D-1SAN02H-ECT/-1SAN04H-ECT/-1SAN08H-ECT/ -1SAN10H-ECT	1 on top	PE wire of the main circuit power supply cable. FG wire inside the control panel, and FG wire for the Integrated Cable and Shield Clamp.
	2 on front	
	1 on bottom	
R88D-1SAN15H-ECT/-1SAN20H-ECT/-1SAN30H-ECT/ -1SAN10F-ECT/-1SAN15F-ECT/-1SAN20F-ECT/ -1SAN30F-ECT	1 on top	PE wire of the main circuit power supply cable. FG wire inside the control panel and the Shield Clamp.
	2 on front	
	1 on bottom	

AC Servo System 1S-series with Safety Functionality

Dimensions

(Unit: mm)

Single-phase/3-phase 200 VAC: R88D-1SAN02H-ECT/-1SAN04H-ECT/-1SAN08H-ECT (200 to 750 W)
 3-phase 200 VAC: R88D-1SAN10H-ECT (1 kW)

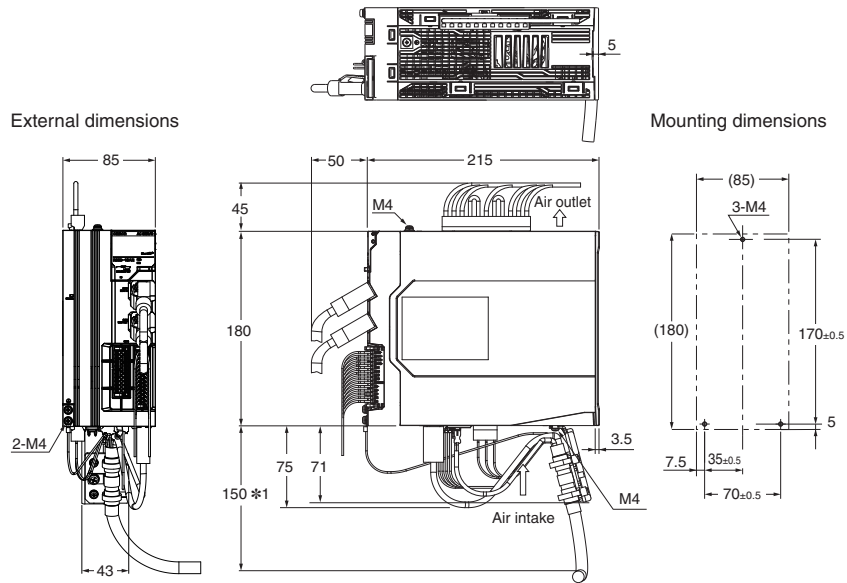

*1. The value is 180 for R88D-1SAN10H-ECT.

Single-phase/3-phase 200 VAC: R88D-1SAN15H-ECT (1.5 kW)
 3-phase 200 VAC: R88D-1SAN20H-ECT/-1SAN30H-ECT (2 to 3 kW)
 3-phase 400 VAC: R88D-1SAN10F-ECT/-1SAN15F-ECT/-1SAN20F-ECT/-1SAN30F-ECT (1 to 3 kW)

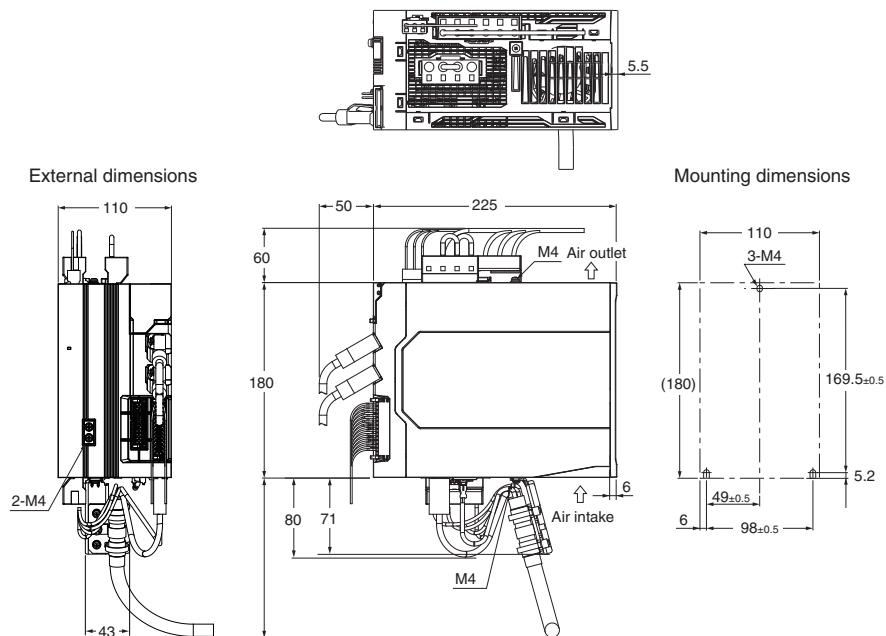

AC Servomotors [1S-series with Safety Functionality]

R88M-1AL□/□-1AM□

Contents

- Ordering Information
- Specifications
- Names and Functions
- External Dimensions

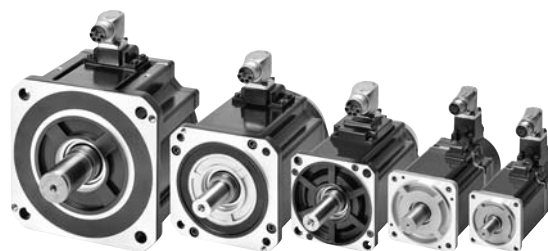

Ordering Information

Refer to the Ordering Information.

Specifications

General Specifications

Item		Specifications
Operating ambient temperature and humidity		0 to 40°C 20% to 90% (with no condensation)
Storage ambient temperature and humidity		-20 to 65°C 20% to 90% (with no condensation)
Operating and storage atmosphere		No corrosive gases
Vibration resistance *		Acceleration of 49 m/s ² 24.5 m/s ² max. in X, Y, and Z directions when the motor is stopped
Impact resistance		Acceleration of 98 m/s ² max. 3 times each in X, Y, and Z directions
Insulation resistance		Between power terminals and FG terminals: 10 MΩ min. (at 500 VDC Megger)
Dielectric strength		Between power terminals and FG terminals: 1,500 VAC for 1 min (voltage 200 V) Between power terminals and FG terminals: 1,800 VAC for 1 min (voltage 400 V) Between brake terminal and FG terminals: 1,000 VAC for 1 min
Insulation class		Class F
Protective structure		IP67 (except for the through-shaft part and connector pins)
International standard	EU Directives	EN 60034-1/-5
	Low Voltage Directive	
	UL standards	UL 1004-1/-6
	CSA standards	CSA C22.2 No.100 (with cUR mark)

* The amplitude may be increased by machine resonance. As a guideline, 80% of the specified value must not be exceeded.

Note: 1. Do not use the cable when it is laying in oil or water.

2. Do not expose the cable outlet or connections to stress due to bending or its own weight.

Encoder Specifications

Item	Specifications
Encoder system	Optical batteryless absolute encoder
Resolution per rotation	20 bits
Multi-rotation data hold	12 bits
Output signal	Serial communications
Output interface	RS485 compliant

Note: It is possible to use an absolute encoder as an incremental encoder.

Refer to the *AC Servomotors/Servo Drives 1S-series with Built-in EtherCAT® Communications and Safety Functionality User's Manual* (Cat.No.I621) for details.

AC Servo System 1S-series with Safety Functionality

Characteristics

3,000-r/min Servomotors

Item		Model (R88M-) Unit	200 VAC		
			1AM20030T	1AM40030T	1AM75030T
Rated output *1*2		W	200	400	750
Rated torque *1*2		N·m	0.637	1.27	2.39
Rated rotation speed *1*2		r/min	3000		
Maximum rotation speed		r/min	6000		
Momentary maximum torque *1*3		N·m	2.2 *4	4.5 *4	8.4 *4
Rated current *1*2		A(rms)	1.5	2.5	4.6
Momentary maximum current *1		A(rms)	5.6	9.1	16.9
Rotor inertia	Without brake	$\times 10^{-4}$ kg·m ²	0.224	0.446	1.825
	With brake	$\times 10^{-4}$ kg·m ²	0.284	0.506	2.075
Applicable load inertia		$\times 10^{-4}$ kg·m ²	4.80	8.40	19.4
Torque constant *1		N·m/A(rms)	0.48	0.56	0.59
Power rate *1*5		kW/s	18.1	36.2	31.3
Mechanical time constant *5		ms	0.79	0.58	0.66
Electrical time constant		ms	2.4	2.6	3.3
Allowable radial load *6		N	245	245	490
Allowable thrust load *6		N	88	88	196
Weight	Without brake	kg	1.3	1.8	3.2
	With brake	kg	1.7	2.2	4.1
Radiator plate dimensions (material)		mm	250 × 250 × t6 (aluminum)		
Brake specifications *7	Excitation voltage *8	V	24 DC $\pm 10\%$		
	Current consumption (at 20°C)	A	0.32	0.32	0.37
	Static friction torque	N·m	1.37 min.	1.37 min.	2.55 min.
	Attraction time	ms	30 max.	30 max.	40 max.
	Release time *9	ms	20 max.	20 max.	35 max.
	Backlash	°	1.2 max.	1.2 max.	1.0 max.
	Allowable braking work	J	60	60	250
	Allowable total work	J	60,000	60,000	250,000
	Allowable angular acceleration	rad/s ²	10,000 max.		
	Brake lifetime (acceleration/ deceleration)	---	10 million times min.		
	Brake lifetime (ON/OFF), B10d	---	1 million times min.		
	Insulation class	---	Class F		

For models with an oil seal the following derating is used due to increase in friction torque.

Item	Model (R88M-) Unit	1AM20030T-O/ -OS2/-BO/-BOS2	1AM40030T-O/ -OS2/-BO/-BOS2	1AM75030T-O/ -OS2/-BO/-BOS2
		Derating rate	%	95
Rated output	W	190	320	675
Rated current	A (rms)	1.5	2.1	4.2

AC Servo System 1S-series with Safety Functionality

Item		Model (R88M-)	200 VAC			
			1AL1K030T	1AL1K530T	1AL2K030T	1AL2K630T
Rated output *1*2		W	1,000	1,500	2,000	2,600
Rated torque *1*2		N·m	3.18	4.77	6.37	8.28
Rated rotation speed *1*2		r/min	3,000			
Maximum rotation speed		r/min	5,000			
Momentary maximum torque *1*3		N·m	9.55	14.3	19.1	24.8
Rated current *1*2		A(rms)	5.2	8.8	12.5	14.8
Momentary maximum current *1		A(rms)	16.9	28.4	41.0	47.3
Rotor inertia	Without brake	$\times 10^{-4}$ kg·m ²	2.105	2.105	2.405	6.813
	With brake	$\times 10^{-4}$ kg·m ²	2.555	2.555	2.855	7.313
Applicable load inertia		$\times 10^{-4}$ kg·m ²	35.3	47.6	60.2	118
Torque constant *1		N·m/A(rms)	0.67	0.58	0.56	0.62
Power rate *1*5		kW/s	48	108	169	101
Mechanical time constant *5		ms	0.58	0.58	0.50	0.47
Electrical time constant		ms	5.9	6.1	6.4	11
Allowable radial load *6		N	490			
Allowable thrust load *6		N	196			
Weight	Without brake	kg	5.8	5.8	6.5	11.5
	With brake	kg	7.5	7.5	8.2	13.5
Radiator plate dimensions (material)		mm	400 × 400 × t20 (aluminum)		470 × 470 × t20 (aluminum)	
Brake specifications *7	Excitation voltage *8	V	24 VDC \pm 10%			
	Current consumption (at 20°C)	A	0.70	0.70	0.70	0.66
	Static friction torque	N·m	9.3 min.	9.3 min.	9.3 min.	12 min.
	Attraction time	ms	100 max.	100 max.	100 max.	100 max.
	Release time *9	ms	30 max.	30 max.	30 max.	30 max.
	Backlash	°	1.0 max.	1.0 max.	1.0 max.	0.8 max.
	Allowable braking work	J	500	500	500	1000
	Allowable total work	J	900,000	900,000	900,000	3000,000
	Allowable angular acceleration	rad/s ²	10,000 max.			
	Brake lifetime (acceleration/ deceleration)	---	10 million times min.			
	Brake lifetime (ON/OFF), B10d	---	1 million times min.			
	Insulation class	---	Class F			

AC Servo System 1S-series with Safety Functionality

Item		Model (R88M-) Unit	AC400V		
			1AL75030C	1AL1K030C	1AL1K530C
Rated output *1*2		W	750	1,000	1,500
Rated torque *1*2		N·m	2.39	3.18	4.77
Rated rotation speed *1*2		r/min	3,000		
Maximum rotation speed		r/min	5,000		
Momentary maximum torque *1*3		N·m	7.16	9.55	14.3
Rated current *1*2		A(rms)	3.0	3.0	4.5
Momentary maximum current *1		A(rms)	9.6	9.6	14.1
Rotor inertia	Without brake	$\times 10^{-4}$ kg·m ²	1.305	2.105	2.105
	With brake	$\times 10^{-4}$ kg·m ²	1.755	2.555	2.555
Applicable load inertia		$\times 10^{-4}$ kg·m ²	38.6	35.3	47.6
Torque constant *1		N·m/A(rms)	0.91	1.17	1.17
Power rate *1*5		kW/s	44	48	108
Mechanical time constant *5		ms	1.1	0.58	0.58
Electrical time constant		ms	4.3	5.9	5.9
Allowable radial load *6		N	490		
Allowable thrust load *6		N	196		
Weight	Without brake	kg	4.2	5.8	5.8
	With brake	kg	5.9	7.5	7.5
Radiator plate dimensions (material)		mm	305 × 305 × t20 (aluminum)	400 × 400 × t20 (aluminum)	
Brake specifications *7	Excitation voltage *8	V	24 VDC \pm 10%		
	Current consumption (at 20°C)	A	0.70	0.70	0.70
	Static friction torque	N·m	9.3 min.	9.3 min.	9.3 min.
	Attraction time	ms	100 max.	100 max.	100 max.
	Release time *9	ms	30 max.	30 max.	30 max.
	Backlash	°	1.0 max.	1.0 max.	1.0 max.
	Allowable braking work	J	500	500	500
	Allowable total work	J	900,000	900,000	900,000
	Allowable angular acceleration	rad/s ²	10,000 max.		
	Brake lifetime (acceleration/ deceleration)	---	10 million times min.		
	Brake lifetime (ON/OFF), B10d	---	1 million times min.		
	Insulation class	---	Class F		

AC Servo System 1S-series with Safety Functionality

Item		Model (R88M-)	AC400V	
			1AL2K030C	1AL3K030C
Rated output *1*2		W	2,000	3,000
Rated torque *1*2		N·m	6.37	9.55
Rated rotation speed *1*2		r/min	3,000	
Maximum rotation speed		r/min	5,000	
Momentary maximum torque *1*3		N·m	19.1	28.7
Rated current *1*2		A(rms)	6.3	8.7
Momentary maximum current *1		A(rms)	19.8	27.7
Rotor inertia	Without brake	$\times 10^{-4}$ kg·m ²	2.405	6.813
	With brake	$\times 10^{-4}$ kg·m ²	2.855	7.313
Applicable load inertia		$\times 10^{-4}$ kg·m ²	60.2	118
Torque constant *1		N·m/A(rms)	1.15	1.23
Power rate *1*5		kW/s	169	134
Mechanical time constant *5		ms	0.52	0.49
Electrical time constant		ms	6.3	11
Allowable radial load *6		N	490	
Allowable thrust load *6		N	196	
Weight	Without brake	kg	6.5	11.5
	With brake	kg	8.2	13.5
Radiator plate dimensions (material)		mm	470 × 470 × t20 (aluminum)	
Brake specifications *7	Excitation voltage *8	V	24 VDC \pm 10%	
	Current consumption (at 20°C)	A	0.70	0.66
	Static friction torque	N·m	9.3 min.	12 min.
	Attraction time	ms	100 max.	100 max.
	Release time *9	ms	30 max.	30 max.
	Backlash	°	1.0 max.	0.8 max.
	Allowable braking work	J	500	1,000
	Allowable total work	J	900,000	3,000,000
	Allowable angular acceleration	rad/s ²	10,000 max.	
	Brake lifetime (acceleration/ deceleration)	---	10 million times min.	
	Brake lifetime (ON/OFF), B10d	---	1 million times min.	
	Insulation class	---	Class F	

*1. This is a typical value for when the Servomotor is used at a normal temperature (20°C, 65%) in combination with a Servo Drive.

*2. The rated values are the values with which continuous operation is possible at an ambient temperature of 40°C when the Servomotor is horizontally installed on a specified radiator plate.

*3. The momentary maximum torque is approximately 300% of the rated torque, except for some models.

*4. The momentary maximum torque is approximately 350% of the rated torque. Output at the momentary maximum torque shortens detection time of the overload protection function. Refer to Electronic Thermal Function in the *AC Servomotors/Servo Drives 1S-series with Built-in EtherCAT® Communications and Safety Functionality User's Manual* (Cat. No. I621) for details.

*5. This value is for models without options.

*6. The allowable radial and thrust loads are the values determined for a limit of 20,000 hours at normal operating temperatures. The allowable radial loads are applied as shown in the following diagram.

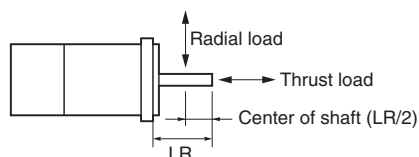

*7. When the brake is released for a vertical axis, refer to the *AC Servomotors/Servo Drives 1S-series with Built-in EtherCAT® Communications and Safety Functionality User's Manual* (Cat. No. I621) to set an appropriate value for Brake Interlock Output (4610 hex).

*8. This is a non-excitation brake. It is released when excitation voltage is applied.

*9. This value is a reference value.

Torque-Rotation Speed Characteristics for 3,000-r/min Servomotors (200 VAC)

The following graphs show the characteristics with a 3-m standard cable and a 3-phase 200-VAC or single-phase 220-VAC input.

· R88M-1AM20030T

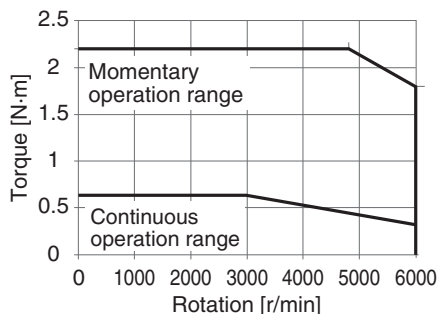

· R88M-1AM40030T

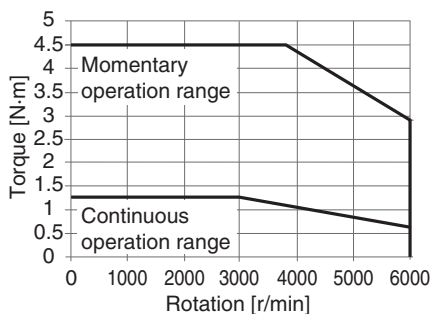

· R88M-1AM75030T

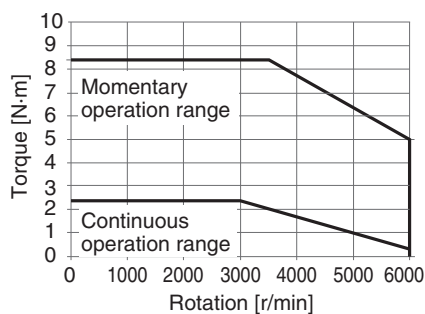

· R88M-1AL1K030T

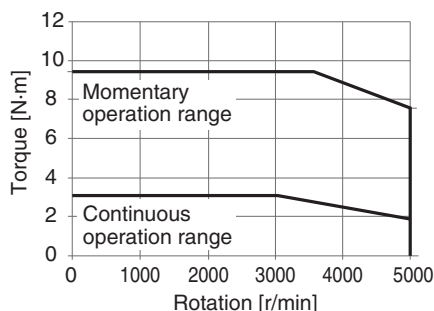

· R88M-1AL1K530T

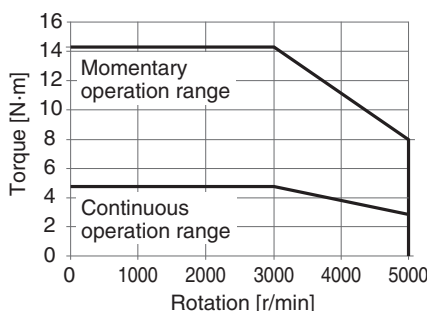

· R88M-1AL2K030T

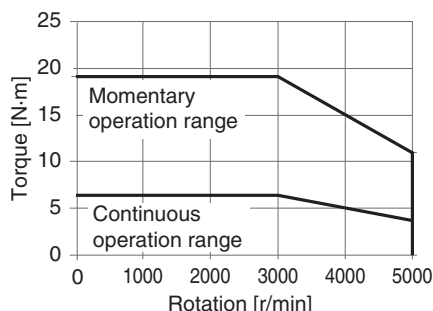

· R88M-1AL2K630T

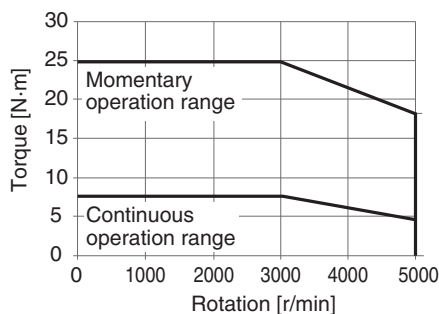

Note: The continuous operation range is the range in which continuous operation is possible at an ambient temperature of 40°C when the Servomotor is horizontally installed on a specified radiator plate. Continuous operation at the maximum speed is also possible. However, doing so will reduce the output torque.

AC Servo System 1S-series with Safety Functionality

Torque-Rotation Speed Characteristics for 3,000-r/min Servomotors (400 VAC)

The following graphs show the characteristics with a 3-m standard cable and a 3-phase 400-VAC input.

· R88M-1AL75030C

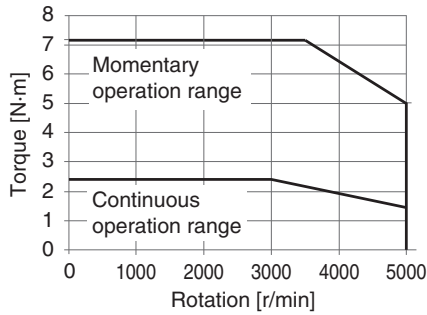

· R88M-1AL1K030C

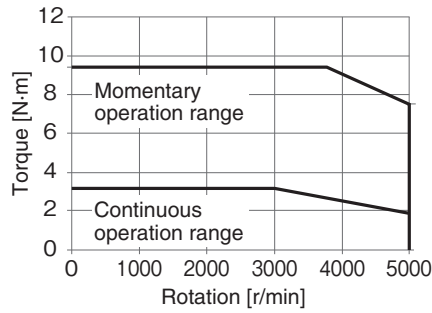

· R88M-1AL1K530C

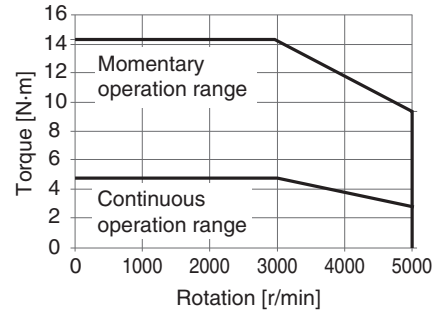

· R88M-1AL2K030C

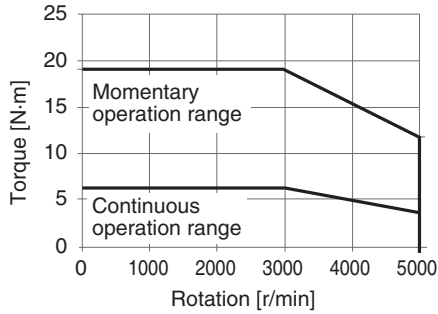

· R88M-1AL3K030C

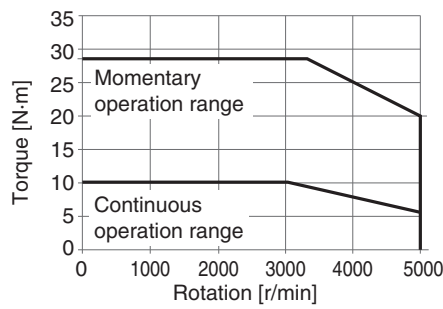

Note: The continuous operation range is the range in which continuous operation is possible at an ambient temperature of 40°C when the Servomotor is horizontally installed on a specified radiator plate. Continuous operation at the maximum speed is also possible. However, doing so will reduce the output torque.

AC Servo System 1S-series with Safety Functionality

1,500-r/min Servomotors

Item		Model (R88M-) Unit	AC200V	
			1AM1K515T	1AM2K715T
Rated output *1*2		W	1,500	2,700
Rated torque *1*2		N·m	9.55	17.2
Rated rotation speed *1*2		r/min	1,500	
Maximum rotation speed		r/min	3,000	
Momentary maximum torque *1		N·m	28.7	51.6
Rated current *1*2		A(rms)	8.6	14.6
Momentary maximum current *1		A(rms)	28.4	49.3
Rotor inertia	Without brake	$\times 10^{-4}$ kg·m ²	12.413	40.013
	With brake	$\times 10^{-4}$ kg·m ²	13.013	45.113
Applicable load inertia		$\times 10^{-4}$ kg·m ²	127.05	270.63
Torque constant *1		N·m/A(rms)	1.11	1.29
Power rate *1*3		kW/s	73	74
Mechanical time constant *3		ms	0.75	1.0
Electrical time constant		ms	17	19
Allowable radial load *4		N	490	1176
Allowable thrust load *4		N	196	490
Weight	Without brake	kg	11	18
	With brake	kg	13	22
Radiator plate dimensions (material)		mm	470 × 470 × t20 (aluminum)	
Brake specifications *5	Excitation voltage *6	V	24 VDC \pm 10%	
	Current consumption (at 20°C)	A	0.66	1.20
	Static friction torque	N·m	12 min.	22 min.
	Attraction time	ms	100 max.	120 max.
	Release time *7	ms	30 max.	50 max.
	Backlash	°	0.6 max.	0.8 max.
	Allowable braking work	J	1,000	1,400
	Allowable total work	J	3,000,000	4,600,000
	Allowable angular acceleration	rad/s ²	10,000 max.	
	Brake lifetime (acceleration/ deceleration)	---	10 million times min.	
	Brake lifetime (ON/OFF), B10d	---	1 million times min.	
	Insulation class	---	Class F	

AC Servo System 1S-series with Safety Functionality

Item		Model (R88M-)	AC400V	
			1AM1K515C	1AM3K015C
Rated output *1*2		W	1,500	3,000
Rated torque *1*2		N·m	9.55	19.1
Rated rotation speed *1*2		r/min	1,500	
Maximum rotation speed		r/min	3,000	
Momentary maximum torque *1		N·m	28.7	57.3
Rated current *1*2		A(rms)	4.4	8.5
Momentary maximum current *1		A(rms)	14.1	28.3
Rotor inertia	Without brake	$\times 10^{-4}$ kg·m ²	12.413	40.013
	With brake	$\times 10^{-4}$ kg·m ²	13.013	45.113
Applicable load inertia		$\times 10^{-4}$ kg·m ²	127.05	270.63
Torque constant *1		N·m/A(rms)	2.21	2.46
Power rate *1*3		kW/s	73	91
Mechanical time constant *3		ms	0.75	1.2
Electrical time constant		ms	17	16
Allowable radial load *4		N	490	1176
Allowable thrust load *4		N	196	490
Weight	Without brake	kg	11	18
	With brake	kg	13	22
Radiator plate dimensions (material)		mm	470 × 470 × t20 (aluminum)	
Brake specifications *5	Excitation voltage *6	V	24 VDC \pm 10%	
	Current consumption (at 20°C)	A	0.66	1.20
	Static friction torque	N·m	12 min.	22 min.
	Attraction time	ms	100 max.	120 max.
	Release time *7	ms	30 max.	50 max.
	Backlash	°	0.6 max.	0.8 max.
	Allowable braking work	J	1,000	1,400
	Allowable total work	J	3,000,000	4,600,000
	Allowable angular acceleration	rad/s ²	10,000 max.	
	Brake lifetime (acceleration/ deceleration)	---	10 million times min.	
	Brake lifetime (ON/OFF), B10d	---	1 million times min.	
	Insulation class	---	Class F	

*1. This is a typical value for when the Servomotor is used at a normal temperature (20°C, 65%) in combination with a Servo Drive.

*2. The rated values are the values with which continuous operation is possible at an ambient temperature of 40°C when the Servomotor is horizontally installed on a specified radiator plate.

*3. This value is for models without options.

*4. The allowable radial and thrust loads are the values determined for a limit of 20,000 hours at normal operating temperatures. The allowable radial loads are applied as shown in the following diagram.

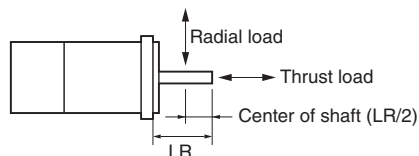

*5. When the brake is released for a vertical axis, refer to the *AC Servomotors/Servo Drives 1S-series with Built-in EtherCAT® Communications and Safety Functionality User's Manual* (Cat. No. I621) to set an appropriate value for Brake Interlock Output (4610 hex).

*6. This is a non-excitation brake. It is released when excitation voltage is applied.

*7. This value is a reference value.

Torque-Rotation Speed Characteristics for 1,500-r/min Servomotors (200 VAC)

The following graphs show the characteristics with a 3-m standard cable and a 3-phase 200-VAC or single-phase 220-VAC input.

· R88M-1AM1K515T

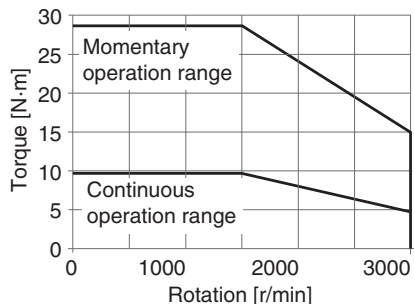

· R88M-1AM2K715T

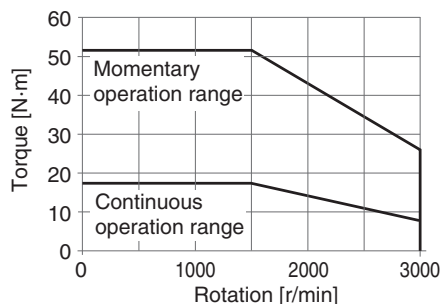

Note: The continuous operation range is the range in which continuous operation is possible at an ambient temperature of 40°C when the Servomotor is horizontally installed on a specified radiator plate. Continuous operation at the maximum speed is also possible. However, doing so will reduce the output torque.

Torque-Rotation Speed Characteristics for 1,500-r/min Servomotors (400 VAC)

The following graphs show the characteristics with a 3-m standard cable and a 3-phase 400-VAC input.

· R88M-1AM1K515C

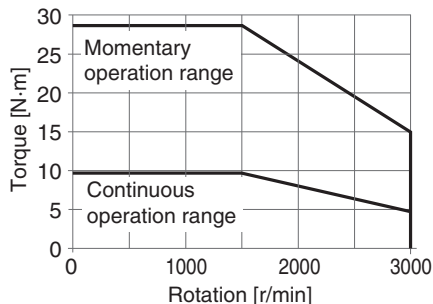

· R88M-1AM3K015C

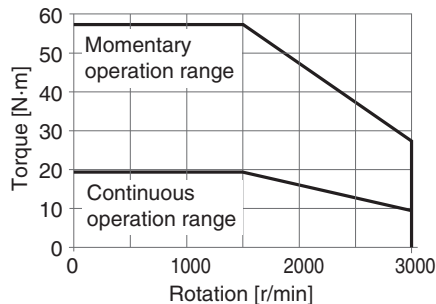

Note: The continuous operation range is the range in which continuous operation is possible at an ambient temperature of 40°C when the Servomotor is horizontally installed on a specified radiator plate. Continuous operation at the maximum speed is also possible. However, doing so will reduce the output torque.

AC Servo System 1S-series with Safety Functionality

Part Names

Servomotor Part Names

Flange Size of 60×60, 80×80

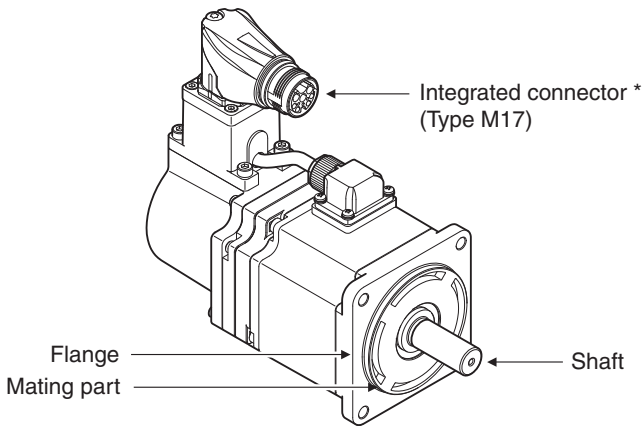

* For servomotors without Brake, brake wire signals are not use (terminal open).

200 VAC 200 W Servomotors (without Brake)

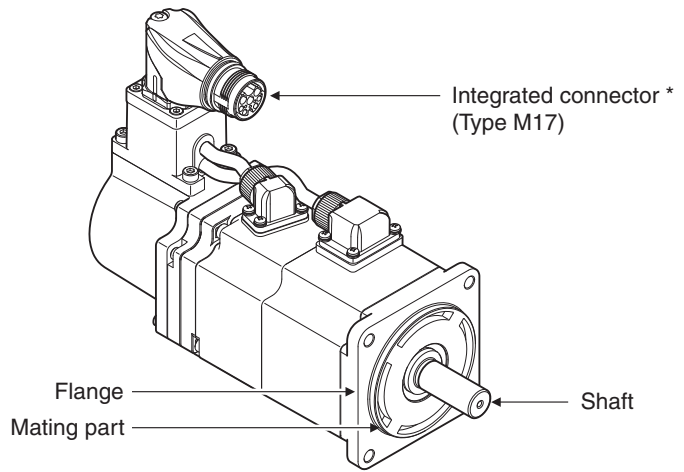

200 VAC 200 W Servomotors (with Brake)

Flange Size of 100×100, 130×130, 180×180

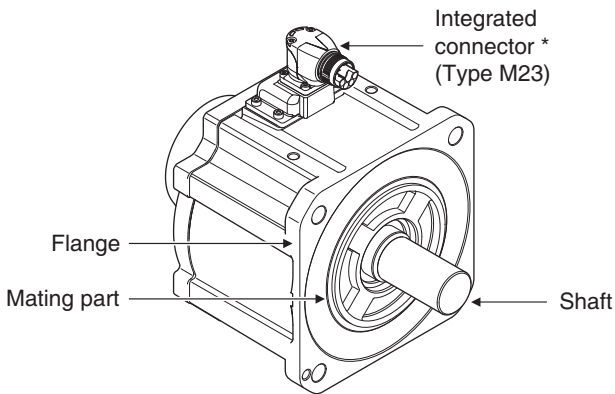

* For servomotors without Brake, brake wire signals are not use (terminal open).

400 VAC 3 kW Servomotors (without Brake)

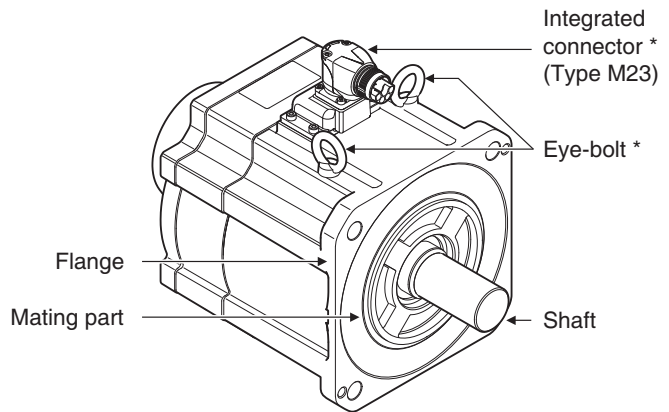

* In some cases, eye bolts are not equipped, depending on the Servomotor's mass.

400 VAC 3 kW Servomotors (with Brake)

Servomotor Functions

Shaft

The load is mounted on this shaft.

The direction which is in parallel with the shaft is called the thrust direction, and the direction which is perpendicular to the shaft is called the radial direction.

Flange

Used for mounting the Servomotor on the equipment.

Fit the mating part into the equipment and use the mounting holes to screw the Servomotor.

Integrated Connector

This is an integrated connector that can connect each cable for power, encoder and brake all at once.

The power cable supplies power to the phases U, V, and W of the Servomotor.

The encoder cable supplies power to the encoder of the Servomotor and communicates with the Servo Drive.

The brake cable supplies power to the brake coil.

The cable outlet direction can be selected. The change of the cable outlet direction shall be up to five times.

Eye-bolt

Used for lifting and moving the motor by putting a wire rope, for example, through the shaft.

External Dimensions

(Unit: mm)

3,000-r/min Servomotors (200 V)

200 W/400 W (without Brake)

R88M-1AM20030T(-O/-S2/-OS2), R88M-1AM40030T(-O/-S2/-OS2)

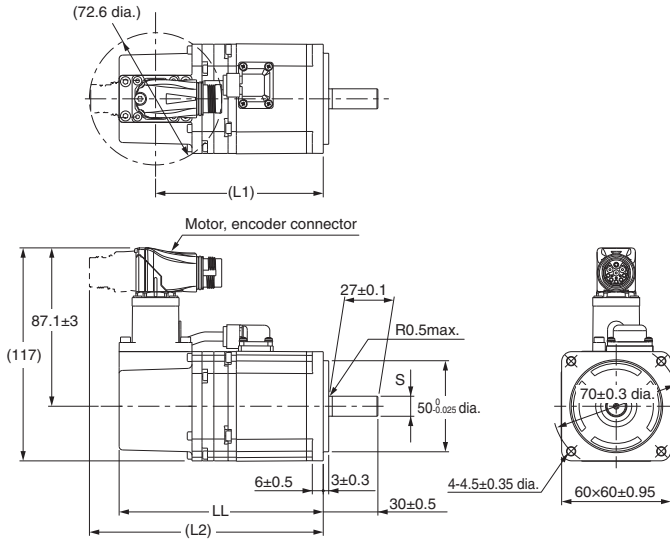

Shaft-end with key and tap

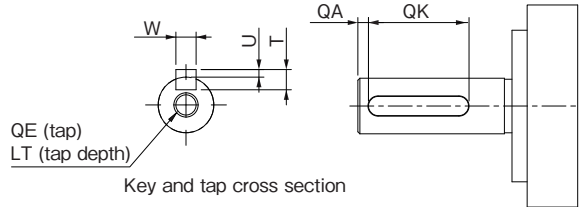

Model	Dimensions [mm]			
	S	LL	L1	L2
R88M-1AM20030T(-S2)	11 dia. $^{0}_{-0.011}$	112±1	92	128
R88M-1AM40030T(-S2)	14 dia. $^{0}_{-0.011}$	138±1	118	154
R88M-1AM20030T(-O(S2))	11 dia. $^{0}_{-0.011}$	119±1	99	135
R88M-1AM40030T(-O(S2))	14 dia. $^{0}_{-0.011}$	145±1	125	161

Model	Dimensions [mm]						
	QA	QK	W	T	U	QE	LT
R88M-1AM20030T(-S2/-OS2)	2	20	4 $^{0}_{-0.03}$	4	1.5 $^{0}_{-0.2}$	M4	10
R88M-1AM40030T(-S2/-OS2)	2	20	5 $^{0}_{-0.03}$	5	2 $^{0}_{-0.2}$	M5	12

Note: The standard shaft type is a straight shaft. Models with a key and tap are indicated with “S2” at the end of the model number. Models with an oil seal are indicated with “O” at the end of the model number.

200 W/400 W (with Brake)

R88M-1AM20030T-B(O/S2/OS2), R88M-1AM40030T-B(O/S2/OS2)

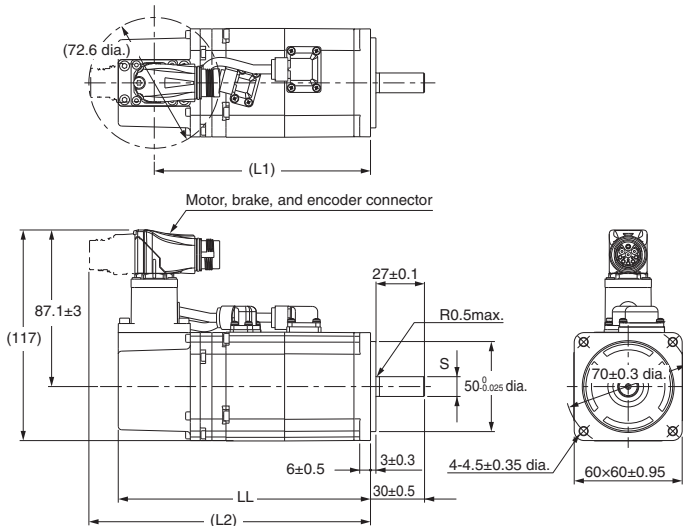

Shaft-end with key and tap

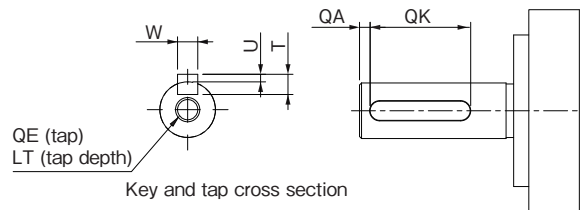

Model	Dimensions [mm]			
	S	LL	L1	L2
R88M-1AM20030T-B(S2)	11 dia. $^{0}_{-0.011}$	140±1	120	156
R88M-1AM40030T-B(S2)	14 dia. $^{0}_{-0.011}$	166±1	146	182
R88M-1AM20030T-B(O(S2))	11 dia. $^{0}_{-0.011}$	147±1	127	163
R88M-1AM40030T-B(O(S2))	14 dia. $^{0}_{-0.011}$	173±1	153	189

Model	Dimensions [mm]						
	QA	QK	W	T	U	QE	LT
R88M-1AM20030T-B(S2/OS2)	2	20	4 $^{0}_{-0.03}$	4	1.5 $^{0}_{-0.2}$	M4	10
R88M-1AM40030T-B(S2/OS2)	2	20	5 $^{0}_{-0.03}$	5	2 $^{0}_{-0.2}$	M5	12

Note: The standard shaft type is a straight shaft. Models with a key and tap are indicated with “S2” at the end of the model number. Models with an oil seal are indicated with “O” at the end of the model number.

AC Servo System 1S-series with Safety Functionality

750 W (without Brake)

R88M-1AM75030T(-O/-S2/-OS2)

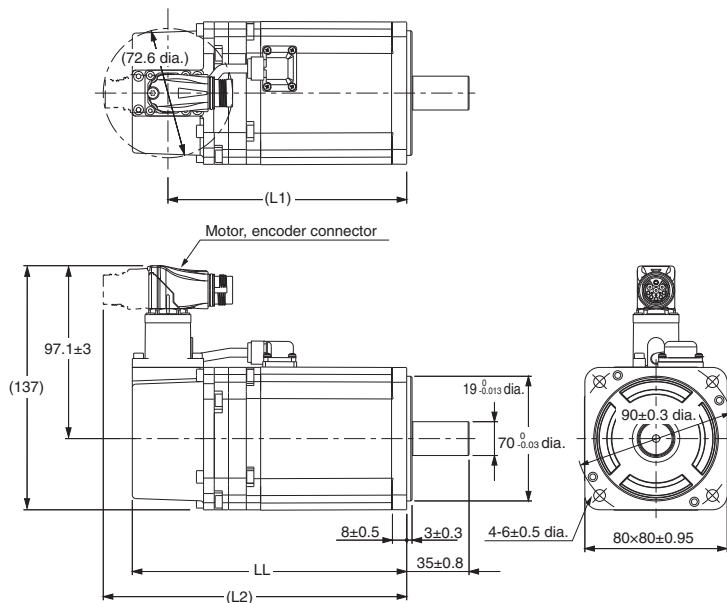

Shaft-end with key and tap

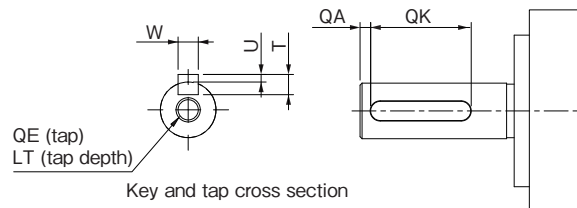

Model	Dimensions [mm]		
	LL	L1	L2
R88M-1AM75030T(-S2)	154±1	134	170
R88M-1AM75030T-O(S2)	161±1	141	177

Model	Dimensions [mm]						
	QA	QK	W	T	U	QE	LT
R88M-1AM75030T(-S2/-OS2)	3	24	6 ⁰ / _{-0.03}	6	2.5 ⁰ / _{-0.2}	M5	12

Note: The standard shaft type is a straight shaft. Models with a key and tap are indicated with “S2” at the end of the model number. Models with an oil seal are indicated with “O” at the end of the model number.

750 W (with Brake)

R88M-1AM75030T-B(O/S2/OS2)

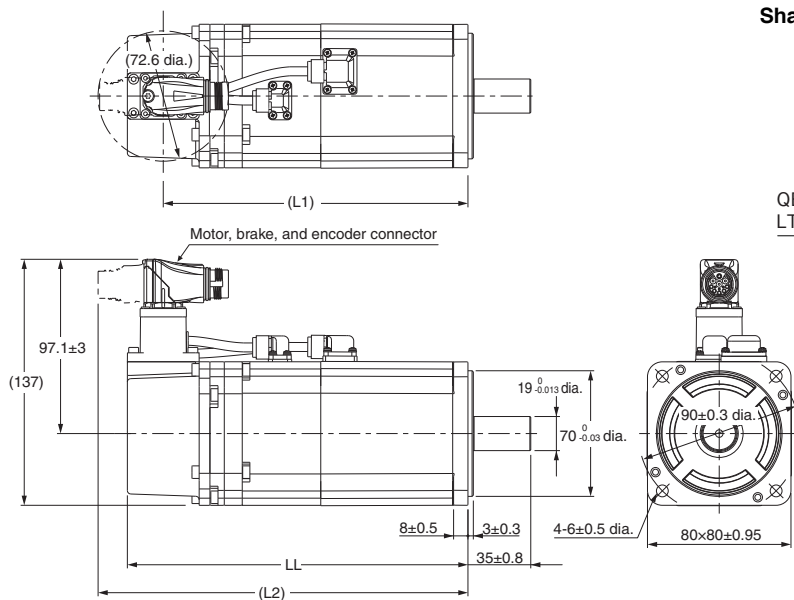

Shaft-end with key and tap

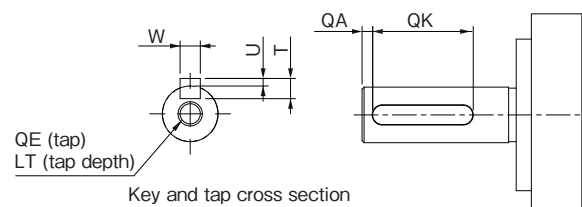

Model	Dimensions [mm]		
	LL	L1	L2
R88M-1AM75030T-B(S2)	189.8±2	170	206
R88M-1AM75030T-BO(S2)	196.8±2	177	213

Model	Dimensions [mm]						
	QA	QK	W	T	U	QE	LT
R88M-1AM75030T-B(S2/OS2)	3	24	6 ⁰ / _{-0.03}	6	2.5 ⁰ / _{-0.2}	M5	12

Note: The standard shaft type is a straight shaft. Models with a key and tap are indicated with “S2” at the end of the model number. Models with an oil seal are indicated with “O” at the end of the model number.

AC Servo System 1S-series with Safety Functionality

1 kW/1.5 kW/2 kW (without Brake)

R88M-1AL1K030T(-O/-S2/-OS2), R88M-1AL1K530T(-O/-S2/-OS2), R88M-1AL2K030T(-O/-S2/-OS2)

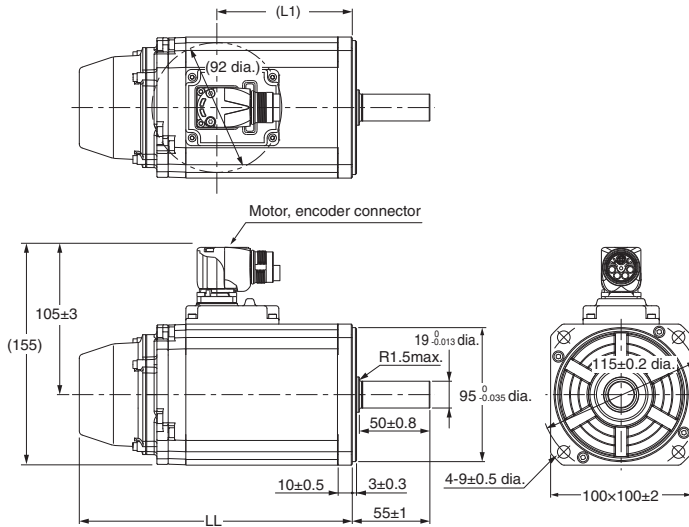

Shaft-end with key and tap

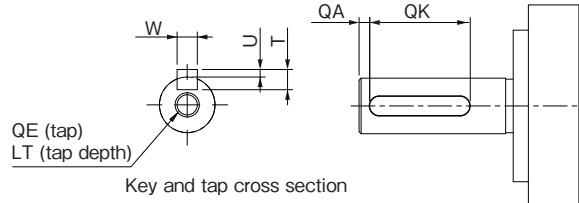

Model	Dimensions [mm]	
	LL	L1
R88M-1AL1K030T(-O/-S2/-OS2)	193.5±2	96
R88M-1AL1K530T(-O/-S2/-OS2)	193.5±2	96
R88M-1AL2K030T(-O/-S2/-OS2)	204.5±3	107

Model	Dimensions [mm]						
	QA	QK	W	T	U	QE	LT
R88M-1AL1K030T(-S2/-OS2)	3	42	6 ⁰ _{-0.03}	6	2.5 ⁰ _{-0.2}	M5	12
R88M-1AL1K530T(-S2/-OS2)	3	42	6 ⁰ _{-0.03}	6	2.5 ⁰ _{-0.2}	M5	12
R88M-1AL2K030T(-S2/-OS2)	3	42	6 ⁰ _{-0.03}	6	2.5 ⁰ _{-0.2}	M5	12

Note: The standard shaft type is a straight shaft. Models with a key and tap are indicated with "S2" at the end of the model number. Models with an oil seal are indicated with "O" at the end of the model number.

1 kW/1.5 kW/2 kW (with Brake)

R88M-1AL1K030T-B(O/S2/OS2), R88M-1AL1K530T-B(O/S2/OS2), R88M-1AL2K030T-B(O/S2/OS2)

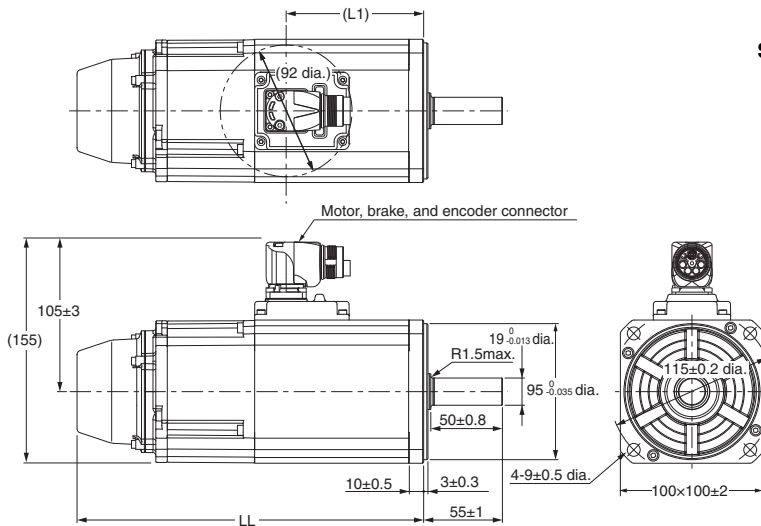

Shaft-end with key and tap

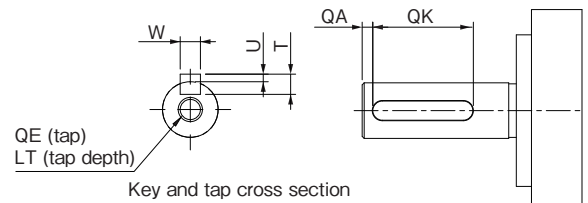

Model	Dimensions [mm]	
	LL	L1
R88M-1AL1K030T-B(O/S2/OS2)	242±3	96
R88M-1AL1K530T-B(O/S2/OS2)	242±3	96
R88M-1AL2K030T-B(O/S2/OS2)	253±3	107

Model	Dimensions [mm]						
	QA	QK	W	T	U	QE	LT
R88M-1AL1K030T-B(S2/OS2)	3	42	6 ⁰ _{-0.03}	6	2.5 ⁰ _{-0.2}	M5	12
R88M-1AL1K530T-B(S2/OS2)	3	42	6 ⁰ _{-0.03}	6	2.5 ⁰ _{-0.2}	M5	12
R88M-1AL2K030T-B(S2/OS2)	3	42	6 ⁰ _{-0.03}	6	2.5 ⁰ _{-0.2}	M5	12

Note: The standard shaft type is a straight shaft. Models with a key and tap are indicated with "S2" at the end of the model number. Models with an oil seal are indicated with "O" at the end of the model number.

AC Servo System 1S-series with Safety Functionality

2.6 kW (without Brake)

R88M-1AL2K630T(-O/-S2/-OS2)

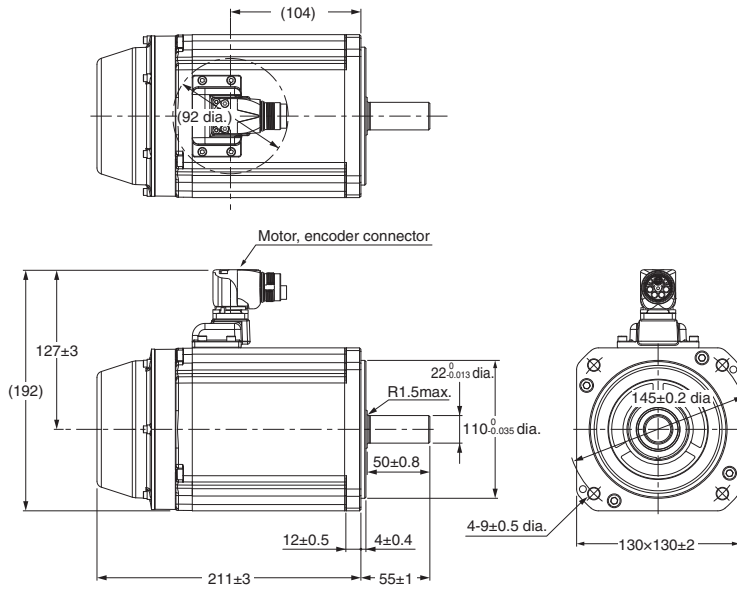

Shaft-end with key and tap

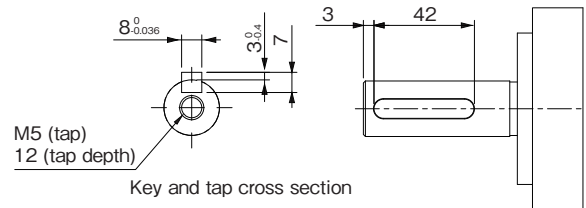

Note: The standard shaft type is a straight shaft. Models with a key and tap are indicated with "S2" at the end of the model number. Models with an oil seal are indicated with "O" at the end of the model number.

2.6 kW (with Brake)

R88M-1AL2K630T-B(O/S2/OS2)

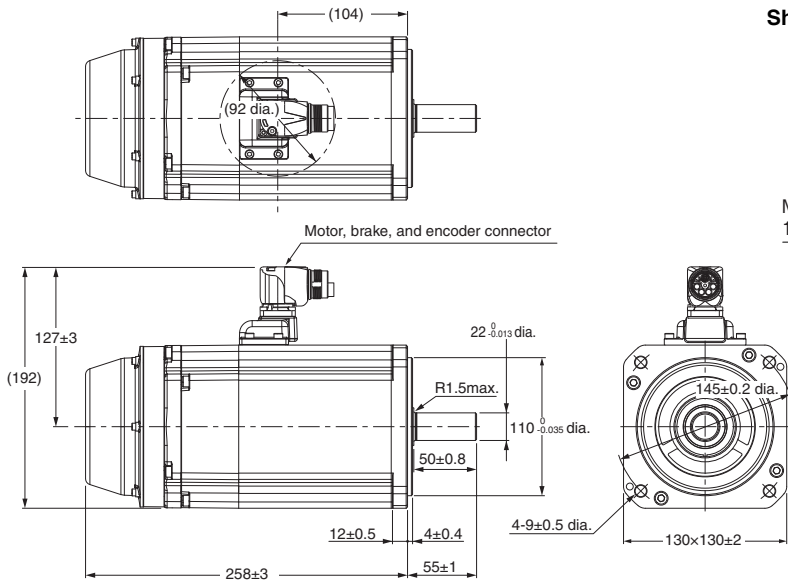

Shaft-end with key and tap

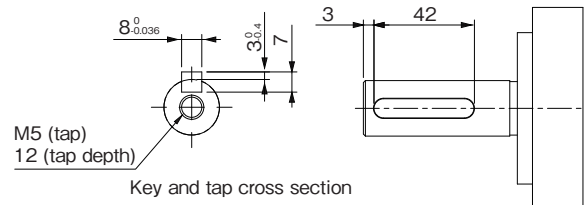

Note: The standard shaft type is a straight shaft. Models with a key and tap are indicated with "S2" at the end of the model number. Models with an oil seal are indicated with "O" at the end of the model number.

AC Servo System 1S-series with Safety Functionality

3,000-r/min Servomotors (400 V)

750 W/1 kW/1.5 kW/2 kW (without Brake)

R88M-1AL75030C(-O/-S2/-OS2), R88M-1AL1K030C(-O/-S2/-OS2)

R88M-1AL1K530C(-O/-S2/-OS2), R88M-1AL2K030C(-O/-S2/-OS2)

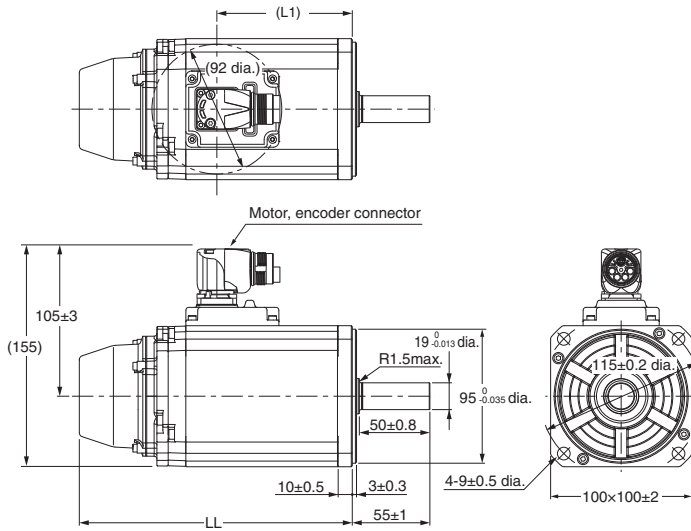

Shaft-end with key and tap

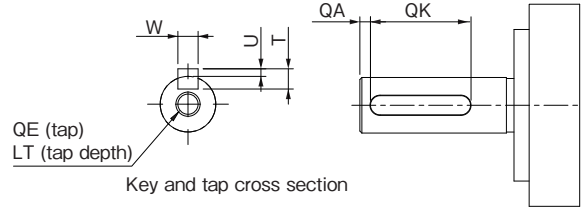

Model	Dimensions [mm]	
	LL	L1
R88M-1AL75030C(-O/-S2/-OS2)	164.5±2	67
R88M-1AL1K030C(-O/-S2/-OS2)	193.5±2	96
R88M-1AL1K530C(-O/-S2/-OS2)	193.5±2	96
R88M-1AL2K030C(-O/-S2/-OS2)	204.5±3	107

Model	Dimensions [mm]						
	QA	QK	W	T	U	QE	LT
R88M-1AL75030C(-S2/-OS2)	3	42	6 ⁰ _{-0.03}	6	2.5 ⁰ _{-0.2}	M5	12
R88M-1AL1K030C(-S2/-OS2)	3	42	6 ⁰ _{-0.03}	6	2.5 ⁰ _{-0.2}	M5	12
R88M-1AL1K530C(-S2/-OS2)	3	42	6 ⁰ _{-0.03}	6	2.5 ⁰ _{-0.2}	M5	12
R88M-1AL2K030C(-S2/-OS2)	3	42	6 ⁰ _{-0.03}	6	2.5 ⁰ _{-0.2}	M5	12

Note: The standard shaft type is a straight shaft. Models with a key and tap are indicated with "S2" at the end of the model number. Models with an oil seal are indicated with "O" at the end of the model number.

750 W/1 kW/1.5 kW/2 kW (with Brake)

R88M-1AL75030C-B(O/S2/OS2), R88M-1AL1K030C-B(O/S2/OS2)

R88M-1AL1K530C-B(O/S2/OS2), R88M-1AL2K030C-B(O/S2/OS2)

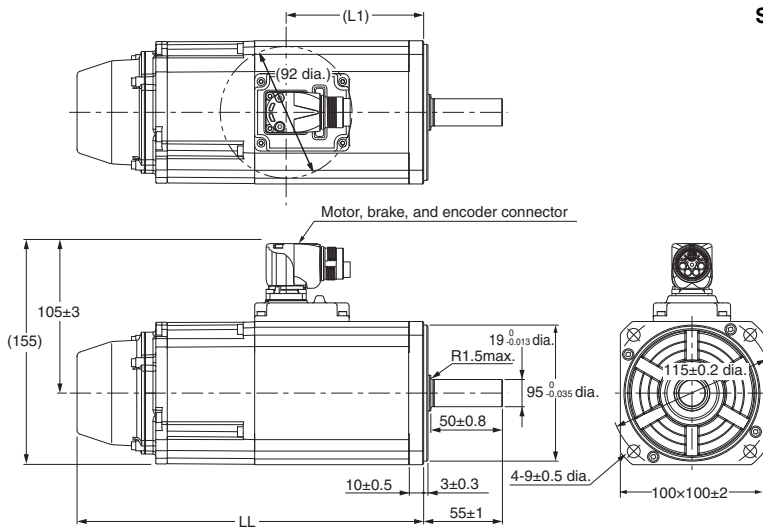

Shaft-end with key and tap

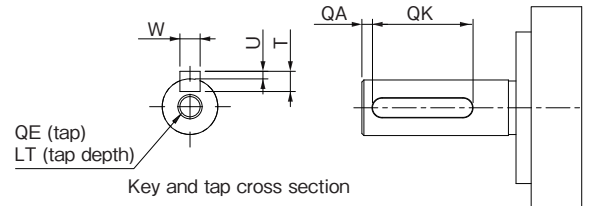

Model	Dimensions [mm]	
	LL	L1
R88M-1AL75030C-B(O/S2/OS2)	213±3	67
R88M-1AL1K030C-B(O/S2/OS2)	242±3	96
R88M-1AL1K530C-B(O/S2/OS2)	242±3	96
R88M-1AL2K030C-B(O/S2/OS2)	253±3	107

Model	Dimensions [mm]						
	QA	QK	W	T	U	QE	LT
R88M-1AL75030C-B(S2/OS2)	3	42	6 ⁰ _{-0.03}	6	2.5 ⁰ _{-0.2}	M5	12
R88M-1AL1K030C-B(S2/OS2)	3	42	6 ⁰ _{-0.03}	6	2.5 ⁰ _{-0.2}	M5	12
R88M-1AL1K530C-B(S2/OS2)	3	42	6 ⁰ _{-0.03}	6	2.5 ⁰ _{-0.2}	M5	12
R88M-1AL2K030C-B(S2/OS2)	3	42	6 ⁰ _{-0.03}	6	2.5 ⁰ _{-0.2}	M5	12

Note: The standard shaft type is a straight shaft. Models with a key and tap are indicated with "S2" at the end of the model number. Models with an oil seal are indicated with "O" at the end of the model number.

AC Servo System 1S-series with Safety Functionality

3 kW (without Brake)

R88M-1AL3K030C(-O/-S2/-OS2)

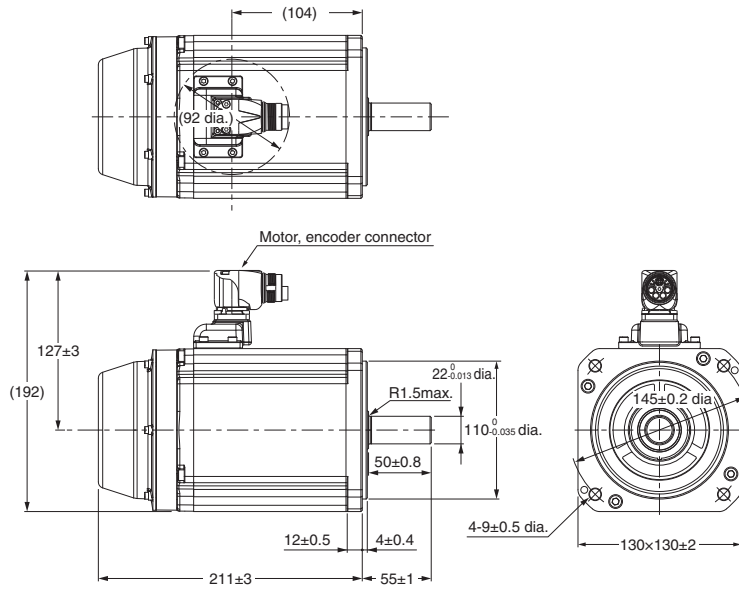

Shaft-end with key and tap

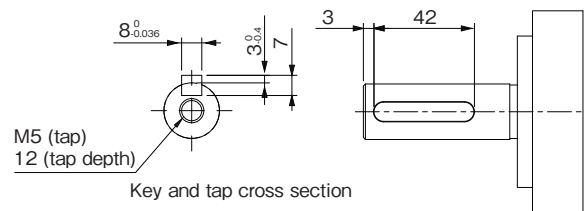

Note: The standard shaft type is a straight shaft. Models with a key and tap are indicated with "S2" at the end of the model number. Models with an oil seal are indicated with "O" at the end of the model number.

3 kW (with Brake)

R88M-1AL3K030C-B(O/S2/OS2)

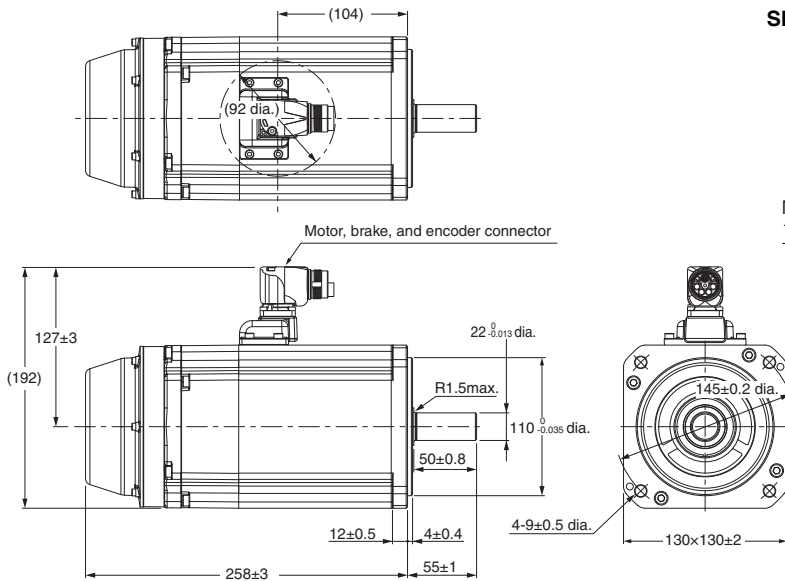

Shaft-end with key and tap

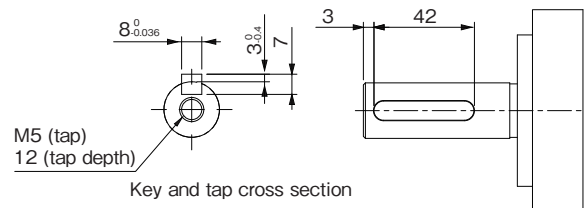

Note: The standard shaft type is a straight shaft. Models with a key and tap are indicated with "S2" at the end of the model number. Models with an oil seal are indicated with "O" at the end of the model number.

AC Servo System 1S-series with Safety Functionality

1,500-r/min Servomotors (200 V/400 V)

1.5 kW (without Brake)

R88M-1AM1K515T(-O/-S2/-OS2)

R88M-1AM1K515C(-O/-S2/-OS2)

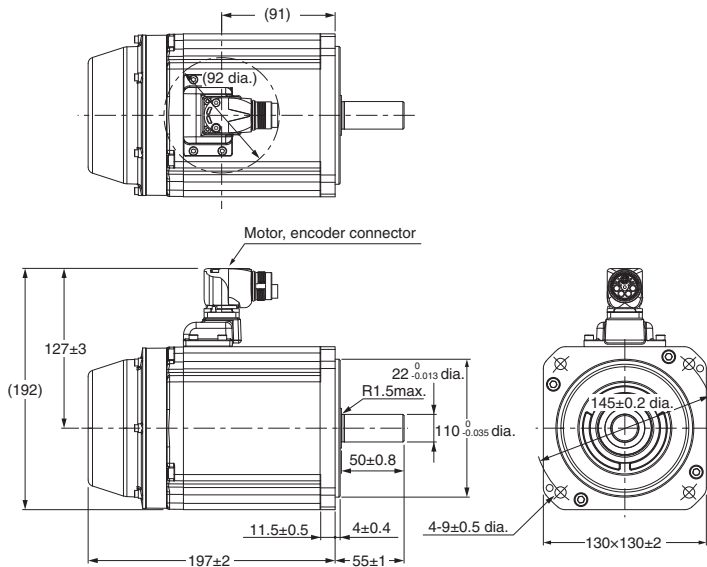

Shaft-end with key and tap

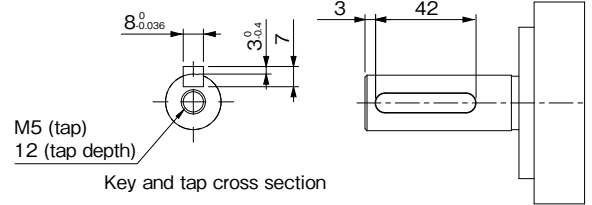

Note: The standard shaft type is a straight shaft. Models with a key and tap are indicated with "S2" at the end of the model number. Models with an oil seal are indicated with "O" at the end of the model number.

1.5 kW (with Brake)

R88M-1AM1K515T-B(O/S2/OS2)

R88M-1AM1K515C-B(O/S2/OS2)

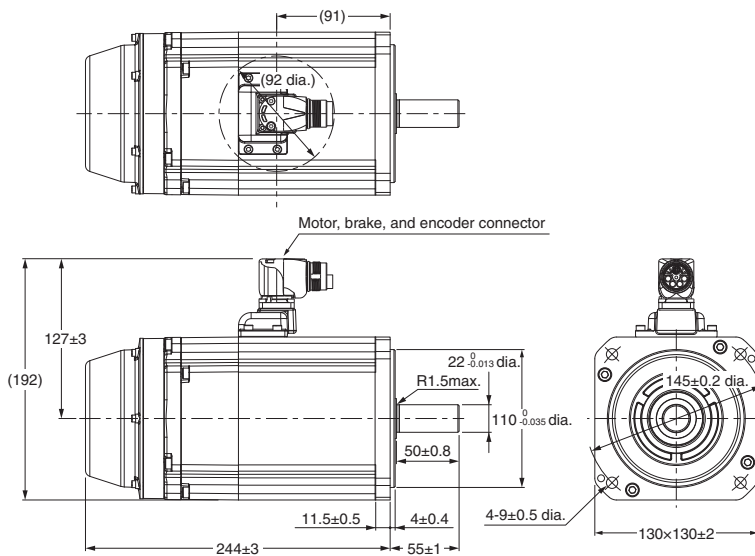

Shaft-end with key and tap

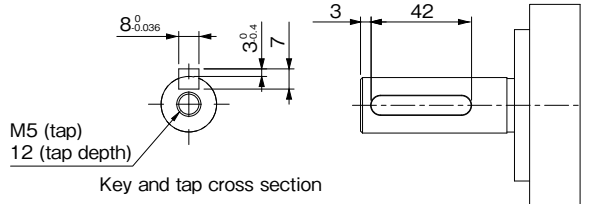

Note: The standard shaft type is a straight shaft. Models with a key and tap are indicated with "S2" at the end of the model number. Models with an oil seal are indicated with "O" at the end of the model number.

AC Servo System 1S-series with Safety Functionality

2.7 kW (without Brake) R88M-1AM2K715T(-O/-S2/-OS2)

3 kW (without Brake) R88M-1AM3K015C(-O/-S2/-OS2)

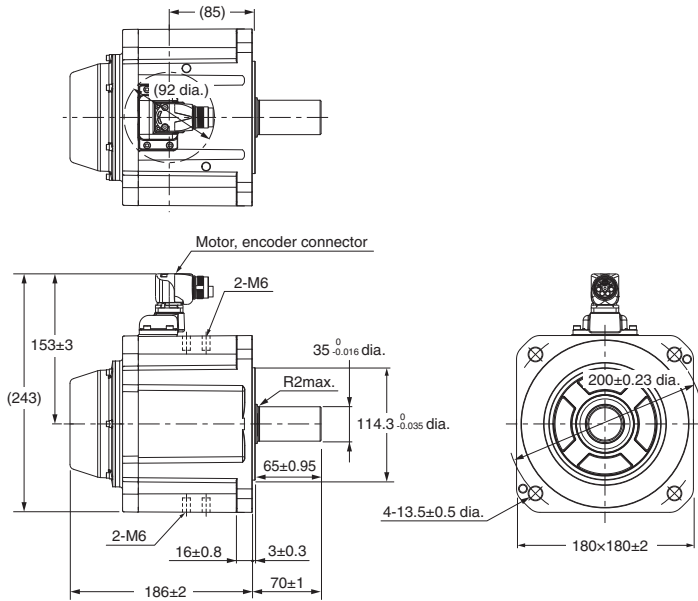

Shaft-end with key and tap

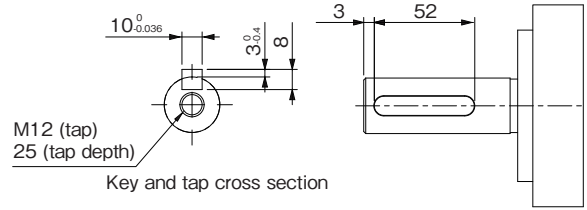

Note: The standard shaft type is a straight shaft. Models with a key and tap are indicated with "S2" at the end of the model number. Models with an oil seal are indicated with "O" at the end of the model number.

2.7 kW (with Brake) R88M-1AM2K715T-B(O/S2/OS2)

3 kW (with Brake) R88M-1AM3K015C-B(O/S2/OS2)

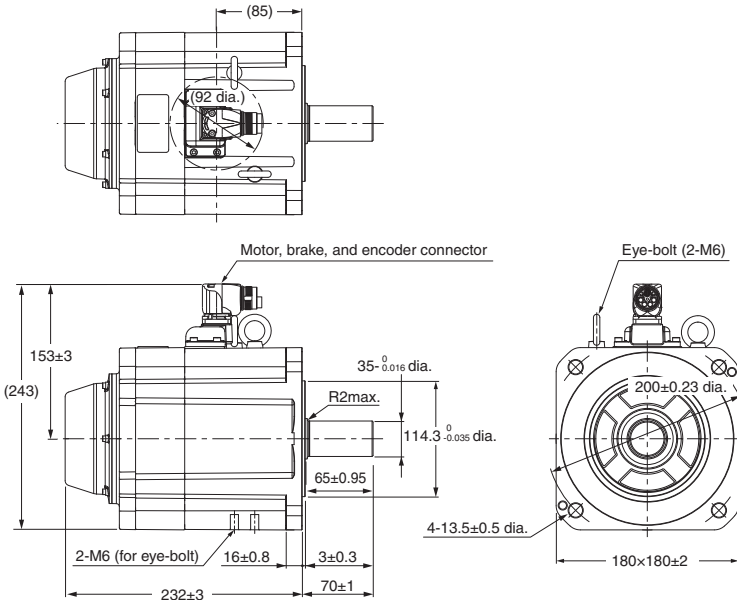

Shaft-end with key and tap

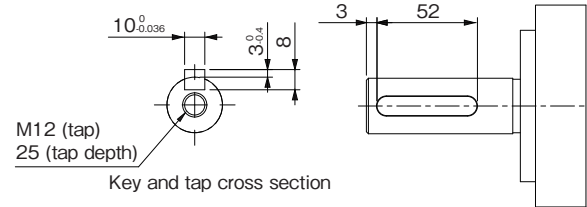

Note: The standard shaft type is a straight shaft. Models with a key and tap are indicated with "S2" at the end of the model number. Models with an oil seal are indicated with "O" at the end of the model number.

Cable Outlet Direction of Integrated Connector

The cable outlet direction of the servomotor for connector type M17 or M23 can be selected. The below shows the selectable range. The change of the cable outlet direction shall be up to five times. For a procedure of the change of the cable outlet direction, refer to the *AC Servomotors/Servo Drives 1S-series with Built-in EtherCAT® Communications and Safety Functionality User's Manual (I621)*.

Cable Outlet Direction of Connector Type M17

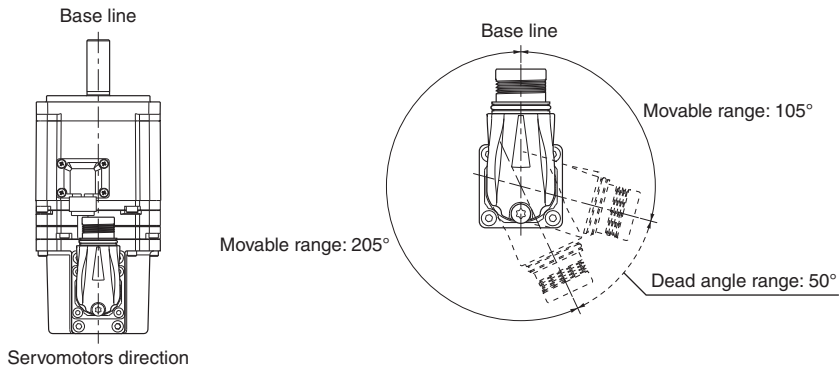

Cable Outlet Direction of Connector Type M23

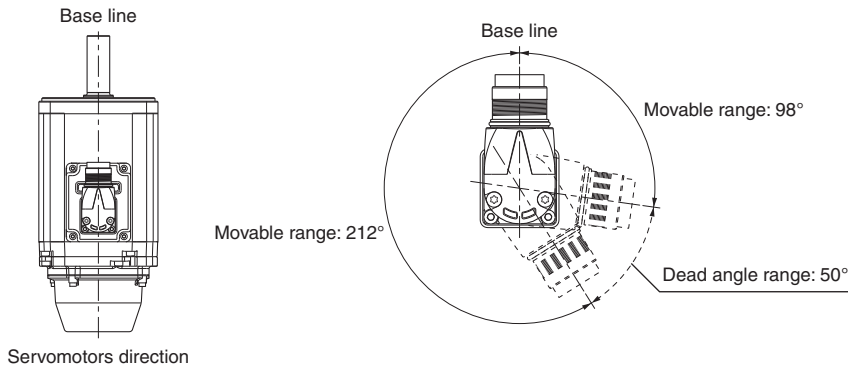

AC Servo System 1S-series with Safety Functionality

Cable Wiring Dimension for a Case of Servo Motor Installing

The Integrated cable wiring dimensions are shown below the table according to connector type for Servomotors.
The dimensions from the rotation center of the Integrated connector to the Integrated cable surrounding are indicated as A.

Servo Motor for Connector Type M17

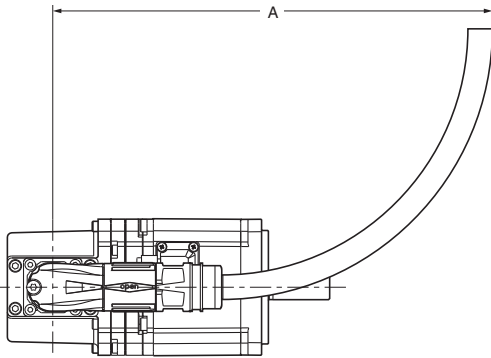

Model	Dimensions [mm]
	A
R88M-1AM20030T(-O/-S2/-OS2)	210
R88M-1AM40030T(-O/-S2/-OS2)	
R88M-1AM75030T(-O/-S2/-OS2)	
R88M-1AM20030T-B(O/S2/OS2)	
R88M-1AM40030T-B(O/S2/OS2)	
R88M-1AM75030T-B(O/S2/OS2)	

Servo Motor for Connector Type M23

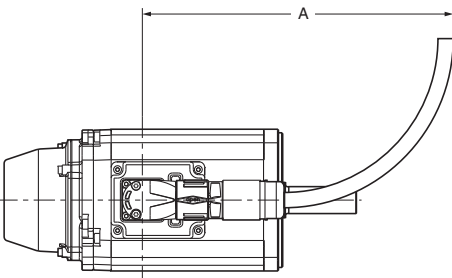

Model	Dimensions [mm]
	A
R88M-1AL75030C(-S2/-O/-OS2/-B/-BS2/-BO/-BOS2)	270
R88M-1AL1K030T(-S2/-O/-OS2/-B/-BS2/-BO/-BOS2)	
R88M-1AL1K030C(-S2/-O/-OS2/-B/-BS2/-BO/-BOS2)	
R88M-1AL1K530T(-S2/-O/-OS2/-B/-BS2/-BO/-BOS2)	
R88M-1AL1K530C(-S2/-O/-OS2/-B/-BS2/-BO/-BOS2)	
R88M-1AL2K030T(-S2/-O/-OS2/-B/-BS2/-BO/-BOS2)	
R88M-1AL2K030C(-S2/-O/-OS2/-B/-BS2/-BO/-BOS2)	
R88M-1AL2K630T(-S2/-O/-OS2/-B/-BS2/-BO/-BOS2)	
R88M-1AL3K030C(-S2/-O/-OS2/-B/-BS2/-BO/-BOS2)	
R88M-1AM1K515T(-S2/-O/-OS2/-B/-BS2/-BO/-BOS2)	
R88M-1AM1K515C(-S2/-O/-OS2/-B/-BS2/-BO/-BOS2)	
R88M-1AM2K715T(-S2/-O/-OS2/-B/-BS2/-BO/-BOS2)	
R88M-1AM3K015C(-S2/-O/-OS2/-B/-BS2/-BO/-BOS2)	

R88G-HPG□/VRXF□

Contents

- Ordering Information
- Specifications
- External Dimensions

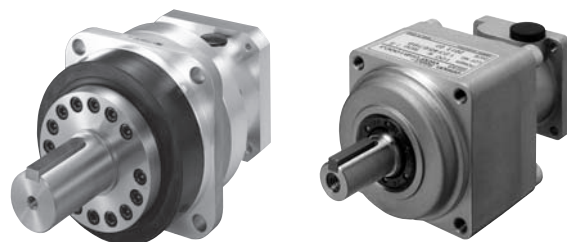

Ordering Information

Refer to the Ordering Information.

Specifications

Backlash: 3 Arcminutes Max.
For 3,000-r/min Servomotors

Servomotor rated output	Reduction ratio	Model	Rated rotation speed	Rated torque	Efficiency	Momentary maximum rotation speed	Momentary maximum torque	Decelerator inertia	Allowable radial load	Allowable thrust load	Weight
			r/min	N·m	%	r/min	N·m	$\times 10^{-4}$ kg·m ²	N	N	kg
200 W	1/5	R88G-HPG14A05200B□	600	2.4	75.4	1200	9.7	0.207	221	883	1.0
	1/11	R88G-HPG14A11200B□	272	5.8	82.6	545	21.8	0.197	280	1119	1.1
	1/21	R88G-HPG20A21200B□	142	10.2	76.2	285	41.7	0.49	800	2817	2.9
	1/33	R88G-HPG20A33200B□	90	17.0	80.6	181	66.5	0.45	916	3226	2.9
	1/45	R88G-HPG20A45200B□	66	23.5	82.1	133	91.1	0.45	1006	3541	2.9
400 W	1/5	R88G-HPG14A05400B□	600	5.3	84.2	1200	20.4	0.207	221	883	1.1
	1/11	R88G-HPG20A11400B□	272	11.4	81.6	545	45.5	0.57	659	2320	2.9
	1/21	R88G-HPG20A21400B□	142	23.0	86.1	285	88.1	0.49	800	2817	2.9
	1/33	R88G-HPG32A33400B□	90	33.8	80.7	181	136.2	0.62	1565	6240	7.5
	1/45	R88G-HPG32A45400B□	66	46.6	81.5	133	186.1	0.61	1718	6848	7.5
750 W (200 V)	1/5	R88G-HPG20A05750B□	600	9.9	82.9	1200	38.7	0.68	520	1832	2.9
	1/11	R88G-HPG20A11750B□	272	20.0 *1	87.2	545	86.7	0.6	659	2320	3.1
	1/21	R88G-HPG32A21750B□	142	42.1	84.0	285	163.3	3.0	1367	5448	7.8
	1/33	R88G-HPG32A33750B□	90	69.3	87.9	181	259.7	2.7	1565	6240	7.8
750 W (400 V)	1/5	R88G-HPG32A052K0B□	600	7.7	64.3	1000	30.6	3.8	889	3542	7.4
	1/11	R88G-HPG32A112K0B□	272	20.5	78.0	454	70.9	3.4	1126	4488	7.9
	1/21	R88G-HPG32A211K5B□	142	42.1	84.0	238	138.3	3.0	1367	5448	7.9
1 kW	1/5	R88G-HPG32A052K0B□	600	11.5	72.2	1000	42.0	3.8	889	3542	7.4
	1/11	R88G-HPG32A112K0B□	272	28.9	82.5	454	96.1	3.4	1126	4488	7.9
	1/21	R88G-HPG32A211K5B□	142	58.1	86.9	238	186.5	3.0	1367	5448	7.9

AC Servo System 1S-series with Safety Functionality

Servomotor rated output	Reduction ratio	Model	Rated rotation speed	Rated torque	Efficiency	Momentary maximum rotation speed	Momentary maximum torque	Decelerator inertia	Allowable radial load	Allowable thrust load	Weight
			r/min	N·m	%	r/min	N·m	$\times 10^{-4}$ kg·m ²	N	N	kg
1.5 kW	1/5	R88G-HPG32A052K0B□	600	19.1	80.1	1000	64.8	3.8	889	3542	7.4
	1/11	R88G-HPG32A112K0B□	272	45.7	87.0	454	146.3	3.4	1126	4488	7.9
	1/21	R88G-HPG32A211K5B□	142	90.1	90.0	238	282.2	3.0	1367	5448	7.9
	1/33	R88G-HPG50A332K0B□	90	141.3	89.8	151	443.2	4.8	4135	14300	19.0
	1/45	R88G-HPG50A451K5B□	66	194.8	90.8	111	606.5	4.7	4538	15694	19.0
2 kW	1/5	R88G-HPG32A052K0B□	600	26.8	84.1	1000	87.9	3.8	889	3542	7.4
	1/11	R88G-HPG32A112K0B□	272	62.5	89.3	454	197.0	3.4	1126	4488	7.9
2.6 kW (200 V)	1/5	R88G-HPG32A053K0B□	600	36.0	86.8	1000	115.2	3.8	889	3542	7.3
3 kW (400 V)	1/5	R88G-HPG32A053K0B□	600	42.0	88.1	1000	134.0	3.8	889	3542	7.3

*1. The value is the allowable continuous output torque of the Decelerator. Take care so that this value is not exceeded.

*2. The value is the maximum allowable torque of the Decelerator. Take care so that this value is not exceeded.

Note: 1. The Decelerator inertia is the Servomotor shaft conversion value.

2. The protective structure rating of the Servomotor with the Decelerator is IP44.

3. The Allowable radial load column shows the values obtained at the center of the shaft (T/2).

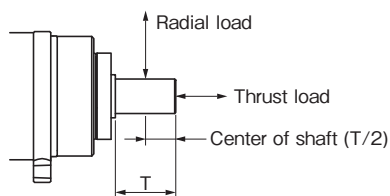

4. The standard shaft type is a straight shaft. A model with a key and tap is indicated with "J" at □ of the model number.

5. Take care so that the surface temperature of the Decelerator does not exceed 70°C.

For 1,500-r/min Servomotors

Servomotor rated output	Reduction ratio	Model	Rated rotation speed	Rated torque	Efficiency	Momentary maximum rotation speed	Momentary maximum torque	Decelerator inertia	Allowable radial load	Allowable thrust load	Weight
			r/min	N·m	%	r/min	N·m	$\times 10^{-4}$ kg·m ²	N	N	kg
1.5 kW	1/5	R88G-HPG32A053K0B□	300	43.8	91.7	600	135.7	3.8	889	3542	7.3
	1/11	R88G-HPG32A112K0SB□	136	98.1	93.4	272	299.0 *1	3.4	1126	4488	7.8
	1/21	R88G-HPG50A21900TB□	71	187.2	93.3	142	573.2	7.0	3611	12486	19.1
	1/33	R88G-HPG50A33900TB□	45	294.1 *2	94.1	90	849.0 *1	5.9	4135	14300	19.1
2.7 kW (200 V)	1/5	R88G-HPG50A055K0SB□	300	79.2	92.1	600	244.3	11	2347	8118	22.0
	1/11	R88G-HPG50A115K0SB□	136	177.8	94.0	272	541.1	8.4	2974	10285	23.5
	1/20	R88G-HPG65A205K0SB□	75	315.6	91.7	150	976.0	14	7338	26799	55.4
	1/25	R88G-HPG65A255K0SB□	60	396.8	92.3	120	1222.4	14	7846	28654	55.4
3 kW (400 V)	1/5	R88G-HPG50A055K0SB□	300	88.3	92.5	600	271.7	11	2347	8118	22.0
	1/11	R88G-HPG50A115K0SB□	136	197.9	94.2	272	601.2	8.4	2974	10285	23.5
	1/20	R88G-HPG65A205K0SB□	75	352.0	92.2	150	1085.5	14	7338	26799	55.4
	1/25	R88G-HPG65A255K0SB□	60	442.4	92.7	120	1359.2	14	7846	28654	55.4

*1. The value is the allowable continuous output torque of the Decelerator. Take care so that this value is not exceeded.

*2. The value is the maximum allowable torque of the Decelerator. Take care so that this value is not exceeded.

Note: 1. The Decelerator inertia is the Servomotor shaft conversion value.

2. The protective structure rating of the Servomotor with the Decelerator is IP44.

3. The Allowable radial load column shows the values obtained at the center of the shaft (T/2).

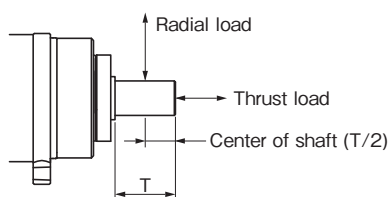

4. The standard shaft type is a straight shaft. A model with a key and tap is indicated with "J" at □ of the model number.

5. Take care so that the surface temperature of the Decelerator does not exceed 70°C.

AC Servo System 1S-series with Safety Functionality

Backlash: 15 Arcminutes Max.

For 3,000-r/min Servomotors

Servomotor rated output	Reduction ratio	Model	Rated rotation speed	Rated torque	Efficiency	Momentary maximum rotation speed	Momentary maximum torque	Decelerator inertia	Allowable radial load	Allowable thrust load	Weight
			r/min	N·m	%	r/min	N·m	$\times 10^{-4}$ kg·m ²	N	N	kg
200 W	1/5	R88G-VRXF05B200CJ	600	2.93	92	1200	9.94 *	0.147	392	196	0.72
	1/9	R88G-VRXF09C200CJ	333	4.76	83	667	16.43	0.273	931	465	1.70
	1/15	R88G-VRXF15C200CJ	200	8.22	86	400	28.38	0.302	1176	588	2.10
	1/25	R88G-VRXF25C200CJ	120	13.70	86	240	47.30	0.293	1323	661	2.10
400 W	1/5	R88G-VRXF05C400CJ	600	5.59	88	1200	19.80	0.370	784	392	1.70
	1/9	R88G-VRXF09C400CJ	333	10.06	88	667	34.00 *	0.273	931	465	1.70
	1/15	R88G-VRXF15C400CJ	200	16.95	89	400	56.70 *	0.302	1176	588	2.10
	1/25	R88G-VRXF25C400CJ	120	28.26	89	240	92.40 *	0.293	1323	661	2.10
750 W (200 V)	1/5	R88G-VRXF05C750CJ	600	10.99	92	1200	38.64	0.817	784	392	2.10
	1/9	R88G-VRXF09D750CJ	333	19.57	91	667	63.70 *	0.755	1176	588	3.40
	1/15	R88G-VRXF15D750CJ	200	31.91	89	400	106.00 *	0.685	1372	686	3.80
	1/25	R88G-VRXF25D750CJ	120	53.18	89	240	177.00 *	0.658	1617	808	3.80

* The value is the maximum allowable torque of the Decelerator. Take care so that this value is not exceeded.

- Note:**
1. The Decelerator inertia is the Servomotor shaft conversion value.
 2. The protective structure rating of the Servomotor combined with the Decelerator is IP44.
(Excluding decelerator and servo motor connecting parts.)
 3. The Allowable radial load column shows the values obtained at the center of the shaft (T/2).

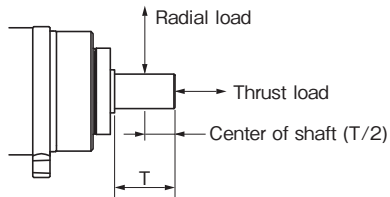

4. The standard shaft type is a shaft with key and tap. (The key is temporarily assembled to the shaft.)
5. Take care so that the surface temperature of the Decelerator does not exceed 90°C.

AC Servo System 1S-series with Safety Functionality

External Dimensions

(Unit: mm)

Backlash: 3 Arcminutes Max.
For 3,000-r/min Servomotors (200 to 750 W)

Servomotor rated output	Reduction ratio	Model	Outline Drawing	Dimensions [mm]												
				LM	LR	C1	C2	D1	D2	D3	D4	D5	D6 *1	E	F1	F2
200 W	1/5	R88G-HPG14A05200B□	1	64.0	58	60	60 × 60	70	70	56	55.5	40	---	37	2.5	21
	1/11	R88G-HPG14A11200B□	1	64.0	58	60	60 × 60	70	70	56	55.5	40	---	37	2.5	21
	1/21	R88G-HPG20A21200B□	2	71.0	80	90	89 dia.	105	70	85	84	59	---	53	7.5	27
	1/33	R88G-HPG20A33200B□	2	71.0	80	90	89 dia.	105	70	85	84	59	---	53	7.5	27
	1/45	R88G-HPG20A45200B□	2	71.0	80	90	89 dia.	105	70	85	84	59	---	53	7.5	27
400 W	1/5	R88G-HPG14A05400B□	1	64	58	60	60 × 60	70	70	56	55.5	40	---	37	2.5	21
	1/11	R88G-HPG20A11400B□	2	71	80	90	89 dia.	105	70	85	84	59	---	53	7.5	27
	1/21	R88G-HPG20A21400B□	2	71	80	90	89 dia.	105	70	85	84	59	---	53	7.5	27
	1/33	R88G-HPG32A33400B□	2	104	133	120	122 dia.	135	70	115	114	84	---	98	12.5	35
	1/45	R88G-HPG32A45400B□	2	104	133	120	122 dia.	135	70	115	114	84	---	98	12.5	35
750 W (200 V)	1/5	R88G-HPG20A05750B□	1	78	80	90	80 × 80	105	90	85	84	59	89	53	7.5	27
	1/11	R88G-HPG20A11750B□	1	78	80	90	80 × 80	105	90	85	84	59	89	53	7.5	27
	1/21	R88G-HPG32A21750B□	2	104	133	120	122 dia.	135	90	115	114	84	---	98	12.5	35
	1/33	R88G-HPG32A33750B□	2	104	133	120	122 dia.	135	90	115	114	84	---	98	12.5	35
	1/45	R88G-HPG32A45750B□	2	104	133	120	122 dia.	135	90	115	114	84	---	98	12.5	35
750 W (400 V)	1/5	R88G-HPG32A052K0B□	2	110	133	120	135 dia.	135	115	115	114	84	---	98	12.5	35
	1/11	R88G-HPG32A112K0B□	2	110	133	120	135 dia.	135	115	115	114	84	---	98	12.5	35
	1/21	R88G-HPG32A211K5B□	2	110	133	120	135 dia.	135	115	115	114	84	---	98	12.5	35
	1/33	R88G-HPG32A33600SB□	2	110	133	120	135 dia.	135	115	115	114	84	---	98	12.5	35

Servomotor rated output	Reduction ratio	Model	Dimensions [mm]											
			G	S	T	Z1	Z2	AT *2	Key				Tap	
									QK	b	h	t1	M	L
200 W	1/5	R88G-HPG14A05200B□	8	16	28	5.5	M4 × 10	M4	25	5	5	3	M4	8
	1/11	R88G-HPG14A11200B□	8	16	28	5.5	M4 × 10	M4	25	5	5	3	M4	8
	1/21	R88G-HPG20A21200B□	10	25	42	9	M4 × 10	M4	36	8	7	4	M6	12
	1/33	R88G-HPG20A33200B□	10	25	42	9	M4 × 10	M4	36	8	7	4	M6	12
	1/45	R88G-HPG20A45200B□	10	25	42	9	M4 × 10	M4	36	8	7	4	M6	12
400 W	1/5	R88G-HPG14A05400B□	8	16	28	5.5	M4 × 10	M4	25	5	5	3	M4	8
	1/11	R88G-HPG20A11400B□	10	25	42	9	M4 × 10	M4	36	8	7	4	M6	12
	1/21	R88G-HPG20A21400B□	10	25	42	9	M4 × 10	M4	36	8	7	4	M6	12
	1/33	R88G-HPG32A33400B□	13	40	82	11	M4 × 10	M4	70	12	8	5	M10	20
	1/45	R88G-HPG32A45400B□	13	40	82	11	M4 × 10	M4	70	12	8	5	M10	20
750 W (200 V)	1/5	R88G-HPG20A05750B□	10	25	42	9	M5 × 12	M4	36	8	7	4	M6	12
	1/11	R88G-HPG20A11750B□	10	25	42	9	M5 × 12	M4	36	8	7	4	M6	12
	1/21	R88G-HPG32A21750B□	13	40	82	11	M5 × 12	M6	70	12	8	5	M10	20
	1/33	R88G-HPG32A33750B□	13	40	82	11	M5 × 12	M6	70	12	8	5	M10	20
	1/45	R88G-HPG32A45750B□	13	40	82	11	M5 × 12	M6	70	12	8	5	M10	20
750 W (400 V)	1/5	R88G-HPG32A052K0B□	13	40	82	11	M8 × 10	M6	70	12	8	5	M10	20
	1/11	R88G-HPG32A112K0B□	13	40	82	11	M8 × 10	M6	70	12	8	5	M10	20
	1/21	R88G-HPG32A211K5B□	13	40	82	11	M8 × 10	M6	70	12	8	5	M10	20
	1/33	R88G-HPG32A33600SB□	13	40	82	11	M8 × 10	M6	70	12	8	5	M10	20

*1. D6 is the maximum diameter of the decelerator body between the flange side and Servomotor side. (See Outline Drawing) The value is given only when the diameter is larger than the diameters of these two sides. Take heed of this when you mount the decelerator to the machine.

*2. Indicates set bolt.

Note: 1. The standard shaft type is a straight shaft.

2. A model with a key and tap is indicated with "J" at □ of the model number. (Example: R88G-HPG14A05400BJ)

3. The diameter of the motor shaft insertion hole is the same as the shaft diameter of the corresponding Servomotor.

4. You cannot use this type of Decelerator for the Servomotor with key.

5. The dimensional drawings in this document are for showing main dimensions only, and they do not give the details of the product shape.

AC Servo System 1S-series with Safety Functionality

Outline Drawing 1

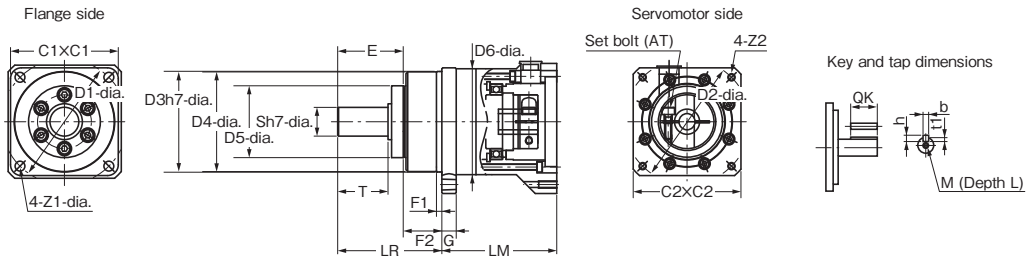

Outline Drawing 2

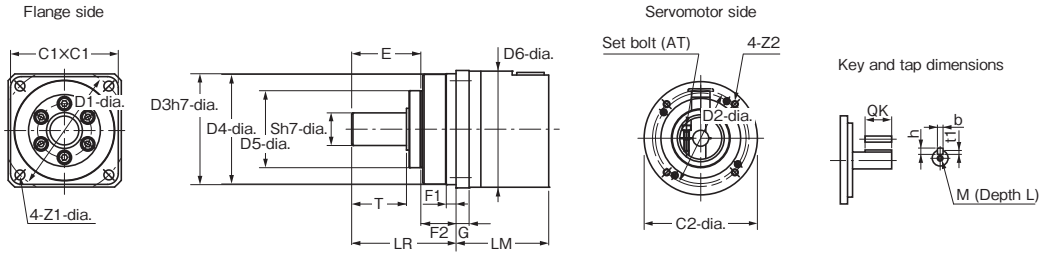

AC Servo System 1S-series with Safety Functionality

For 3,000-r/min Servomotors (1 to 3 kW)

Servomotor rated output	Reduction ratio	Model	Outline Drawing	Dimensions [mm]												
				LM	LR	C1	C2	D1	D2	D3	D4	D5	D6 #1	E	F1	F2
1 kW	1/5	R88G-HPG32A052K0B□	2	110	133	120	135 dia.	135	115	115	114	84	---	98	12.5	35
	1/11	R88G-HPG32A112K0B□	2	110	133	120	135 dia.	135	115	115	114	84	---	98	12.5	35
	1/21	R88G-HPG32A211K5B□	2	110	133	120	135 dia.	135	115	115	114	84	---	98	12.5	35
1.5 kW	1/5	R88G-HPG32A052K0B□	2	110	133	120	135 dia.	135	115	115	114	84	---	98	12.5	35
	1/11	R88G-HPG32A112K0B□	2	110	133	120	135 dia.	135	115	115	114	84	---	98	12.5	35
	1/21	R88G-HPG32A211K5B□	2	110	133	120	135 dia.	135	115	115	114	84	---	98	12.5	35
2 kW	1/5	R88G-HPG32A052K0B□	2	110	133	120	135 dia.	135	115	115	114	84	---	98	12.5	35
	1/11	R88G-HPG32A112K0B□	2	110	133	120	135 dia.	135	115	115	114	84	---	98	12.5	35
2.6 kW (200 V) 3 kW (400 V)	1/5	R88G-HPG32A053K0B□	1	107	133	120	130 × 130	135	145	115	114	84	---	98	12.5	35

Servomotor rated output	Reduction ratio	Model	Dimensions [mm]											
			G	S	T	Z1	Z2	AT #2	Key				Tap	
									QK	b	h	t1	M	L
1 kW	1/5	R88G-HPG32A052K0B□	13	40	82	11	M8 × 10	M6	70	12	8	5	M10	20
	1/11	R88G-HPG32A112K0B□	13	40	82	11	M8 × 10	M6	70	12	8	5	M10	20
	1/21	R88G-HPG32A211K5B□	13	40	82	11	M8 × 10	M6	70	12	8	5	M10	20
1.5 kW	1/5	R88G-HPG32A052K0B□	13	40	82	11	M8 × 10	M6	70	12	8	5	M10	20
	1/11	R88G-HPG32A112K0B□	13	40	82	11	M8 × 10	M6	70	12	8	5	M10	20
	1/21	R88G-HPG32A211K5B□	13	40	82	11	M8 × 10	M6	70	12	8	5	M10	20
2 kW	1/5	R88G-HPG32A052K0B□	13	40	82	11	M8 × 10	M6	70	12	8	5	M10	20
	1/11	R88G-HPG32A112K0B□	13	40	82	11	M8 × 10	M6	70	12	8	5	M10	20
2.6 kW (200 V) 3 kW (400V)	1/5	R88G-HPG32A053K0B□	13	40	82	11	M8 × 18	M6	70	12	8	5	M10	20

*1. D6 is the maximum diameter of the decelerator body between the flange side and Servomotor side. (See Outline Drawing) The value is given only when the diameter is larger than the diameters of these two sides. Take heed of this when you mount the decelerator to the machine.

*2. Indicates set bolt.

Note: 1. The standard shaft type is a straight shaft.

2. A model with a key and tap is indicated with "J" at □ of the model number. (Example: R88G-HPG32A052K0BJ)

3. The diameter of the motor shaft insertion hole is the same as the shaft diameter of the corresponding Servomotor.

4. You cannot use this type of Decelerator for the Servomotor with key.

5. The dimensional drawings in this document are for showing main dimensions only, and they do not give the details of the product shape.

Outline Drawing 1

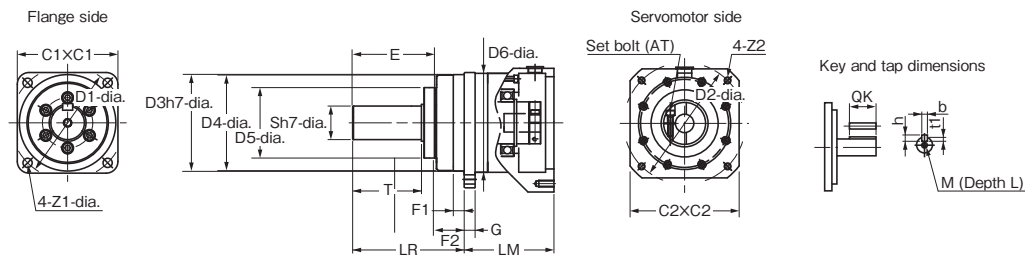

Outline Drawing 2

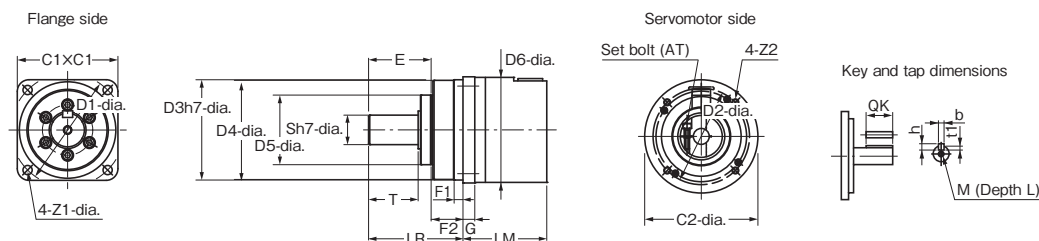

AC Servo System 1S-series with Safety Functionality

For 1,500-r/min Servomotors (1.5 to 3 kW)

Servomotor rated output	Reduction ratio	Model	Outline Drawing	Dimensions [mm]												
				LM	LR	C1	C2	D1	D2	D3	D4	D5	D6 *1	E	F1	F2
1.5 kW	1/5	R88G-HPG32A053K0B□	1	107	133	120	130 × 130	135	145	115	114	84	---	98	12.5	35
	1/11	R88G-HPG32A112K0SB□	1	107	133	120	130 × 130	135	145	115	114	84	---	98	12.5	35
	1/21	R88G-HPG50A21900TB□	1	149	156	170	130 × 130	190	145	165	163	122	170	103	12	53
	1/33	R88G-HPG50A33900TB□	1	149	156	170	130 × 130	190	145	165	163	122	170	103	12	53
2.7 kW (200 V) 3 kW (400 V)	1/5	R88G-HPG50A055K0SB□	1	149	156	170	180 × 180	190	200	165	163	122	---	103	12	53
	1/11	R88G-HPG50A115K0SB□	1	149	156	170	180 × 180	190	200	165	163	122	---	103	12	53
	1/20	R88G-HPG65A205K0SB□	1	231	222	230	180 × 180	260	200	220	214	168	220	165	12	57
	1/25	R88G-HPG65A255K0SB□	1	231	222	230	180 × 180	260	200	220	214	168	220	165	12	57

Servomotor rated output	Reduction ratio	Model	Dimensions [mm]											
			G	S	T	Z1	Z2	AT *2	Key				Tap	
									QK	b	h	t1	M	L
1.5 kW	1/5	R88G-HPG32A053K0B□	13	40	82	11	M8 × 18	M6	70	12	8	5	M10	20
	1/11	R88G-HPG32A112K0SB□	13	40	82	11	M8 × 18	M6	70	12	8	5	M10	20
	1/21	R88G-HPG50A21900TB□	16	50	82	14	M8 × 25	M6	70	14	9	5.5	M10	20
	1/33	R88G-HPG50A33900TB□	16	50	82	14	M8 × 25	M6	70	14	9	5.5	M10	20
2.7 kW (200 V) 3 kW (400 V)	1/5	R88G-HPG50A055K0SB□	16	50	82	14	M12 × 25	M6	70	14	9	5.5	M10	20
	1/11	R88G-HPG50A115K0SB□	16	50	82	14	M12 × 25	M6	70	14	9	5.5	M10	20
	1/20	R88G-HPG65A205K0SB□	25	80	130	18	M12 × 25	M8	110	22	14	9	M16	35
	1/25	R88G-HPG65A255K0SB□	25	80	130	18	M12 × 25	M8	110	22	14	9	M16	35

*1. D6 is the maximum diameter of the decelerator body between the flange side and Servomotor side. (See Outline Drawing) The value is given only when the diameter is larger than the diameters of these two sides. Take heed of this when you mount the decelerator to the machine.

*2. Indicates set bolt.

Note: 1. The standard shaft type is a straight shaft.

2. A model with a key and tap is indicated with "J" at □ of the model number. (Example: R88G-HPG32A05900TBJ)

3. The diameter of the motor shaft insertion hole is the same as the shaft diameter of the corresponding Servomotor.

4. You cannot use this type of Decelerator for the Servomotor with key.

5. The dimensional drawings in this document are for showing main dimensions only, and they do not give the details of the product shape.

Outline Drawing

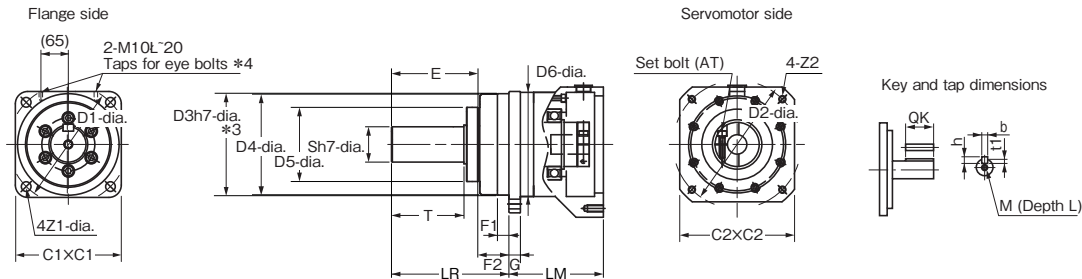

*3. The tolerance is "h8" for R88G-HPG50□ and R88G-HPG65□.

*4. The model R88G-HPG65□ has the taps for eye bolts.

AC Servo System 1S-series with Safety Functionality

Backlash: 15 Arcminutes Max. For 3,000-r/min Servomotors

Model			Dimensions [mm]										
			LM	LR	C1	C2	D1	D2	D3	F	G	S	T
200 W	1/5	R88G-VRXF05B200CJ	72.5	32	60	52	70	60	50	3	10	12	20
	1/9	R88G-VRXF09C200CJ	89.5	50	60	78	70	90	70	3	8	19	30
	1/15	R88G-VRXF15C200CJ	100.0	50	60	78	70	90	70	3	8	19	30
	1/25	R88G-VRXF25C200CJ	100.0	50	60	78	70	90	70	3	8	19	30
400 W	1/5	R88G-VRXF05C400CJ	89.5	50	60	78	70	90	70	3	8	19	30
	1/9	R88G-VRXF09C400CJ	89.5	50	60	78	70	90	70	3	8	19	30
	1/15	R88G-VRXF15C400CJ	100.0	50	60	78	70	90	70	3	8	19	30
	1/25	R88G-VRXF25C400CJ	100.0	50	60	78	70	90	70	3	8	19	30
750 W (200 V)	1/5	R88G-VRXF05C750CJ	93.5	50	80	78	90	90	70	3	10	19	30
	1/9	R88G-VRXF09D750CJ	97.5	61	80	98	90	115	90	5	10	24	40
	1/15	R88G-VRXF15D750CJ	110.0	61	80	98	90	115	90	5	10	24	40
	1/25	R88G-VRXF25D750CJ	110.0	61	80	98	90	115	90	5	10	24	40

Model			Dimensions [mm]									
			Z1	Z2	AT *	L	Key				Tap	
							QK	b	h	t1	m	l
200 W	1/5	R88G-VRXF05B200CJ	M4	M5	M4	12	16	4	4	2.5	M5	10
	1/9	R88G-VRXF09C200CJ	M4	M6	M5	20	22	6	6	3.5	M6	12
	1/15	R88G-VRXF15C200CJ	M4	M6	M5	20	22	6	6	3.5	M6	12
	1/25	R88G-VRXF25C200CJ	M4	M6	M5	20	22	6	6	3.5	M6	12
400 W	1/5	R88G-VRXF05C400CJ	M4	M6	M5	20	22	6	6	3.5	M6	12
	1/9	R88G-VRXF09C400CJ	M4	M6	M5	20	22	6	6	3.5	M6	12
	1/15	R88G-VRXF15C400CJ	M4	M6	M5	20	22	6	6	3.5	M6	12
	1/25	R88G-VRXF25C400CJ	M4	M6	M5	20	22	6	6	3.5	M6	12
750 W (200 V)	1/5	R88G-VRXF05C750CJ	M5	M6	M6	20	22	6	6	3.5	M6	12
	1/9	R88G-VRXF09D750CJ	M5	M8	M6	20	30	8	7	4	M8	16
	1/15	R88G-VRXF15D750CJ	M5	M8	M6	20	30	8	7	4	M8	16
	1/25	R88G-VRXF25D750CJ	M5	M8	M6	20	30	8	7	4	M8	16

* Indicates set bolt.

Note: 1. The standard shaft type is a shaft with key and tap.

2. The diameter of the motor shaft insertion hole is the same as the shaft diameter of the corresponding Servomotor.

3. You cannot use this type of Decelerator for the Servomotor with key.

4. The dimensional drawings in this document are for showing main dimensions only, and they do not give the details of the product shape.

Outline Drawing

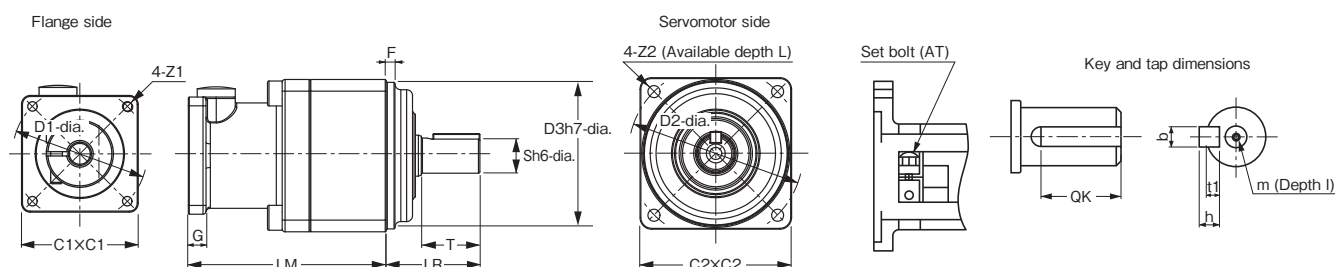

MEMO

Ordering Information

Interpreting Model Numbers	46
AC Servo Drives with Built-in EtherCAT	46
AC Servomotor.....	46
Decelerator.....	47
Table of AC Servomotor Variations.....	48
Ordering Information	48
AC Servo Drives with Built-in EtherCAT Communications and Safety Functionality	48
AC Servomotors with Safety Functionality.....	49
Decelerator (Backlash: 3 Arcminutes Max./15 Arcminutes Max.)	50
Cables and Peripheral Devices.....	51
Software	55
Combination table	55
Cable Connection Configuration	57
Related Manuals	60
Sizing Tool for AC Servo Motors	61

AC Servo System 1S-series with Safety Functionality

Interpreting Model Numbers

AC Servo Drives with Built-in EtherCAT R88D-1S AN 02 H -ECT

(1) (2) (3) (4) (5)

No	Item	Symbol	Specifications
(1)	1S-series Servo Drive		
(2)	Servo Drive type	N	Standard / Communication type *
		AN	Advance / Communications type
(3)	Applicable Servomotor rated output	02	200 W
		04	400 W
		08	750 W
		10	1 kW
		15	1.5 kW
		20	2 kW
		30	3 kW
(4)	Power Supply Voltage	H	200 VAC
		F	400 VAC
(5)	Communications type	ECT	EtherCAT Communications

* For details of the 1S-series Standard / Communication type *, refer to the *AC Servo System 1S Series CATALOG* (Cat. No. I821).

AC Servomotor R88M-1 AM 200 30 T -BOS2

(1) (2) (3) (4) (5) (6)

No	Item	Symbol	Specifications
(1)	1S-series Servomotor		
(2)	Servomotor Type	L	Standard / Low-inertia type *
		M	Standard / Middle-inertia type *
		AL	Advance / Low-inertia type
		AM	Advance / Middle-inertia type
(3)	Rated output	200	200 W
		400	400 W
		750	750 W
		1K0	1 kW
		1K5	1.5 kW
		2K0	2 kW
		2K6	2.6 kW
		2K7	2.7 kW
		3K0	3 kW
		(4)	Rated rotation speed
30	3000 r/min		
(5)	Servo Drive main power supply voltage and encoder type	T	200 VAC absolute encoder
		C	400 VAC absolute encoder
(6)	Options		
	Brake	None	Without brake
		B	With 24-VDC brake
	Oil seal	None	Without oil seal
		O	With oil seal
	Key and tap	None	Straight shaft
S2		With key and tap	

* For details of the 1S-series Standard / Low-inertia type and Standard / Middle-inertia type, refer to the *AC Servo System 1S Series CATALOG* (Cat. No. I821).

AC Servo System 1S-series with Safety Functionality

Decelerator

Backlash: 3 Arcminutes Max.

R88G-HPG 32A 11 2K0 S B J

(1) (2) (3) (4) (5) (6) (7)

No	Item	Symbol	Specifications
(1)	Decelerator for Servomotor Backlash: 3 Arcminutes max.		
(2)	Flange size number	14A	60 × 60
		20A	90 × 90
		32A	120 × 120
		50A	170 × 170
		65A	230 × 230
(3)	Reduction ratio	05	1/5
		11	1/11
		20	1/20
		21	1/21
		25	1/25
		33	1/33
(4)	Applicable Servomotor rated output *	45	1/45
		200	200 W
		400	400 W
		600	600 W
		750	750 W
		900	900 W
		1K5	1.5 kW
		2K0	2 kW
		3K0	3 kW
(5)	Motor type *	None	3,000-r/min Servomotors
		S	2,000-r/min Servomotors
		T	1,000-r/min Servomotors
(6)	Backlash	B	Backlash: 3 Arcminutes max.
(7)	Option	None	Straight shaft
		J	With key and tap

* This is a standard model number of servo motor; this model number structure can be applied to other motors. Confirm decelerator and servomotor combination table when you select a Servomotor.

Backlash: 15 Arcminutes Max.

R88G-VRXF 05 B 200 C J

(1) (2) (3) (4) (5) (6)

No	Item	Symbol	Specifications
(1)	Decelerator for Servomotor Backlash: 15 Arcminutes max.		
(2)	Gear Ratio	05	1/5
		09	1/9
		15	1/15
		25	1/25
(3)	Flange Size Number	B	52 × 52
		C	78 × 78
		D	98 × 98
(4)	Applicable Servomotor rated output	200	200 W
		400	400 W
		750	750 W
(5)	Backlash	C	Backlash: 15 Arcminutes Max
(6)	Option	J	With key and tap

AC Servo System 1S-series with Safety Functionality

Table of AC Servomotor Variations

R88M-1 -

(2) (3) (4) (5) (6) (7) (8)

Type	Rated output	Rotation speed	Model	Power supply specifications			Brake		Oil seal		Shaft type	
				ABS	ABS	ABS	None	B	None	O	None	S2
				400	200	100						
				C	T	S						
AM	200 W	3000 r/min	R88M-1AM20030		✓		✓	✓	✓	✓	✓	
	400 W		R88M-1AM40030		✓		✓	✓	✓	✓	✓	
	750 W		R88M-1AM75030		✓		✓	✓	✓	✓	✓	
AL	750 W		R88M-1AL75030	✓			✓	✓	✓	✓	✓	✓
	1 kW		R88M-1AL1K030	✓	✓		✓	✓	✓	✓	✓	✓
	1.5 kW		R88M-1AL1K530	✓	✓		✓	✓	✓	✓	✓	✓
	2 kW		R88M-1AL2K030	✓	✓		✓	✓	✓	✓	✓	✓
	2.6 kW		R88M-1AL2K630		✓		✓	✓	✓	✓	✓	✓
AM	3 kW		R88M-1AL3K030	✓			✓	✓	✓	✓	✓	✓
	1.5 kW		1500 r/min	R88M-1AM1K515	✓	✓		✓	✓	✓	✓	✓
		R88M-1AM2K715			✓		✓	✓	✓	✓	✓	
2.7 kW	R88M-1AM3K015	✓				✓	✓	✓	✓	✓		
3 kW												
AM: Middle inertia AL: Low inertia	200: 200 W 1K0: 1 kW 3K0: 3 kW	15: 1500 r/min 30: 3000 r/min		C: 400 VAC (with absolute encoder) ABS/INC T: 200 VAC (with absolute encoder) ABS/INC S: 100 VAC (with absolute encoder) ABS/INC			None: Without brake B: With 24-VDC brake		None: Without oil seal O: With oil seal		None: Straight shaft S2: With key and tap	

Ordering Information

AC Servo Drives with Built-in EtherCAT Communications and Safety Functionality

Power supply voltage	Rated output	Model
Single-phase/3-phase 200 VAC	200 W	R88D-1SAN02H-ECT
	400 W	R88D-1SAN04H-ECT
	750 W	R88D-1SAN08H-ECT
	1.5 kW	R88D-1SAN15H-ECT
3-phase 200 VAC	1 kW	R88D-1SAN10H-ECT
	2 kW	R88D-1SAN20H-ECT
	3 kW	R88D-1SAN30H-ECT
3-phase 400 VAC	1 kW	R88D-1SAN10F-ECT
	1.5 kW	R88D-1SAN15F-ECT
	2 kW	R88D-1SAN20F-ECT
	3 kW	R88D-1SAN30F-ECT

AC Servo System 1S-series with Safety Functionality

AC Servomotors with Safety Functionality 3,000-r/min Servomotors

Specifications			Model			
			Without oil seal			
			Straight shaft	With key and tap		
Without brake	200 VAC	200 W	R88M-1AM20030T	R88M-1AM20030T-S2		
		400 W	R88M-1AM40030T	R88M-1AM40030T-S2		
		750 W	R88M-1AM75030T	R88M-1AM75030T-S2		
		1 kW	R88M-1AL1K030T	R88M-1AL1K030T-S2		
		1.5 kW	R88M-1AL1K530T	R88M-1AL1K530T-S2		
		2 kW	R88M-1AL2K030T	R88M-1AL2K030T-S2		
		2.6 kW	R88M-1AL2K630T	R88M-1AL2K630T-S2		
	400 VAC	750 W	R88M-1AL75030C	R88M-1AL75030C-S2		
		1 kW	R88M-1AL1K030C	R88M-1AL1K030C-S2		
		1.5 kW	R88M-1AL1K530C	R88M-1AL1K530C-S2		
		2 kW	R88M-1AL2K030C	R88M-1AL2K030C-S2		
		3 kW	R88M-1AL3K030C	R88M-1AL3K030C-S2		
		With brake	200 VAC	200 W	R88M-1AM20030T-B	R88M-1AM20030T-BS2
				400 W	R88M-1AM40030T-B	R88M-1AM40030T-BS2
750 W	R88M-1AM75030T-B			R88M-1AM75030T-BS2		
1 kW	R88M-1AL1K030T-B			R88M-1AL1K030T-BS2		
1.5 kW	R88M-1AL1K530T-B			R88M-1AL1K530T-BS2		
2 kW	R88M-1AL2K030T-B			R88M-1AL2K030T-BS2		
2.6 kW	R88M-1AL2K630T-B			R88M-1AL2K630T-BS2		
400 VAC	750 W		R88M-1AL75030C-B	R88M-1AL75030C-BS2		
	1 kW		R88M-1AL1K030C-B	R88M-1AL1K030C-BS2		
	1.5 kW		R88M-1AL1K530C-B	R88M-1AL1K530C-BS2		
	2 kW		R88M-1AL2K030C-B	R88M-1AL2K030C-BS2		
	3 kW		R88M-1AL3K030C-B	R88M-1AL3K030C-BS2		

Specifications			Model			
			With oil seal			
			Straight shaft	With key and tap		
Without brake	200 VAC	200 W	R88M-1AM20030T-O	R88M-1AM20030T-OS2		
		400 W	R88M-1AM40030T-O	R88M-1AM40030T-OS2		
		750 W	R88M-1AM75030T-O	R88M-1AM75030T-OS2		
		1 kW	R88M-1AL1K030T-O	R88M-1AL1K030T-OS2		
		1.5 kW	R88M-1AL1K530T-O	R88M-1AL1K530T-OS2		
		2 kW	R88M-1AL2K030T-O	R88M-1AL2K030T-OS2		
		2.6 kW	R88M-1AL2K630T-O	R88M-1AL2K630T-OS2		
	400 VAC	750 W	R88M-1AL75030C-O	R88M-1AL75030C-OS2		
		1 kW	R88M-1AL1K030C-O	R88M-1AL1K030C-OS2		
		1.5 kW	R88M-1AL1K530C-O	R88M-1AL1K530C-OS2		
		2 kW	R88M-1AL2K030C-O	R88M-1AL2K030C-OS2		
		3 kW	R88M-1AL3K030C-O	R88M-1AL3K030C-OS2		
		With brake	200 VAC	200 W	R88M-1AM20030T-BO	R88M-1AM20030T-BOS2
				400 W	R88M-1AM40030T-BO	R88M-1AM40030T-BOS2
750 W	R88M-1AM75030T-BO			R88M-1AM75030T-BOS2		
1 kW	R88M-1AL1K030T-BO			R88M-1AL1K030T-BOS2		
1.5 kW	R88M-1AL1K530T-BO			R88M-1AL1K530T-BOS2		
2 kW	R88M-1AL2K030T-BO			R88M-1AL2K030T-BOS2		
2.6 kW	R88M-1AL2K630T-BO			R88M-1AL2K630T-BOS2		
400 VAC	750 W		R88M-1AL75030C-BO	R88M-1AL75030C-BOS2		
	1 kW		R88M-1AL1K030C-BO	R88M-1AL1K030C-BOS2		
	1.5 kW		R88M-1AL1K530C-BO	R88M-1AL1K530C-BOS2		
	2 kW		R88M-1AL2K030C-BO	R88M-1AL2K030C-BOS2		
	3 kW		R88M-1AL3K030C-BO	R88M-1AL3K030C-BOS2		

AC Servo System 1S-series with Safety Functionality

1,500-r/min Servomotors

Specifications			Model	
			Without oil seal	
			Straight shaft	With key and tap
Without brake	200 VAC	1.5 kW	R88M-1AM1K515T	R88M-1AM1K515T-S2
		2.7 kW	R88M-1AM2K715T	R88M-1AM2K715T-S2
	400 VAC	1.5 kW	R88M-1AM1K515C	R88M-1AM1K515C-S2
		3 kW	R88M-1AM3K015C	R88M-1AM3K015C-S2
With brake	200 VAC	1.5 kW	R88M-1AM1K515T-B	R88M-1AM1K515T-BS2
		2.7 kW	R88M-1AM2K715T-B	R88M-1AM2K715T-BS2
	400 VAC	1.5 kW	R88M-1AM1K515C-B	R88M-1AM1K515C-BS2
		3 kW	R88M-1AM3K015C-B	R88M-1AM3K015C-BS2

Specifications			Model	
			With oil seal	
			Straight shaft	With key and tap
Without brake	200 VAC	1.5 kW	R88M-1AM1K515T-O	R88M-1AM1K515T-OS2
		2.7 kW	R88M-1AM2K715T-O	R88M-1AM2K715T-OS2
	400 VAC	1.5 kW	R88M-1AM1K515C-O	R88M-1AM1K515C-OS2
		3 kW	R88M-1AM3K015C-O	R88M-1AM3K015C-OS2
With brake	200 VAC	1.5 kW	R88M-1AM1K515T-BO	R88M-1AM1K515T-BOS2
		2.7 kW	R88M-1AM2K715T-BO	R88M-1AM2K715T-BOS2
	400 VAC	1.5 kW	R88M-1AM1K515C-BO	R88M-1AM1K515C-BOS2
		3 kW	R88M-1AM3K015C-BO	R88M-1AM3K015C-BOS2

Decelerator (Backlash: 3 Arcminutes Max.)

For 3,000-r/min Servomotors

Servomotor rated output	Reduction ratio	Model (Straight shaft) *
200 W	1/5	R88G-HPG14A05200B□
	1/11	R88G-HPG14A11200B□
	1/21	R88G-HPG20A21200B□
	1/33	R88G-HPG20A33200B□
	1/45	R88G-HPG20A45200B□
400 W	1/5	R88G-HPG14A05400B□
	1/11	R88G-HPG20A11400B□
	1/21	R88G-HPG20A21400B□
	1/33	R88G-HPG32A33400B□
	1/45	R88G-HPG32A45400B□
750 W (200 V)	1/5	R88G-HPG20A05750B□
	1/11	R88G-HPG20A11750B□
	1/21	R88G-HPG32A21750B□
	1/33	R88G-HPG32A33750B□
	1/45	R88G-HPG32A45750B□
750 W (400 V)	1/5	R88G-HPG32A052K0B□
	1/11	R88G-HPG32A112K0B□
	1/21	R88G-HPG32A211K5B□
	1/33	R88G-HPG32A33600SB□

Servomotor rated output	Reduction ratio	Model (Straight shaft) *
1 kW	1/5	R88G-HPG32A052K0B□
	1/11	R88G-HPG32A112K0B□
	1/21	R88G-HPG32A211K5B□
1.5 kW	1/5	R88G-HPG32A052K0B□
	1/11	R88G-HPG32A112K0B□
	1/21	R88G-HPG32A211K5B□
2 kW	1/5	R88G-HPG32A052K0B□
	1/11	R88G-HPG32A112K0B□
2.6 kW (200 V) 3 kW (400 V)	1/5	R88G-HPG32A053K0B□

* The standard shaft type is a straight shaft. A model with a key and tap is indicated with "J" at □ of the Decelerator model number. e.g. R88G-HPG11B05100BJ

AC Servo System 1S-series with Safety Functionality

For 1,500-r/min Servomotors

Servomotor rated output	Reduction ratio	Model (Straight shaft) *
1.5 kW	1/5	R88G-HPG32A053K0B□
	1/11	R88G-HPG32A112K0SB□
	1/21	R88G-HPG50A21900TB□
	1/33	R88G-HPG50A33900TB□
2.7 kW (200 V) 3 kW (400 V)	1/5	R88G-HPG50A055K0SB□
	1/11	R88G-HPG50A115K0SB□
	1/20	R88G-HPG65A205K0SB□
	1/25	R88G-HPG65A255K0SB□

* The standard shaft type is a straight shaft. A model with a key and tap is indicated with "J" at □ of the Decelerator model number. e.g. R88G-HPG11B05100BJ

Decelerator (Backlash: 15 Arcminutes Max.) For 3,000-r/min Servomotors

Servomotor rated output	Reduction ratio	Model
200 W	1/5	R88G-VRXF05B200CJ
	1/9	R88G-VRXF09C200CJ
	1/15	R88G-VRXF15C200CJ
	1/25	R88G-VRXF25C200CJ
400 W	1/5	R88G-VRXF05C400CJ
	1/9	R88G-VRXF09C400CJ
	1/15	R88G-VRXF15C400CJ
	1/25	R88G-VRXF25C400CJ
750 W (200 V)	1/5	R88G-VRXF05C750CJ
	1/9	R88G-VRXF09D750CJ
	1/15	R88G-VRXF15D750CJ
	1/25	R88G-VRXF25D750CJ

Cables and Peripheral Devices

Integrated Cable (Flexible Cable)

Applicable Servomotor			Without brake wire	With brake wire
			Model	Model
200 V	3,000-r/min Servomotors of 200 W, 400 W, 750 W	3 m	R88A-CX1A003SF	R88A-CX1A003BF
		5 m	R88A-CX1A005SF	R88A-CX1A005BF
		10 m	R88A-CX1A010SF	R88A-CX1A010BF
		15 m	R88A-CX1A015SF	R88A-CX1A015BF
		20 m	R88A-CX1A020SF	R88A-CX1A020BF
200 V	3,000-r/min Servomotors of 1 kW	3 m	R88A-CX1B003SF	R88A-CX1B003BF
		5 m	R88A-CX1B005SF	R88A-CX1B005BF
		10 m	R88A-CX1B010SF	R88A-CX1B010BF
		15 m	R88A-CX1B015SF	R88A-CX1B015BF
200 V 400 V	200 V 3,000-r/min Servomotors of 1.5 kW 1,500-r/min Servomotors of 1.5 kW 400 V 3,000-r/min Servomotors of 750 W, 1 kW, 1.5 kW, 2 kW, 3 kW 1,500-r/min Servomotors of 1.5 kW, 3 kW	3 m	R88A-CX1C003SF	R88A-CX1C003BF
		5 m	R88A-CX1C005SF	R88A-CX1C005BF
		10 m	R88A-CX1C010SF	R88A-CX1C010BF
		15 m	R88A-CX1C015SF	R88A-CX1C015BF
		20 m	R88A-CX1C020SF	R88A-CX1C020BF
200 V	3,000-r/min Servomotors of 2 kW, 2.6 kW 1,500-r/min Servomotors of 2.7 kW	3 m	R88A-CX1D003SF	R88A-CX1D003BF
		5 m	R88A-CX1D005SF	R88A-CX1D005BF
		10 m	R88A-CX1D010SF	R88A-CX1D010BF
		15 m	R88A-CX1D015SF	R88A-CX1D015BF
		20 m	R88A-CX1D020SF	R88A-CX1D020BF

Extension Power Cable (Flexible Cable)

Use the cables listed below to extend the integrated cable either with or without brake wire. Also, use R88A-CX1BE□□BF when you use an extension cable for R88A-CX1C□□□□F.





Applicable Servomotor		Model	
200 V	3,000-r/min Servomotors of 200 W, 400 W, 750 W	10 m	R88A-CX1AE10BF
		20 m	R88A-CX1AE20BF
200 V 400 V	200 V 3,000-r/min Servomotors of 1 kW, 1.5 kW 1,500-r/min Servomotors of 1.5 kW 400 V 3,000-r/min Servomotors of 750 W, 1 kW, 1.5 kW, 2 kW, 3 kW 1,500r/min Servomotors of 1.5 kW, 3 kW	10 m	R88A-CX1BE10BF
		20 m	R88A-CX1BE20BF
200 V	3,000-r/min Servomotors of 2 kW, 2.6 kW 1,500-r/min Servomotors of 2.7 kW	10 m	R88A-CX1DE10BF
		20 m	R88A-CX1DE20BF

AC Servo System 1S-series with Safety Functionality

Recommended EtherCAT Communications Cable

Use a straight STP (shielded twisted-pair) cable of category 5 or higher with double shielding (braiding and aluminum foil tape) for EtherCAT.

Cabel with Connectors

Item	Appearance	Recommended manufacturer	Cable length [m]	Model
Cable with Connectors on Both Ends (RJ45/RJ45) Standard RJ45 plugs type *1 Wire gauge and number of pairs: AWG26, 4-pair cable Cable sheath material: LSZH *2 Cable color: Yellow *3		OMRON	0.3	XS6W-6LSZH8SS30CM-Y
			0.5	XS6W-6LSZH8SS50CM-Y
			1	XS6W-6LSZH8SS100CM-Y
			2	XS6W-6LSZH8SS200CM-Y
			3	XS6W-6LSZH8SS300CM-Y
			5	XS6W-6LSZH8SS500CM-Y
Cable with Connectors on Both Ends (RJ45/RJ45) Rugged RJ45 plugs type *1 Wire gauge and number of pairs: AWG22, 2-pair cable Cable color: Light blue		OMRON	0.3	XS5W-T421-AMD-K
			0.5	XS5W-T421-BMD-K
			1	XS5W-T421-CMD-K
			2	XS5W-T421-DMD-K
			5	XS5W-T421-GMD-K
			10	XS5W-T421-JMD-K
Cable with Connectors on Both Ends (M12 Straight/M12 Straight) Shield Strengthening Connector cable *4 M12/Smartclick Connectors Wire Gauge and Number of Pairs: AWG22, 2-pair cable Cable color: Black		OMRON	0.5	XS5W-T421-BM2-SS
			1	XS5W-T421-CM2-SS
			2	XS5W-T421-DM2-SS
			3	XS5W-T421-EM2-SS
			5	XS5W-T421-GM2-SS
			10	XS5W-T421-JM2-SS
Cable with Connectors on Both Ends (M12 Straight/RJ45) Shield Strengthening Connector cable *4 M12/Smartclick Connectors Rugged RJ45 plugs type Wire Gauge and Number of Pairs: AWG22, 2-pair cable Cable color: Black		OMRON	0.5	XS5W-T421-BMC-SS
			1	XS5W-T421-CMC-SS
			2	XS5W-T421-DMC-SS
			3	XS5W-T421-EMC-SS
			5	XS5W-T421-GMC-SS
			10	XS5W-T421-JMC-SS

*1. Standard type cables length 0.2, 0.3, 0.5, 1, 1.5, 2, 3, 5, 7.5, 10, 15 and 20 m are available.

Rugged type cables length 0.3, 0.5, 1, 2, 3, 5, 10 and 15 m are available.

For details, refer to Cat.No.G019.

*2. The lineup features Low Smoke Zero Halogen cables for in-cabinet use and PUR cables for out-of-cabinet use. Although the LSZH cable is single shielded, its communications and noise characteristics meet the standards.

*3. Cables colors are available in blue, yellow, or Green.

*4. For details, contact your OMRON representative.

Cables/Connectors

Wire Gauge and Number of Pairs: AWG24, 4-pair Cable

Item	Appearance	Recommended manufacturer	Model
Cables	---	Hitachi Metals, Ltd.	NETSTAR-C5E SAB 0.5 × 4P CP *
	---	Kuramo Electric Co.	KETH-SB *
RJ45 Connectors	---	Panduit Corporation	MPS588-C *

* We recommend you to use above cable and connector together.

Wire Gauge and Number of Pairs: AWG22, 2-pair Cable

Item	Appearance	Recommended manufacturer	Model
Cables	---	Kuramo Electric Co.	KETH-PSB-OMR *
	---	JMACS Japan Co., Ltd.	PNET/B *
RJ45 Assembly Connector		OMRON	XS6G-T421-1 *

* We recommend you to use above cable and connector together.

AC Servo System 1S-series with Safety Functionality

Peripheral Connector

Servo Drive Side Connectors

One of each of servo drive side connectors (except the encoder connector) are included with the R88D-1SN□-ECT AC Servo Drive. All connectors are also available separately for maintenance.

Name and applications	Model
Main circuit connector (CNA) *1 For R88D-1SAN02H-ECT/ -1SAN04H-ECT/ -1SAN08H-ECT/ -1SAN10H-ECT	R88A-CN102P *4
Main circuit connector A (CNA) *2 For R88D-1SAN15H-ECT/ -1SAN20H-ECT/ -1SAN30H-ECT/ -1SAN10F-ECT/-1SAN15F-ECT/ -1SAN20F-ECT/ -1SAN30F-ECT	R88A-CN103P *4
Main circuit connector B (CNB) *2 For R88D-1SAN15H-ECT/ -1SAN20H-ECT/ -1SAN30H-ECT/ -1SAN10F-ECT/-1SAN15F-ECT/ -1SAN20F-ECT/ -1SAN30F-ECT	R88A-CN104P *4
Motor connector (CNC) For R88D-1SAN02H-ECT/ -1SAN04H-ECT/ -1SAN08H-ECT/ -1SAN10H-ECT	R88A-CN101A *4
Motor connector (CNC) For R88D-1SAN15H-ECT/ -1SAN20H-ECT/ -1SAN30H-ECT/ -1SAN10F-ECT/-1SAN15F-ECT/ -1SAN20F-ECT/ -1SAN30F-ECT	R88A-CN102A *4
Control power supply connector (CND) For R88D-1SAN15H-ECT/ -1SAN20H-ECT/ -1SAN30H-ECT/ -1SAN10F-ECT/-1SAN15F-ECT/ -1SAN20F-ECT/ -1SAN30F-ECT	R88A-CN101P *4
Control I/O connector (CN1)	R88A-CN102C
Encoder connector (CN2)	R88A-CN101R
Brake interlock connector (CN12)	R88A-CN101B
Safety signal connector (CN14) *3	R88A-CN101S
Safe brake control connector (CN15)	R88A-CN102S

*1. Two short-circuit wires are connected to the connector.

*2. One short-circuit wire is connected to the connector.

*3. Four short-circuit wires are connected to the connector. One pin to prevent improper wiring are included.

*4. One opener is included.

AC Servo System 1S-series with Safety Functionality

Shield Clamp Bracket

A shield clamp is used to fix the integrated cable and to connect the shield of the integrated cable to FG of the servo drive. The shield clamp consists of the shield clamp bracket and shield clamp plate.

Name	Applicable Servo Drive and Integrated Cables	Model
Shield Clamp Bracket S	R88D-1SAN02H-ECT R88D-1SAN04H-ECT R88D-1SAN08H-ECT	R88A-CX1A□□□□F
	R88D-1SAN10H-ECT	R88A-CX1B□□□□F
	R88D-1SAN15H-ECT R88D-1SAN10F-ECT R88D-1SAN15F-ECT R88D-1SAN20F-ECT R88D-1SAN30F-ECT	R88A-CX1C□□□□F
	R88D-1SAN20H-ECT R88D-1SAN30H-ECT	R88A-CX1D□□□□F
		R88A-SC10CX

Note: An applicable Integrated cable comes with a shield clamp bracket.
An extension cable does not come with a shield clamp bracket.

External Regeneration Resistors

Applicable Servo Drive	Specifications	Model
R88D-1SAN02H-ECT	Regeneration process capacity: 24 W, 25 Ω	R88A-RR12025
R88D-1SAN30H-ECT	Regeneration process capacity: 60 W, 8 Ω	R88A-RR30008
R88D-1SAN20H-ECT	Regeneration process capacity: 60 W, 10 Ω	R88A-RR30010
R88D-1SAN15H-ECT	Regeneration process capacity: 60 W, 14 Ω	R88A-RR30014
R88D-1SAN08H-ECT/-1SAN10H-ECT/-1SAN20F-ECT *	Regeneration process capacity: 60 W, 20 Ω	R88A-RR30020
R88D-1SAN02H-ECT/-1SAN04H-ECT	Regeneration process capacity: 60 W, 25 Ω	R88A-RR30025
R88D-1SAN30F-ECT	Regeneration process capacity: 60 W, 32 Ω	R88A-RR30032
R88D-1SAN10F-ECT *	Regeneration process capacity: 60 W, 33 Ω	R88A-RR30033
R88D-1SAN15F-ECT	Regeneration process capacity: 60 W, 54 Ω	R88A-RR30054

* Use two series-connected External Regeneration Resistors for this model.

External Regeneration Resistance Unit

Applicable Servo Drive	Specifications	Model
R88D-1SAN30H-ECT	Regeneration process capacity: 640 W, 8 Ω	R88A-RR1K608
R88D-1SAN20H-ECT	Regeneration process capacity: 640 W, 10 Ω	R88A-RR1K610
R88D-1SAN15H-ECT	Regeneration process capacity: 640 W, 14 Ω	R88A-RR1K614
R88D-1SAN08H-ECT/-1SAN10H-ECT/-1SAN20F-ECT *	Regeneration process capacity: 640 W, 20 Ω	R88A-RR1K620
R88D-1SAN30F-ECT	Regeneration process capacity: 640 W, 32 Ω	R88A-RR1K632
R88D-1SAN20F-ECT	Regeneration process capacity: 640 W, 40 Ω	R88A-RR1K640
R88D-1SAN15F-ECT	Regeneration process capacity: 640 W, 54 Ω	R88A-RR1K654
R88D-1SAN10F-ECT	Regeneration process capacity: 640 W, 66 Ω	R88A-RR1K666

* Use two series-connected External Regeneration Resistors for this model.

DC Reactor

Applicable Servo Drive	Model
R88D-1SAN02H-ECT	R88A-PD2002
R88D-1SAN04H-ECT	R88A-PD2004
R88D-1SAN08H-ECT	R88A-PD2007
R88D-1SAN10H-ECT/ -1SAN15H-ECT	R88A-PD2015
R88D-1SAN20H-ECT	R88A-PD2022
R88D-1SAN30H-ECT	R88A-PD2037
R88D-1SAN10F-ECT/ -1SAN15F-ECT	R88A-PD4015
R88D-1SAN20F-ECT	R88A-PD4022
R88D-1SAN30F-ECT	R88A-PD4037

AC Servo System 1S-series with Safety Functionality

Software

Automation Software Sysmac Studio

Please purchase a DVD and required number of licenses the first time you purchase the Sysmac Studio. DVDs and licenses are available individually. Each model of licenses does not include any DVD.

Product name	Specifications	Number of licenses	Media	Model
Sysmac Studio Standard Edition Ver.1.□□ *1	The Sysmac Studio is the software that provides an integrated environment for setting, programming, debugging and maintenance of machine automation controllers including the NJ/NX-series CPU Units, NY-series Industrial PC, EtherCat Slave, and the HMI.	--- (Media only)	Sysmac Studio (32 bit) DVD	SYSMAC-SE200D
	Sysmac Studio runs on the following OS. *2 Windows 7 (32-bit/64-bit version)/Windows 8 (32-bit/64-bit version)/ Windows 8.1 (32-bit/64-bit version)/Windows 10 (32-bit/64-bit version)/ Windows 11 (64-bit version)	--- (Media only)	Sysmac Studio (64 bit) DVD	SYSMAC-SE200D-64
	The Sysmac Studio Standard Edition DVD includes Support Software to set up EtherNet/IP Units, DeviceNet slaves, Serial Communications Units, and Support Software for creating screens on HMIs (CX-Designer). For details, refer to your OMRON website.	1 license *3	---	SYSMAC-SE201L
Sysmac Studio Drive Edition Ver.1.□□	Sysmac Studio Drive Edition is a limited license that provides selected functions required for 1S/G5 series Servo settings. This product is a license only. You need the Sysmac Studio Standard Edition DVD media to install it. With Drive Edition, you can use only the setup functions for 1S, G5-series Servo System	1 license	---	SYSMAC-DE001L

*1 The 1S-series Safety Servo Drive unit version 1.0 or later is supported by Sysmac Studio version 1.44.1 or higher.

*2 Model "SYSMAC-SE200D-64" runs on Windows 10 (64 bit) or higher.

*3 Multi licenses are available for the Sysmac Studio (3, 10, 30, or 50 licenses).

Collections of software functional components

Sysmac Library

Sysmac Library is POU Libraries (Function Block and Function) provided for NJ/NX-series Controller.

Please download it from following URL and install to Sysmac Studio.

http://www.ia.omron.com/sysmac_library/

Product	Features	Model
EtherCAT 1S Series Library	The EtherCAT 1S Series Library is used to initialize the absolute encoder, back up and restore the parameters for an OMRON 1S-series Servo Drive with built-in EtherCAT communications. You can use this library to reduce manpower of programming when implementing the processing for a Servo Drive.	SYSMAC-XR011

Combination table

Servo Drive and Servomotor Combinations

The following tables show the possible combinations of 1S-series Servo Drives Advance type and Servomotors.

The Servomotors and Servo Drives can only be used in the listed combinations. "□" at the end of the motor model number is for options, such as the shaft type and brake.

3,000-r/min Servomotors and Servo Drives

Main circuit power supply voltage	Servomotor rated output	Servomotor	Servo Drive
Single-phase/3-phase 200 VAC	200 W	R88M-1AM20030T-□	R88D-1SAN02H-ECT
	400 W	R88M-1AM40030T-□	R88D-1SAN04H-ECT
	750 W	R88M-1AM75030T-□	R88D-1SAN08H-ECT
	1.5 kW	R88M-1AL1K530T-□	R88D-1SAN15H-ECT
3-phase 200 VAC	1 kW	R88M-1AL1K030T-□	R88D-1SAN10H-ECT
	2 kW	R88M-1AL2K030T-□	R88D-1SAN20H-ECT
	2.6 kW	R88M-1AL2K630T-□	R88D-1SAN30H-ECT
3-phase 400 VAC	750 W	R88M-1AL75030C-□	R88D-1SAN10F-ECT
	1 kW	R88M-1AL1K030C-□	R88D-1SAN10F-ECT
	1.5 kW	R88M-1AL1K530C-□	R88D-1SAN15F-ECT
	2 kW	R88M-1AL2K030C-□	R88D-1SAN20F-ECT
	3 kW	R88M-1AL3K030C-□	R88D-1SAN30F-ECT

AC Servo System 1S-series with Safety Functionality

1,500-r/min Servomotors and Servo Drives

Main circuit power supply voltage	Servomotor rated output	Servomotor	Servo Drive
Single-phase/3-phase 200 VAC	1.5 kW	R88M-1AM1K515T-□	R88D-1SAN15H-ECT
3-phase 200 VAC	2.7 kW	R88M-1AM2K715T-□	R88D-1SAN30H-ECT
3-phase 400 VAC	1.5 kW	R88M-1AM1K515C-□	R88D-1SAN15F-ECT
	3 kW	R88M-1AM3K015C-□	R88D-1SAN30F-ECT

Servomotor and Decelerator Combinations

The following tables show the possible combinations of 1S-series Servomotors Advance type and Decelerators. You cannot use a Servomotor with a key and tap (model numbers with -S2 at the end) in combination with a Decelerator.

Backlash: 3 Arcminutes Max.

Servomotor 3,000 r/min and Decelerator Combination Table

Reduction ratio	1/5	1/11	1/21	1/33	1/45
R88M-1AM20030□	R88G-HPG 14A05200B□	R88G-HPG 14A11200B□	R88G-HPG 20A21200B□	R88G-HPG 20A33200B□	R88G-HPG 20A45200B□
R88M-1AM40030□	R88G-HPG 14A05400B□	R88G-HPG 20A11400B□	R88G-HPG 20A21400B□	R88G-HPG 32A33400B□	R88G-HPG 32A45400B□
R88M-1AM75030□ (200 VAC)	R88G-HPG 20A05750B□	R88G-HPG 20A11750B□	R88G-HPG 32A21750B□	R88G-HPG 32A33750B□	R88G-HPG 32A45750B□
R88M-1AL75030□ (400 VAC)	R88G-HPG 32A052K0B□	R88G-HPG 32A112K0B□	R88G-HPG 32A211K5B□	R88G-HPG 32A33600SB□	---
R88M-1AL1K030□					
R88M-1AL1K530□					
R88M-1AL2K030□	R88G-HPG 32A053K0B□	---	---	---	---
R88M-1AL2K630□ (200 VAC)					
R88M-1AL3K030□ (400 VAC)					

Servomotor 1,500 r/min and Decelerator Combination Table

Reduction ratio	1/5	1/11	1/21	1/25	1/33	1/45
R88M-1AM1K515□	R88G-HPG 32A053K0B□	R88G-HPG 32A112K0SB□	---	R88G-HPG 50A21900TB□	---	R88G-HPG 50A33900TB□
R88M-1AM2K715□ (200 VAC)	R88G-HPG 50A055K0SB□	R88G-HPG 50A115K0SB□	R88G-HPG 65A205K0SB□	---	R88G-HPG 65A255K0SB□	---
R88M-1AM3K015□ (400 VAC)						

Backlash: 15 Arcminutes Max.

Servomotor 3,000 r/min and Decelerator Combination Table

Reduction ratio	1/5	1/9	1/15	1/25
R88M-1AM20030□	R88G-VRXF 05B200CJ	R88G-VRXF 09C200CJ	R88G-VRXF 15C200CJ	R88G-VRXF 25C200CJ
R88M-1AM40030□	R88G-VRXF 05C400CJ	R88G-VRXF 09C400CJ	R88G-VRXF 15C400CJ	R88G-VRXF 25C400CJ
R88M-1AM75030□ (200 VAC)	R88G-VRXF 05C750CJ	R88G-VRXF 09D750CJ	R88G-VRXF 15D750CJ	R88G-VRXF 25D750CJ

AC Servo System 1S-series with Safety Functionality

Cable Connection Configuration

Select an appropriate cable for the Servomotor.

Precautions for Correct Use

The regulations for cables differ according to the country in use. (The regulations can also be different in the same country according to the region or where the Servomotors are installed.) Therefore, be sure to check to the respective certificate institution for a cable that conforms to the regulations of each country.

Cables without Brake Wire

Connected to	Model	Connection configuration and external dimensions [mm]	
200 V: 3,000-r/min Servomotors of 200 W, 400 W, and 750 W	R88A-CX1A□□□SF The empty boxes in the model number are for the cable length. (11.9 mm dia.)	Servo Drive side Connector model: Receptacle 3E206-0100KV (3M) Shell kit 3E306-3200-008 (3M)	
200 V: 3,000-r/min Servomotors of 1 kW	R88A-CX1B□□□SF The empty boxes in the model number are for the cable length. (14.5 mm dia.)	Servo Drive side Connector model: Receptacle 3E206-0100KV (3M) Shell kit 3E306-3200-008 (3M)	
200 V: 3,000-r/min Servomotors of 1.5 kW 1,500-r/min Servomotors of 1.5 kW 400 V: 3,000-r/min Servomotors of 750 W, 1 kW, 1.5 kW, 2 kW, and 3 kW 1,500-r/min Servomotors of 1.5 kW and 3 kW	R88A-CX1C□□□SF The empty boxes in the model number are for the cable length. (14.5 mm dia.)	Servo Drive side Connector model: Receptacle 3E206-0100KV (3M) Shell kit 3E306-3200-008 (3M)	
200 V: 3,000-r/min Servomotors of 2 kW and 2.6 kW 1,500-r/min Servomotors of 2.7 kW	R88A-CX1D□□□SF The empty boxes in the model number are for the cable length. (14.9 mm dia.)	Servo Drive side Connector model: Receptacle 3E206-0100KV (3M) Shell kit 3E306-3200-008 (3M)	

Note: Cable length: 3 m, 5 m, 10 m, 15 m, 20 m

The empty boxes in the model number are put as follows: 3 m = 003, 5 m = 005, 10 m = 010.

AC Servo System 1S-series with Safety Functionality

Cables with Brake Wire

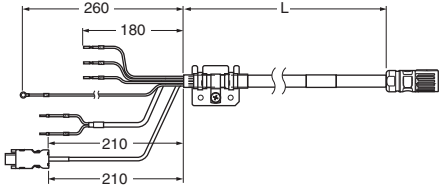
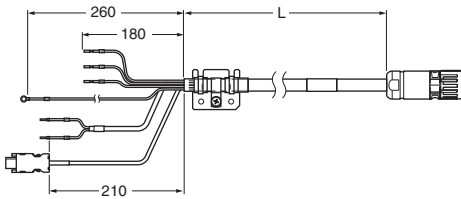
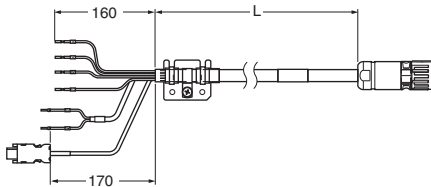
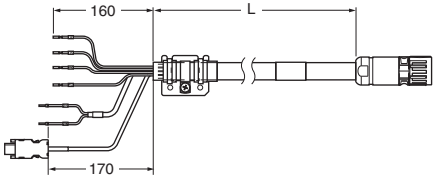
Connected to	Model	Connection configuration and external dimensions [mm]	
200 V: 3,000-r/min Servomotors of 200 W, 400 W, and 750 W	R88A-CX1A□□□BF The empty boxes in the model number are for the cable length. (11.8 mm dia.)	Servo Drive side Connector model: Receptacle 3E206-0100KV (3M) Shell kit 3E306-3200-008 (3M)	 <p>Servomotor side M17 Series (Phoenix Contact) Connector model 1624639 Contact model Power: 1618251 Brake: 1607582 Encoder (DSL): 1607581 Encoder (DSL) shield: 1607582</p>
200 V: 3,000-r/min Servomotors of 1 kW	R88A-CX1B□□□BF The empty boxes in the model number are for the cable length. (14.5 mm dia.)	Servo Drive side Connector model: Receptacle 3E206-0100KV (3M) Shell kit 3E306-3200-008 (3M)	 <p>Servomotor side M23 Series (Phoenix Contact) Connector model 1621517 Contact model Power: 1621576 Brake: 1618251 Encoder (DSL): 1621573</p>
200 V: 3,000-r/min Servomotors of 1.5 kW 1,500-r/min Servomotors of 1.5 kW 400 V: 3,000-r/min Servomotors of 750 W, 1 kW, 1.5 kW, 2 kW, and 3 kW 1,500-r/min Servomotors of 1.5 kW and 3 kW	R88A-CX1C□□□BF The empty boxes in the model number are for the cable length. (14.5 mm dia.)	Servo Drive side Connector model: Receptacle 3E206-0100KV (3M) Shell kit 3E306-3200-008 (3M)	 <p>Servomotor side M23 Series (Phoenix Contact) Connector model 1621517 Contact model Power: 1621576 Brake: 1618251 Encoder (DSL): 1621573</p>
200 V: 3,000-r/min Servomotors of 2 kW and 2.6 kW 1,500-r/min Servomotors of 2.7 kW	R88A-CX1D□□□BF The empty boxes in the model number are for the cable length. (14.9 mm dia.)	Servo Drive side Connector model: Receptacle 3E206-0100KV (3M) Shell kit 3E306-3200-008 (3M)	 <p>Servomotor side M23 Series (Phoenix Contact) Connector model 1621517 Contact model Power: 1621577 Brake: 1618251 Encoder (DSL): 1621573</p>

Note: Cable length: 3 m, 5 m, 10 m, 15 m, 20 m

The empty boxes in the model number are put as follows: 3 m = 003, 5 m = 005, 10 m = 010.

AC Servo System 1S-series with Safety Functionality

Extension Power Cable

Connected to	Model	Connection configuration and external dimensions [mm]	
200 V: 3,000-r/min Servomotors of 200 W, 400 W and 750 W	R88A-CX1AE□□BF The empty boxes in the model number are for the cable length. (11.8 mm dia.)	Servo Drive side connector M17 Series (Phoenix Contact) Connector model 1624653 Contact model Power: 1618256 Brake: 1607579 Encoder (DSL): 1607578 Encoder (DSL) shield: 1607579	Servomotor side M17 Series (Phoenix Contact) Connector model 1624639 Contact model Power: 1618251 Brake: 1607582 Encoder (DSL): 1607581 Encoder (DSL) shield: 1607582
200 V: 3,000-r/min Servomotors of 1 kW and 1.5 kW 1,500-r/min Servomotors of 1.5 kW 400 V: 3,000-r/min Servomotors of 750 W, 1 kW, 1.5 kW, 2 kW and 3 kW 1,500-r/min Servomotors of 1.5 kW and 3 kW	R88A-CX1BE□□BF The empty boxes in the model number are for the cable length. (14.5 mm dia.)	Servo Drive side connector M23 Series (Phoenix Contact) Connector model 1621549 Contact model Power: 1621579 Brake: 1618256 Encoder (DSL): 1621575	Servomotor side M23 Series (Phoenix Contact) Connector model 1621517 Contact model Power: 1621576 Brake: 1618251 Encoder (DSL): 1621573
200 V: 3,000-r/min Servomotors of 2 kW and 2.6 kW 1,500-r/min Servomotors of 2.7 kW	R88A-CX1DE□□BF The empty boxes in the model number are for the cable length. (14.9 mm dia.)	Servo Drive side connector M23 Series (Phoenix Contact) Connector model 1621549 Contact model Power: 1621580 Brake: 1618256 Encoder (DSL): 1621575	Servomotor side M23 Series (Phoenix Contact) Connector model 1621517 Contact model Power: 1621577 Brake: 1618251 Encoder (DSL): 1621573

Note: Cable length: 10 m, 20 m

The empty boxes in the model number are put as follows: 10 m = 10, 20 m = 20

Combinations of Integrated Cables and Extension Power Cables

The table below lists the combinations of cables that can be used to extend the integrated cable to more than 20 m.

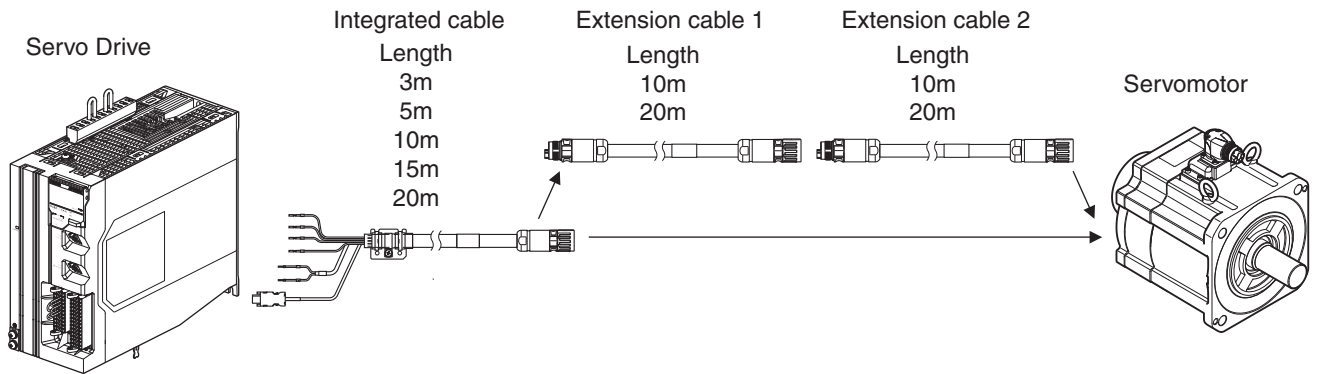

Total	Length (m)			Combination
	Integrated cable	Extension cable 1	Extension cable 2	
3	3	---	---	Integrated cable only
5	5	---	---	Integrated cable only
10	10	---	---	Integrated cable only
15	15	---	---	Integrated cable only
20	20	---	---	Integrated cable only
30	20	10	---	Integrated cable + extension cable 1
40	20	20	---	Integrated cable + extension cable 1
50	20	10	20	Integrated cable + extension cable 1 + extension cable 2 *

* A 20 m extension cable 1 and a 10 m extension cable 2 can also be used.

AC Servo System 1S-series with Safety Functionality

Related Manuals

English Man. No.	Japanese Man. No.	Model	Manual name
I621	SBCE-438	R88M-1A□□□/ R88D-1SAN□-ECT	AC Servomotors/Servo Drives 1S-series with Built-in EtherCAT Communications and Safety Functionality User's Manual
W535	SBCA-418	NX701-□□□□	NX-series CPU Unit User's Manual (Hardware)
W593	SBCA-462	NX102-□□□□	NX-series NX102 CPU Unit Hardware User's Manual
W578	SBCA-448	NX1P2-□□□□□□ NX1P2-□□□□□□1	NX-series NX1P2 CPU Unit User's Manual (Hardware)
W500	SBCA-466	NJ501-□□□□ NJ301-□□□□ NJ101-□□□□	NJ-series CPU Unit User's Manual (Hardware)
W501	SBCA-467	NX701-□□□□ NX102-□□□□ NX1P2-□□□□ NJ501-□□□□ NJ301-□□□□ NJ101-□□□□	NJ-series / NX-series CPU Unit User's Manual (Software)
W507	SBCE-433	NX701-□□□□ NX102-□□□□ NX1P2-□□□□ NJ501-□□□□ NJ301-□□□□ NJ101-□□□□	NJ-series / NX-series CPU Unit User's Manual (Motion Control)
W505	SBCD-376	NX701-1□□□ NX102-□□□□ NX1P2-□□□□□□ NJ501-□□□□ NJ301-1□□□ NJ101-10□□/90□□	NJ/NX-series CPU Unit Built-in EtherCAT® Port User's Manual
W556	SBCA-434	NY512-□□□□	NY-series IPC Machine Controller Industrial Box PC Hardware User's Manual
W557	SBCA-435	NY532-□□□□	NY-series IPC Machine Controller Industrial Panel PC Hardware User's Manual
W558	SBCA-436	NY532-□□□□ NY512-□□□□	NY-series IPC Machine Controller Industrial Panel PC / Industrial Box PC Software User's Manual
W559	SBCE-379	NY532-□□□□ NY512-□□□□	NY-series IPC Machine Controller Industrial Panel PC / Industrial Box PC Motion Control User's Manual
Z930	SGFM-710	NX-SL□□□□ NX-SI□□□□ NX-SO□□□□	NX-series Safety Control Unit User's Manual
Z931	SGFM-711	NX-SL□□□□	NX-series Safety Control Unit Instructions Reference Manual
W504	SBCA-470	SYSMAC-SE2□□□	Sysmac Studio Version 1 Operation Manual
I589	SBCE-401	SYSMAC-SE2□□□	Sysmac Studio Drive Function Operation Manual
W487	SBCE-359	CJ1W-NC281 CJ1W-NC481 CJ1W-NC881 CJ1W-NCF81 CJ1W-NC482 CJ1W-NC882 CJ1W-NCF82	CJ-series Position Control Unit Operation Manual
Z922	SJLB-306	G9SP-N10S G9SP-N10D G9SP-N20S	G9SP Series Safety Controller Operation Manual

Sizing Tool for AC Servo Motors

AC Servo motors selection for the entire machine

- User can size all axes in one project with the corresponded Sysmac controller.
- Pre-defined system can be used for common applications.
- Selection of optimized drive, motor and gearbox combination.
- Multiple views are not required: design, adjust and validate at a glance.
- Import sizing file directly to Sysmac Studio for reducing the machine development time.

Quick sizing and selection of AC servo motors

- High variety of mechanical system
- Import CAM from Sysmac Studio
- Kinematics chain architecture includes motor, reducer, loads and motion profile.
- Adjustments can be done in one view and results auto-refreshed.

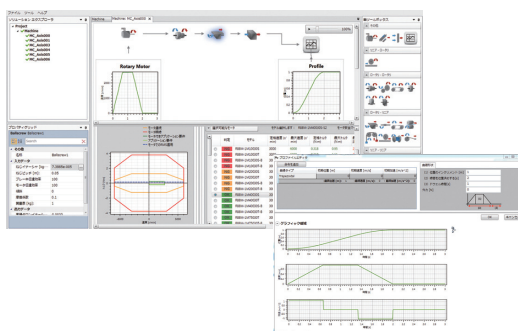

Re-use work done during design phase

- Export sizing file result.
- Import sizing file result in Sysmac Studio.
- EtherCAT configuration, axes settings and drives parameters will be created automatically

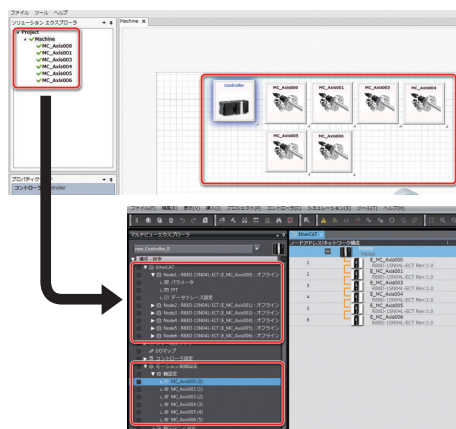

Compatible models

1S series	EtherCAT Communications and Safety Functionality	R88D-1SAN□-ECT
1S series	EtherCAT Communications	R88D-1SN□-ECT
G5 series	EtherCAT Communications for Position Control	R88D-KN□-ECT
G5 series	EtherCAT Communications (Linear Motor Type)	R88D-KN□-ECT-L
G5 series	MECHATROLINK-II Communications	R88D-KN□-ML2
G5 series	General-purpose Pulse Train or Analog Inputs	R88D-KT
G series	MECHATROLINK-II Communications	R88D-GN□-ML2
G series	General-purpose Pulse Train or Analog Inputs	R88D-GT

Sysmac is a trademark or registered trademark of OMRON Corporation in Japan and other countries for OMRON factory automation products. Windows is either registered trademarks or trademarks of Microsoft Corporation in the United States and/or other countries. EtherCAT® and Safety over EtherCAT® are registered trademarks and patented technologies, licensed by Beckhoff Automation GmbH, Germany. EtherNet/IP™ and DeviceNet™ are trademarks of ODVA. Other company names and product names in this document are the trademarks or registered trademarks of their respective companies. The product photographs and figures that are used in this catalog may vary somewhat from the actual products. Microsoft product screen shot(s) reprinted with permission from Microsoft Corporation.

Terms and Conditions Agreement

Read and understand this catalog.

Please read and understand this catalog before purchasing the products. Please consult your OMRON representative if you have any questions or comments.

Warranties.

- (a) Exclusive Warranty. Omron's exclusive warranty is that the Products will be free from defects in materials and workmanship for a period of twelve months from the date of sale by Omron (or such other period expressed in writing by Omron). Omron disclaims all other warranties, express or implied.
- (b) Limitations. OMRON MAKES NO WARRANTY OR REPRESENTATION, EXPRESS OR IMPLIED, ABOUT NON-INFRINGEMENT, MERCHANTABILITY OR FITNESS FOR A PARTICULAR PURPOSE OF THE PRODUCTS. BUYER ACKNOWLEDGES THAT IT ALONE HAS DETERMINED THAT THE PRODUCTS WILL SUITABLY MEET THE REQUIREMENTS OF THEIR INTENDED USE.

Omron further disclaims all warranties and responsibility of any type for claims or expenses based on infringement by the Products or otherwise of any intellectual property right. (c) Buyer Remedy. Omron's sole obligation hereunder shall be, at Omron's election, to (i) replace (in the form originally shipped with Buyer responsible for labor charges for removal or replacement thereof) the non-complying Product, (ii) repair the non-complying Product, or (iii) repay or credit Buyer an amount equal to the purchase price of the non-complying Product; provided that in no event shall Omron be responsible for warranty, repair, indemnity or any other claims or expenses regarding the Products unless Omron's analysis confirms that the Products were properly handled, stored, installed and maintained and not subject to contamination, abuse, misuse or inappropriate modification. Return of any Products by Buyer must be approved in writing by Omron before shipment. Omron Companies shall not be liable for the suitability or unsuitability or the results from the use of Products in combination with any electrical or electronic components, circuits, system assemblies or any other materials or substances or environments. Any advice, recommendations or information given orally or in writing, are not to be construed as an amendment or addition to the above warranty.

See <http://www.omron.com/global/> or contact your Omron representative for published information.

Limitation on Liability; Etc.

OMRON COMPANIES SHALL NOT BE LIABLE FOR SPECIAL, INDIRECT, INCIDENTAL, OR CONSEQUENTIAL DAMAGES, LOSS OF PROFITS OR PRODUCTION OR COMMERCIAL LOSS IN ANY WAY CONNECTED WITH THE PRODUCTS, WHETHER SUCH CLAIM IS BASED IN CONTRACT, WARRANTY, NEGLIGENCE OR STRICT LIABILITY.

Further, in no event shall liability of Omron Companies exceed the individual price of the Product on which liability is asserted.

Suitability of Use.

Omron Companies shall not be responsible for conformity with any standards, codes or regulations which apply to the combination of the Product in the Buyer's application or use of the Product. At Buyer's request, Omron will provide applicable third party certification documents identifying ratings and limitations of use which apply to the Product. This information by itself is not sufficient for a complete determination of the suitability of the Product in combination with the end product, machine, system, or other application or use. Buyer shall be solely responsible for determining appropriateness of the particular Product with respect to Buyer's application, product or system. Buyer shall take application responsibility in all cases.

NEVER USE THE PRODUCT FOR AN APPLICATION INVOLVING SERIOUS RISK TO LIFE OR PROPERTY OR IN LARGE QUANTITIES WITHOUT ENSURING THAT THE SYSTEM AS A WHOLE HAS BEEN DESIGNED TO ADDRESS THE RISKS, AND THAT THE OMRON PRODUCT(S) IS PROPERLY RATED AND INSTALLED FOR THE INTENDED USE WITHIN THE OVERALL EQUIPMENT OR SYSTEM.

Programmable Products.

Omron Companies shall not be responsible for the user's programming of a programmable Product, or any consequence thereof.

Performance Data.

Data presented in Omron Company websites, catalogs and other materials is provided as a guide for the user in determining suitability and does not constitute a warranty. It may represent the result of Omron's test conditions, and the user must correlate it to actual application requirements. Actual performance is subject to the Omron's Warranty and Limitations of Liability.

Change in Specifications.

Product specifications and accessories may be changed at any time based on improvements and other reasons. It is our practice to change part numbers when published ratings or features are changed, or when significant construction changes are made. However, some specifications of the Product may be changed without any notice. When in doubt, special part numbers may be assigned to fix or establish key specifications for your application. Please consult with your Omron's representative at any time to confirm actual specifications of purchased Product.

Errors and Omissions.

Information presented by Omron Companies has been checked and is believed to be accurate; however, no responsibility is assumed for clerical, typographical or proofreading errors or omissions.

Note: Do not use this document to operate the Unit.

OMRON Corporation Industrial Automation Company
Kyoto, JAPAN

Contact: www.ia.omron.com

Regional Headquarters

OMRON EUROPE B.V.

Wegalaan 67-69, 2132 JD Hoofddorp
The Netherlands
Tel: (31)2356-81-300/Fax: (31)2356-81-388

OMRON ELECTRONICS LLC

2895 Greenspoint Parkway, Suite 200
Hoffman Estates, IL 60169 U.S.A.
Tel: (1) 847-843-7900/Fax: (1) 847-843-7787

OMRON ASIA PACIFIC PTE. LTD.

438B Alexandra Road, #08-01/02 Alexandra
Technopark, Singapore 119968
Tel: (65) 6835-3011/Fax: (65) 6835-2711

OMRON (CHINA) CO., LTD.

Room 2211, Bank of China Tower,
200 Yin Cheng Zhong Road,
PuDong New Area, Shanghai, 200120, China
Tel: (86) 21-5037-2222/Fax: (86) 21-5037-2200

Authorized Distributor:

© OMRON Corporation 2020-2022 All Rights Reserved.
In the interest of product improvement,
specifications are subject to change without notice.

CSM_2_5

Cat. No. I842-E1-06

0522 (0920)