

Reliable detection of difficult workpieces helps reduce line commissioning time and contributes to better facility "operation rates".



# E3AS Series changes the “way of using” reflective photoelectric sensors

Production lines have become more advanced and complex, and skilled production workers are hard to come by. In order to increase equipment design flexibility and reduce sensor installation time, there is a growing need for reflective photoelectric sensors that require no receivers or reflectors. OMRON’s E3AS Series offers new ways of using reflective photoelectric sensors to reduce line commissioning time and increases uptime,



TOF Laser Sensor  
E3AS-F

CMOS Laser Sensor  
E3AS-HL

## Curved, glossy, or irregular surfaces can be detected



Design, Commissioning

Reliable detection of difficult workpieces reduces equipment design and commissioning time ..... P.4

## Versatile installation allows flexible design

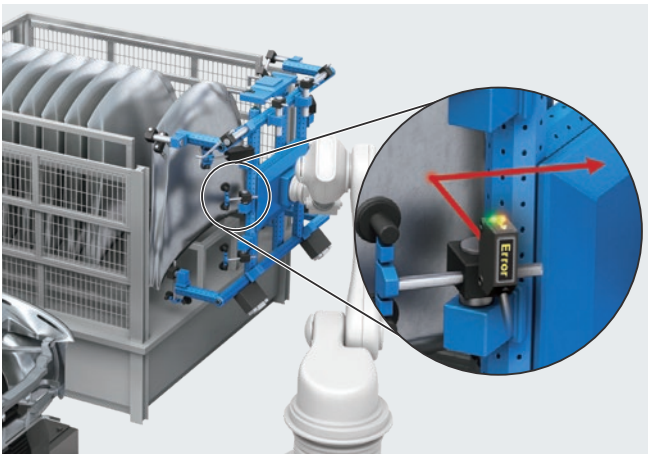

Design, Commissioning

Flexible installation saves design time ..... P.6

## Antifouling coated sensing surface reduces false detections



Mass production

Antifouling coating on sensing surface ensures stable operation even in harsh environments ..... P.8

# Reliable detection of difficult workpieces reduces equipment design

When difficult-to-detect workpieces (curved, glossy, or casting surfaces) cannot be detected correctly, sensors need to be reselected or adjusted. The E3AS Series provides reliable detection with less effect of curved, glossy, or casting surfaces, reducing design and commissioning time.

## E3AS-HL for workpieces with curved or irregular surfaces and glossy workpieces

### Reliable detection of metal workpieces with curved or irregular surfaces



With spot beam, detection is unstable since the reflected light does not reach the sensor depending on the profile of the surface.

With the line beam of the E3AS-HL Sensor, detection is less affected by the profile of the surface since the reflected light reaches the sensor from any part of the surface. Glossy objects such as oily metal workpieces also hardly affect detection.

### Reliable detection of various colored or glossy workpieces

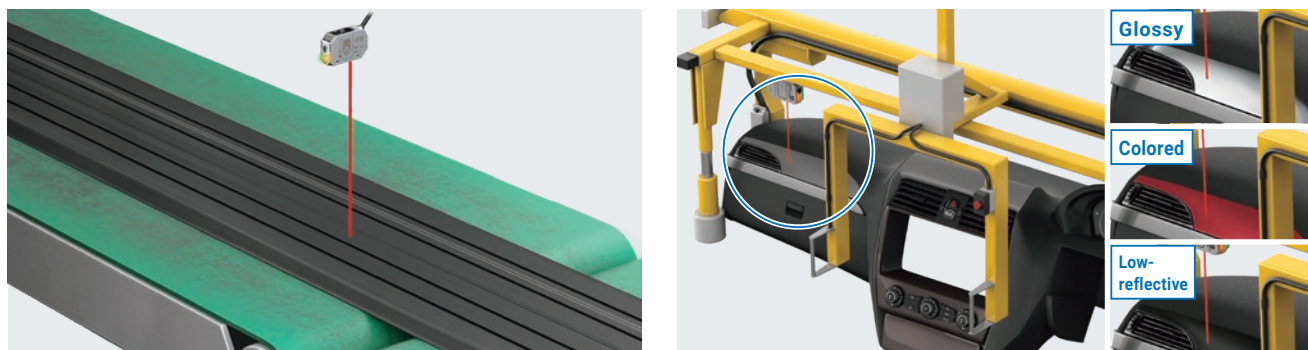

Level differences between low-reflective thin workpieces and the background sometimes cannot be detected. E3AS-HL Sensors, hardly affected by material type or color, can detect level differences.

Detection is prone to be unstable because the sensing distance varies depending on the workpiece material and color. E3AS-HL Sensors, hardly affected by material type or color, requires no adjustment for each workpiece.

## CMOS sensing with built-in lens alignment technology minimizes the influence of material properties

**PATENT PENDING** \*1

**From** Material properties greatly affect the detection due to blurred received light spot on CMOS as a result of low position adjustment accuracy of the receiver lens.

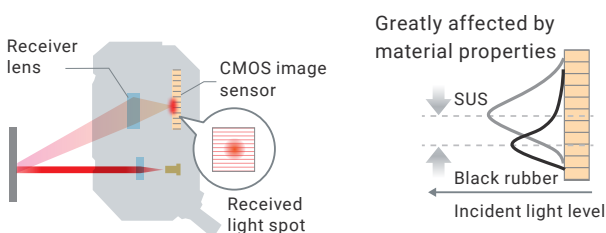

**To** Material properties hardly affect the detection since the receiver lens position is automatically adjusted to the micrometer level to minimize the received light spot.

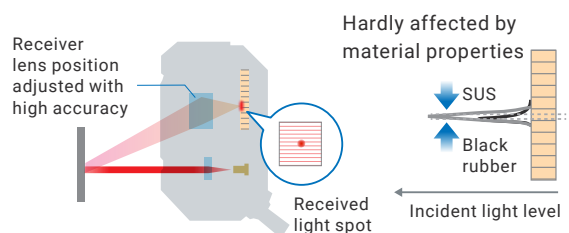

# and commissioning time

## E3AS-F for large workpieces with various colors or rough surfaces

### Reliable detection of metal workpieces with rough surfaces

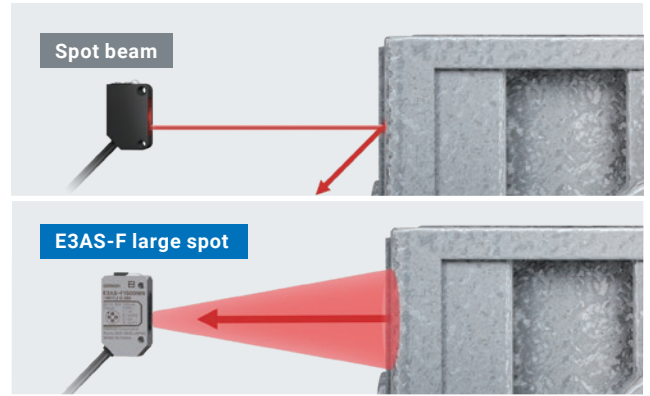
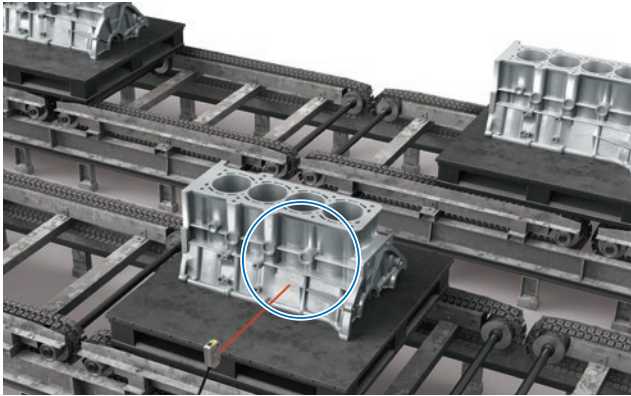

With spot beam, detection is unstable since the reflected light does not reach the sensor depending on the profile of the workpiece surface. With the large spot of the E3AS-F Sensor, detection is less affected by the surface roughness since the reflected light reaches the sensor.

### Reliable detection of workpieces in various colors

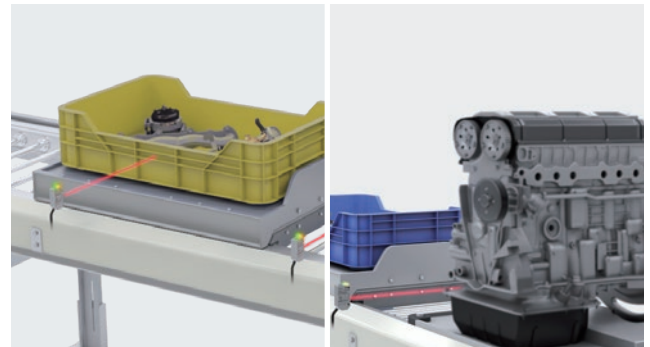
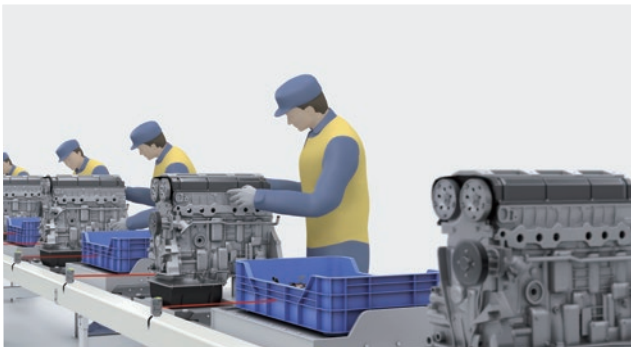

Detection is prone to be unstable because the sensing distance varies depending on the workpiece color. E3AS-F Sensors using the TOF technology is less likely to be affected by changes in color, providing stable detection for different colored containers or engine blocks without changing the set distance.

## TOF detects varying workpieces and measures distance

In the TOF (Time of Flight) method, the distance is measured based on the elapsed time instead of the amount of incident light received. Measurements therefore are not affected by changes in the color or material of the workpiece. This means that low-reflective workpieces, such as black rubber, can be detected from the same set distances.

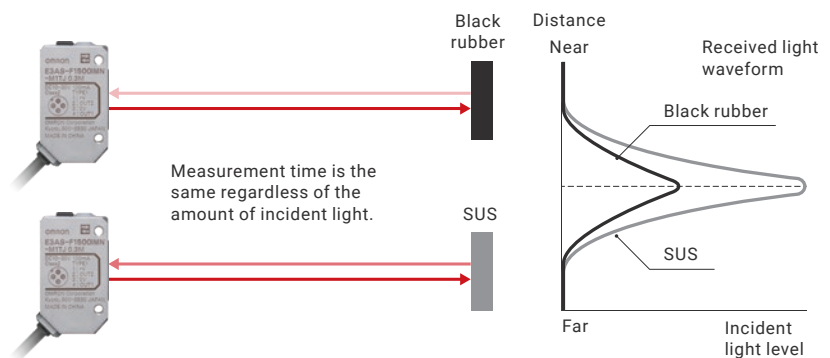

\*1. "PATENT PENDING" means that we applied for a patent in Japan. (As of December 2021)

# Flexible installation saves design time

Sensor space limitations make equipment design and retrofit work complicated, resulting in time-consuming work. The E3AS Series can be installed in challenging locations, which reduces design and commissioning time.

## E3AS-HL for inclined and close mounting

Install regardless of workpiece shape and angle

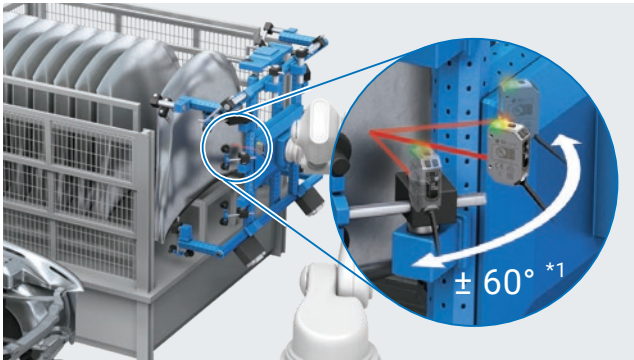

Curved surfaces of metal workpieces tend to affect detection, and it is time consuming to design the mounting angle. E3AS-HL Sensors can be mounted at a wide angle, making setup easy.

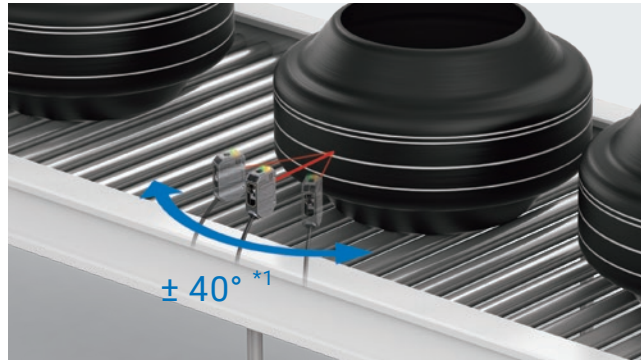

Curved surfaces of low-reflective workpieces tend to affect detection, and it is time consuming to design the mounting angle. E3AS-HL Sensors can be mounted at a wide angle, making setup easy.

## Install in confined spaces or near lights



Interference with other sensors must be considered during design. E3AS-HL Sensors prevent mutual interference between up to 4 sensors, allowing close installation for applications like item identification from hole positions.

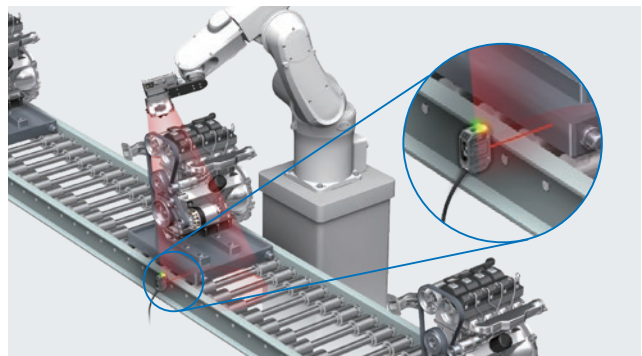

Effects of lights for cameras and sunlight must be considered during design. E3AS-HL Sensors can be operated under ambient illumination of 20,000 lx, which reaches the best in class level <sup>\*2</sup>. This allows you to install the sensors in the vicinity of lights.

## Sensing algorithm detects minimal reflected light from curved surface

**Industry First** <sup>\*2</sup> **PATENTED** <sup>\*3</sup>

The E3AS-HL Sensor is the industry-first laser Class 1 CMOS laser sensor that comes equipped with an FPGA. It performs high-speed sampling of received light waveforms at 10,000 times per second and OMRON's unique accumulation processing, significantly increasing its sensitivity. It amplifies the slightest amount of light to reliably detect workpieces with glossy surfaces, complex shaped workpieces, black rubber, or other workpieces from which it is difficult to receive reflected light.

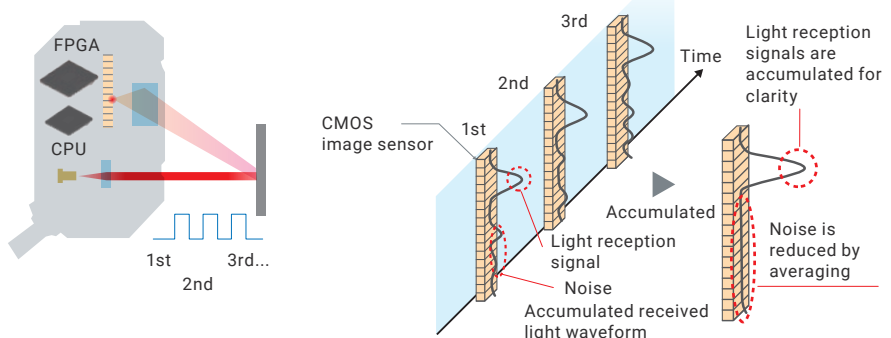

## E3AS-F for long-distance sensing

Install reflective sensors instead of through-beam sensors

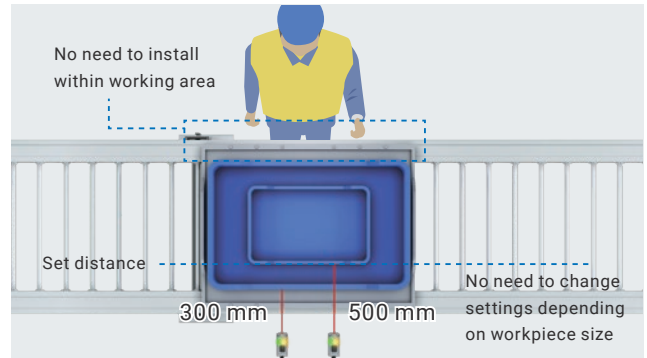
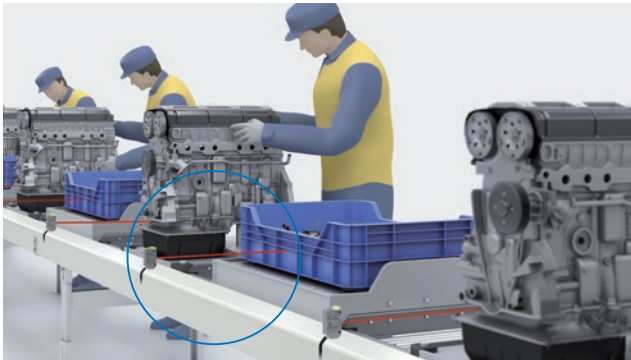

Reflective E3AS-F Sensors for long-distance sensing can be installed outside the working area, which is difficult with through-beam sensors. They use the TOF method to detect workpieces only and ignore workers.

## Installation almost unaffected by background

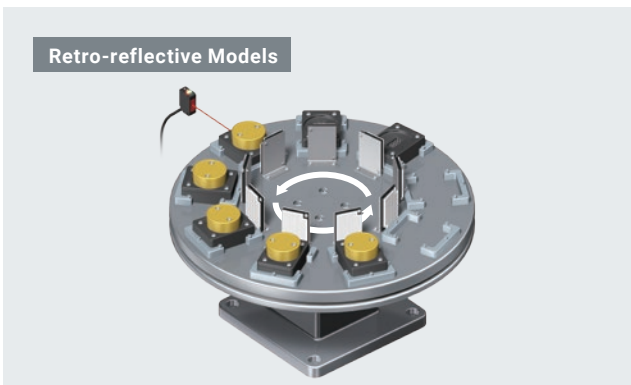

Reflectors are required behind workpieces to avoid effects of the background.

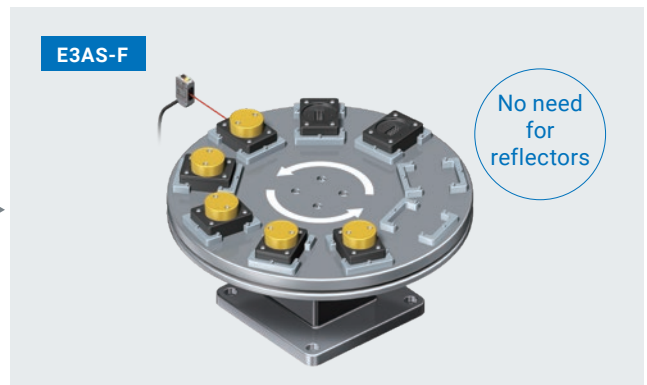

The TOF method that measures distance based on the elapsed time is hardly affected by the background, making design easy.

## More flexible mounting with flexible mounting bracket PATENT PENDING \*3

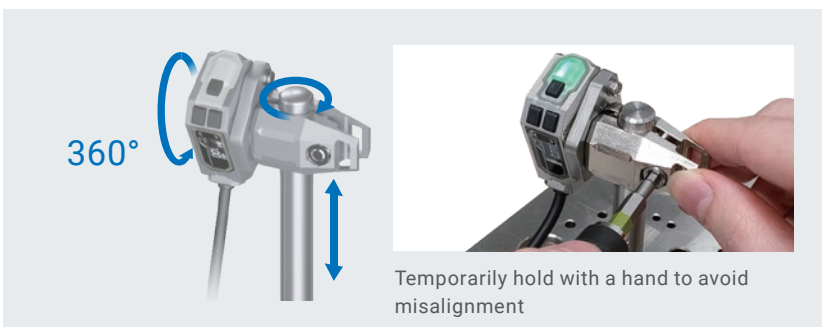

Optical axis can be easily adjusted in three directions: vertical, horizontal, and angular. This bracket can be mounted to any photoelectric sensor with a 25.4 mm mounting hole pitch as well as the E3AS Sensors.

\*1. The reference values were measured using the OMRON standard sensing object. \*2. Based on OMRON investigation in September 2019.

\*3. "PATENT PENDING" means that we applied for a patent in Japan, and "PATENTED" means that we obtained a patent in Japan. (As of December 2021)

## No special safety measures required for Class 1 laser



The E3AS Series is classified as Class 1, so laser safety measures are not required.

# Antifouling coating on sensing surface ensures stable operation even

When a sensor malfunction or breakage due to the environment causes a line stoppage during mass production, it can take a long time to restart. With the protected sensing surface, the E3AS Series helps minimize line downtime and maximize uptime.

## Antifouling coating on sensing surface reduces false detection and cleaning frequency

**Industry First** \*1 **PATENT PENDING** \*2

A dirty sensing surface can cause false detection due to the principle of photoelectric sensors. The E3AS Series has an industry-first antifouling coating on the sensing surface which prevents oil mist and dust from sticking to the sensing surface and keeps the lens from fogging as well. This reduces false detection and sensing surface cleaning frequency.

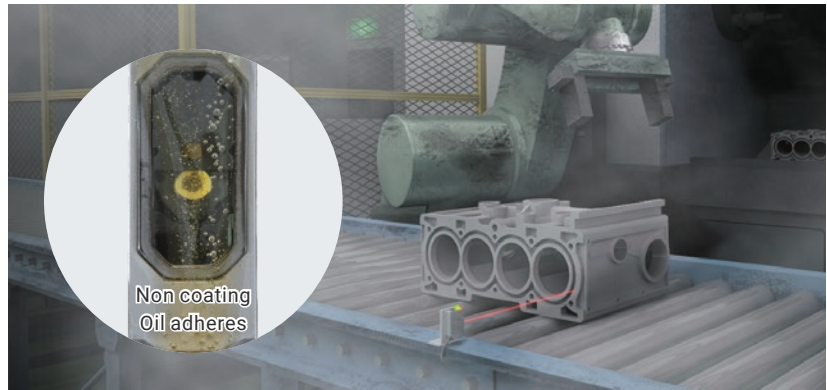
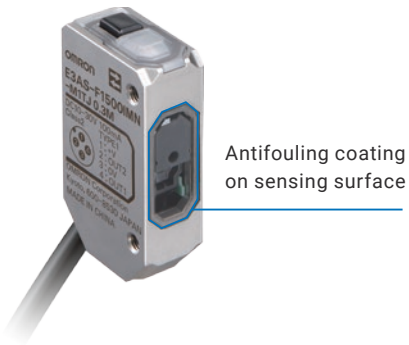

Water



Cutting oil



Dust



Water vapor

## Air blow unit enhances the effectiveness of antifouling coating

**PATENTED** \*2

Using an air blow unit greatly reduces the frequency of false detections since it prevents the sensing surface of sensors installed in confined, difficult to clean locations from becoming contaminated. It can be mounted to any photoelectric sensor with a 25.4 mm mounting hole pitch as well as the E3AS Sensors.



The air blow unit can be mounted on either side of any photoelectric sensor with a 25.4 mm mounting hole pitch



Air inlet

Air inlet position can be inverted



# in harsh environments

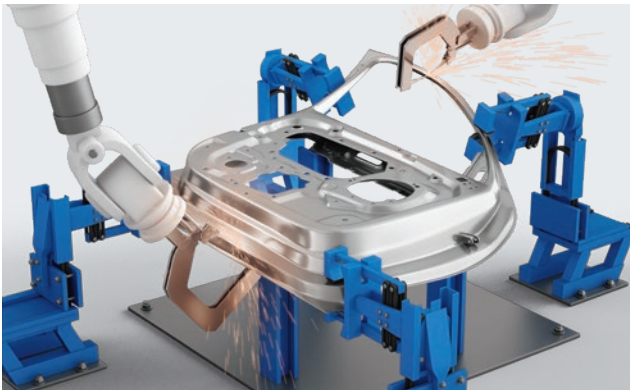

## Front protection cover reduces sensor failures

Welding spatter on the sensing surface or collision during operation can cause a sensor failure, and the sensor sometimes need to be replaced. Mounting the front protection cover prevents sensor failures. When any problems occur with the front protection cover, just replace it. There is no need to replace the sensor and rewire it.



## Unique case design reduces the frequency of replacements caused by failure

The sensor case is made of stainless steel (SUS316L). OMRON's unique laser welding technology for different materials enhances the sealing and adhesion between the stainless steel and resin. The laser welding technology for metals are used to weld the case and cover of the E3AS-F Sensor for secure sealing and adhesion between the stainless steel.

-  **IP69K**  
High temperatures/  
high water pressure
-  **IP67G**  
Oil resistance
-  **ECOLAB**  
Detergent  
resistance

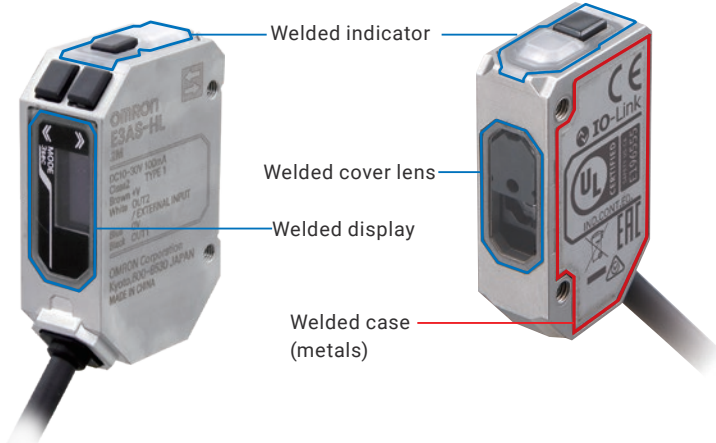

### Laser welding technology for different materials PATENTED \*2

It is a technology to weld different materials, resin and metal, using laser beams. Tiny holes are bored into the metal case, then the resin part is melted in by a laser for secure sealing and adhesion.

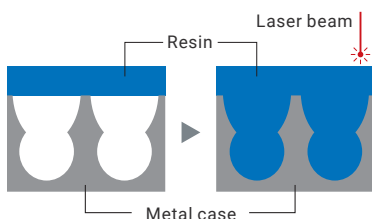

### Laser welding technology for different materials TOF E3AS-F

The metal case and cover are welded by a laser beam to seal the gaps. This ensures higher airtightness compared to adhesives, keeping out water and oil to reduce failures.

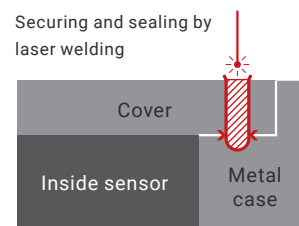

\*1. Based on OMRON investigation in September 2019.  
\*2. "PATENT PENDING" means that we applied for a patent in Japan, and "PATENTED" means that we obtained a patent in Japan. (As of December 2021)

# OLED display and teaching enable easy, quick, and optimal setting

E3AS Sensors allow virtually anyone to set optimal settings on the easy-to-read OLED display using the teaching method. Moreover, easy-to-standardize operability makes remote instructions simple.

## Easy-to-read, easy-to-understand OLED display

CMOS E3AS-HL

Displaying the threshold level and detected value on the same screen makes threshold level setting easy. In addition, wide viewing angle and display inverting allow on-site workers to easily see the display.

### Detected value and threshold level at a glance

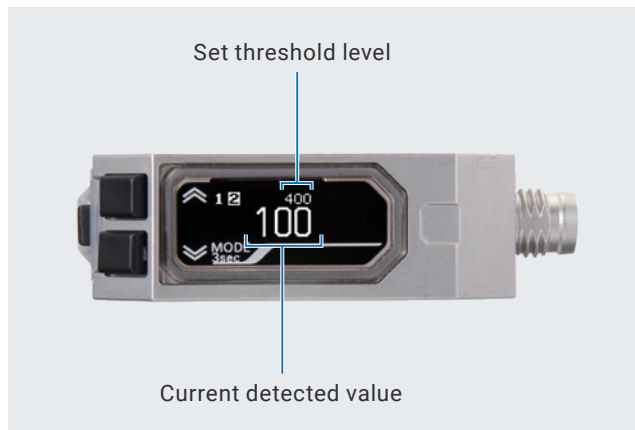

### Detection display switching based on purpose

Bar display to grasp detection margin at a glance



### ON/OFF display to easily check control output status



### Easy-to-read setup menu display



### Wide viewing angle allows reading from an angle



### Invert display depending on sensor installation orientation

Inverting: Disabled



Inverting: Enabled



## Single teach button prevents inconsistent settings

Easily and consistently set the optimal threshold level using the teach button.



### Background teaching

Set the threshold level at a point before the background (reference surface).

Hold teach button



### Two-point teaching

Set the threshold level at a value halfway between when a workpiece is present and when one is not.

Press the teach button each time with or without workpiece in place



### Key locking

The key locking function prevents operation mistakes after setting.

## Object teaching for easy setting to detect workpieces within specified range CMOS E3AS-HL

Object teaching allows you to easily set upper and lower threshold levels just by holding the button. This teaching is ideal for presence detection of workpieces without the background or within the specified distance range.

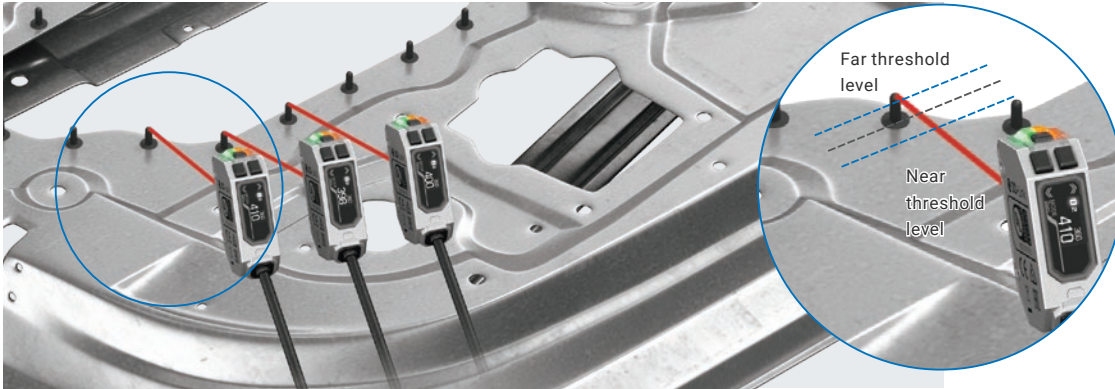

Just hold the button to set the threshold levels on the near and far sides of the workpiece position (reference position) at the same time. This teaching is used for presence detection of workpieces in the predetermined position.

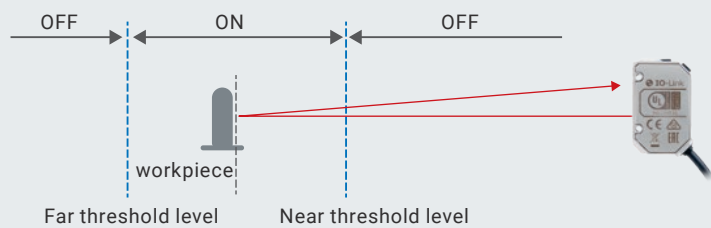

## Easy-to-standardize operations reduce commissioning time

When manufactures set up local production lines, the setup of sensors sometimes requires the experience and finesse of skilled workers and on-site instruction. The teaching method common to the E3AS Series enables you to standardize the operation procedures, facilitating remote instruction easier.

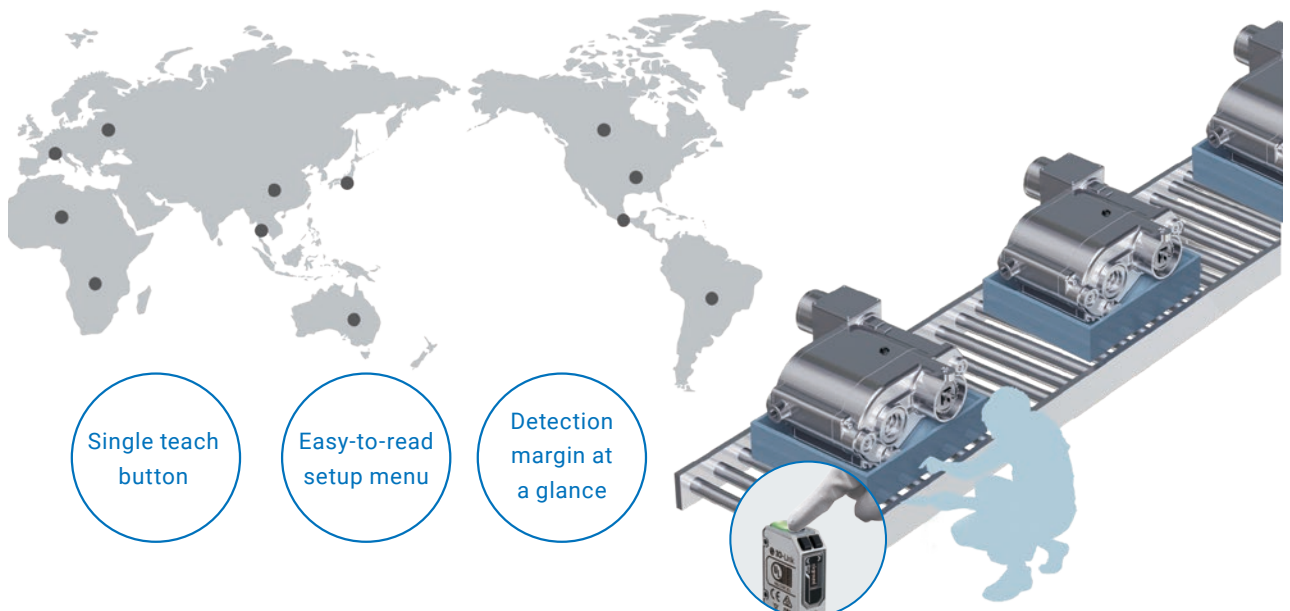

# Line commissioning and maintenance with less people in less time with IO-Link

With IO-Link, reduce commissioning time by batch-setting the sensors and cut troubleshooting time during mass production by utilizing field data.

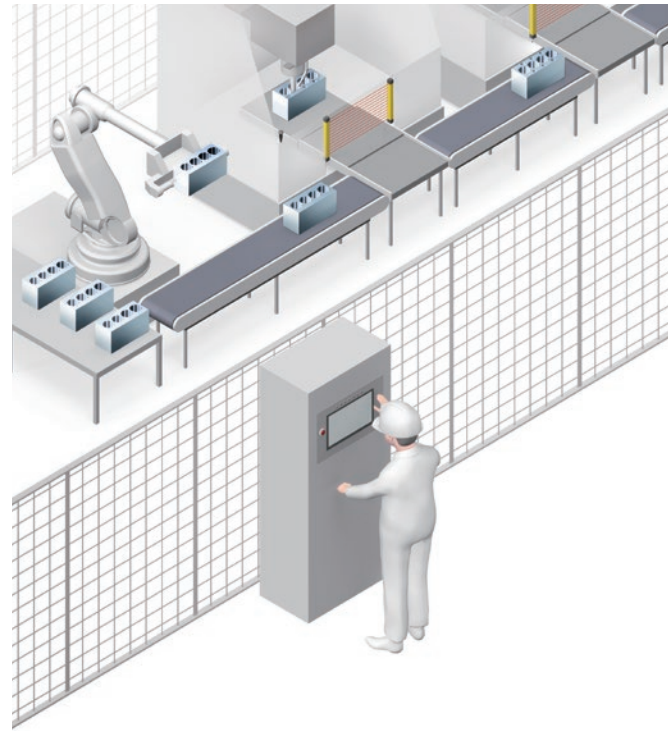
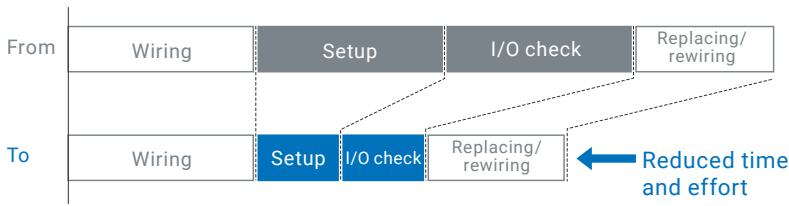

## Reduce commissioning time by batch-writing settings from IO-Link device configuration tool

Setting information can be batch-written to thousands of sensors on a line, effectively reducing commissioning time and inconsistent settings.

## Predictive monitoring and quick recovery by checking and monitoring sensor data

The monitor shows light intensity decrease due to sensing surface contamination or other reason, allowing users to take proactive actions to prevent potential false detections. This reduces the frequency of unexpected failures.

The diagram illustrates the IO-Link system architecture and its benefits. On the left, a Controller is connected to an IO-Link master via a Fieldbus network. The IO-Link master is connected to multiple IO-Link sensors. A bidirectional arrow indicates the flow of 'Setting information, etc.' from the master to the sensors and 'ON/OFF signal + sensor information' from the sensors to the master. The sensor information includes incident light level, sensing distance, and parameters.

A comparison box highlights the advantage of IO-Link sensors: 'Batch-writing of settings' (including threshold level and output mode) versus 'Manual entry of settings for each sensor' for standard sensors.

A graph titled 'Sensor data checking and monitoring' shows incident light level over time. The incident light level starts high and gradually decreases due to contamination. A notification is provided before the light level reaches an insufficient level, preventing an error.

**Batch-writing**

**Sensor data checking and monitoring**  
(Example) Incident light level output function \*1

## Model lineup

|  | E3AS-HL   |  | E3AS-F   |                                |
|--|---|--|--|--------------------------------|
| Appearance   |                            |  |  |                                |
| Case   | SUS316L   |  | SUS316L  | PBT/PC                         |
| Sensing distance   | 35 to 500 mm<br>35 to 150 mm  |  | 50 to 1500 mm<br>50 to 1000 mm   | 50 to 1500 mm<br>50 to 1000 mm |
| Standard detectable difference (mm)/ differential travel (%) | 35 to 50 mm: 1 mm<br>50 to 100 mm: 2 mm<br>100 to 150 mm: 4 mm<br>(E3AS-HL150: When response time is 10 ms) |  | 15% max.   | 15% max.                       |
| Setting method of threshold level                            | Teaching method/<br>Manual operation  |  | Teaching method  |                                |
| OLED display   | ✓   |  | —  | —                              |
| Antifouling coating  | ✓   |  | ✓  | ✓                              |
| Mutual interference prevention function                      | Up to 4 units   |  | —  | —                              |
| Degree of protection   | IP67/69K/67G/Ecolab   |  |  |                                |

Short-distance sensing models also available  
OMRON's unique light emitting element for stable detection of workpieces with low reflectivity



Distance-settable Photoelectric Sensors E3AS-L  
Sensing range: 10 to 80 mm/10 to 200 mm

## Accessories enhance sensor usability

The E3AS Series comes with a lineup of accessories that shorten sensor adjustment time upon commissioning and reduce the frequency of false detections during production. They can be used with non-E3AS sensors with a standard mounting hole pitch of 25.4 mm as well.

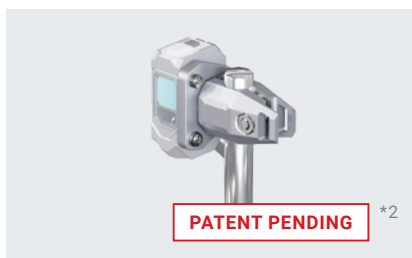

**PATENT PENDING** \*2

### Flexible Mounting Bracket

Optical axis can be adjusted in three directions: vertical, horizontal, and angular.

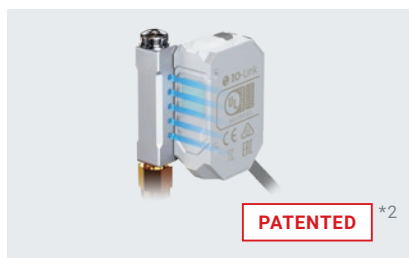

**PATENTED** \*2

### Air Blow Unit

Blows oil mist and dust off the sensing surface.



### Front Protection Cover \*3

Protects the sensing surface from welding spatter and collisions with robot arms.

\*1. E3AS-HL and E3AS-F only \*2. "PATENT PENDING" means that we applied for a patent in Japan, and "PATENTED" means that we obtained a patent in Japan. (As of December 2021) \*3. E3AS-HL only. Note: For details on ratings and specifications, refer to the *Ratings and Specifications* in this catalog.

# Applications and target workpieces



For workpieces with curved or irregular surfaces and low-reflective, glossy workpieces

CMOS Laser Sensor E3AS-HL

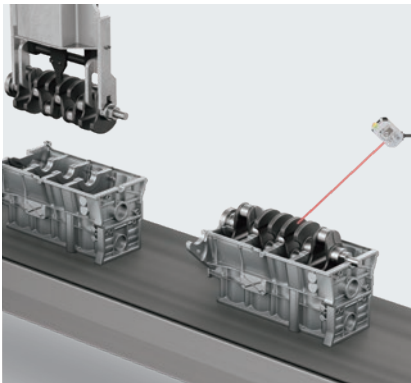

Presence detection of crankshafts



Presence detection of needle bearings

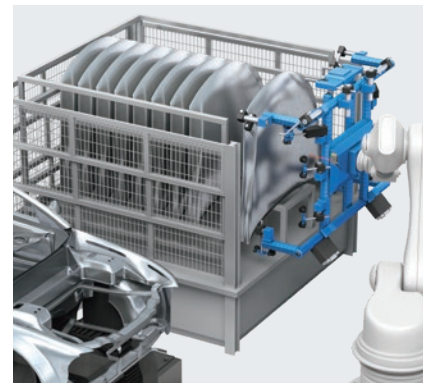

Presence detection of hoods



Parts identification using hole positions



Presence detection of bumpers

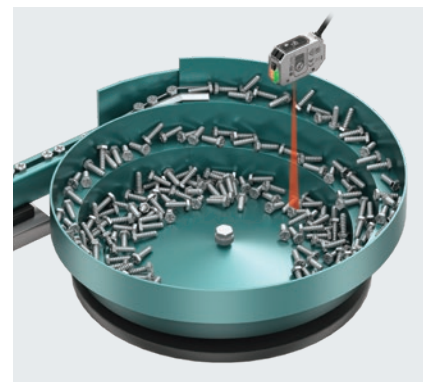

Detection of remaining quantities of workpieces in parts feeder

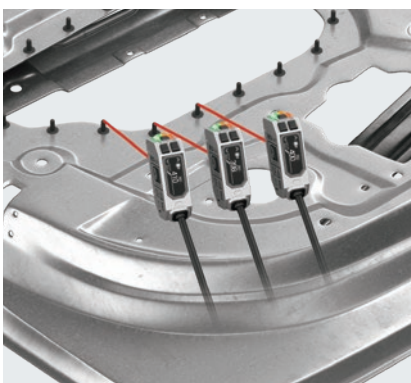

Presence detection of pins

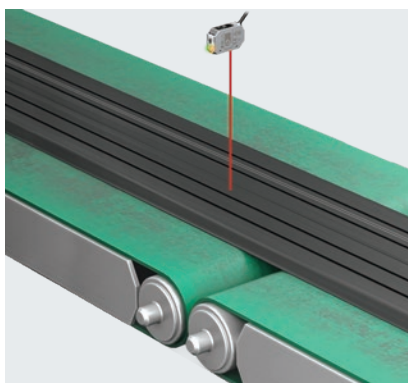

Presence detection of tires before building



Presence detection of green tires

Reliable detection of difficult workpieces  
The demonstration videos show the detection performance.

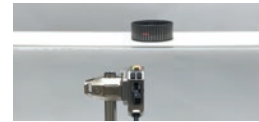

For large workpieces in various colors or with rough surfaces

TOF Laser Sensor E3AS-F

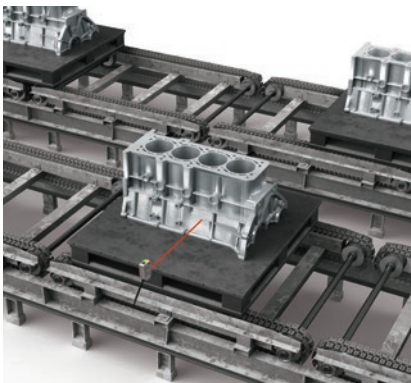

Presence detection of engine blocks



Presence detection of pallets

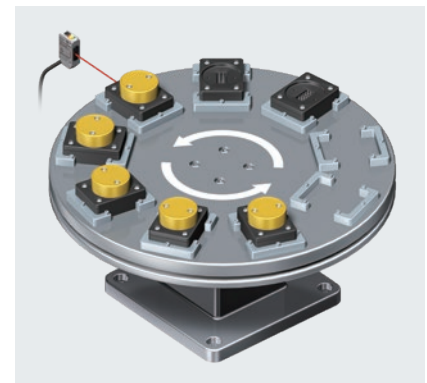

Presence detection of parts

## Reliable operation even in dusty or oil mist environments

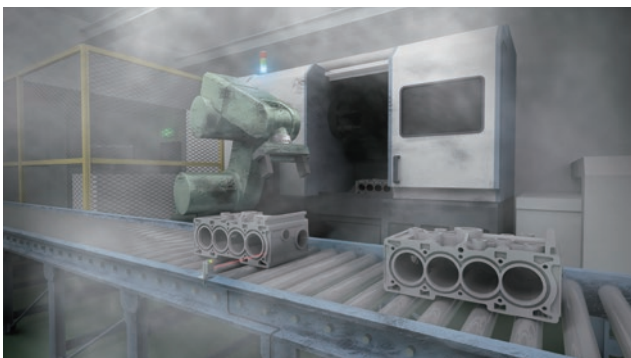

Dusty or oil mist environment

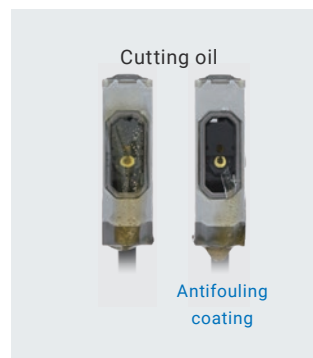

The videos show the antifouling feature of the antifouling coating and air blow unit.

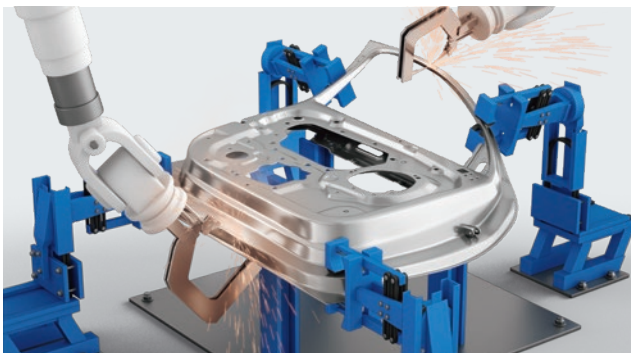

Welding spatter scatters environment







Distance-settable Photoelectric Sensors

# E3AS Series

## E3AS Series changes the “way of using” reflective photoelectric sensors

- Complete lineup of photoelectric sensors for various applications
- Teaching method allows anyone to set optimal threshold values
- Antifouling coating prevents contamination on the sensing surface
- Ecolab certified in addition to IP67/69K/67G protection
- All models with IO-Link connectivity (NPN type excluded)



For the most recent information on models that have been certified for safety standards, refer to your OMRON website.

 Refer to *Safety Precautions* on page 38.

## Table of Contents

|   |         |
|---|---------|
| Ordering Information .....                | page 18 |
| Ratings and Specifications .....          | page 24 |
| Engineering Data .....                    | page 26 |
| I/O Circuit Diagrams/ Timing Charts ..... | page 33 |
| Nomenclature .....                        | page 35 |
| Safety Precautions.....                   | page 38 |
| Dimensions.....                           | page 40 |

# E3AS Series

## Ordering Information

### E3AS-HL models [Refer to Dimensions on page 40]

#### Line beam type

Red light

| Connection method                            | Sensing distance<br>(white paper) | Output            |                         | Model                   |                      |
|--|-----------------------------------|-------------------|-------------------------|-------------------------|----------------------|
|  |                                   | IO-Link baud rate | NPN output              | PNP output              | COM3 (230.4 kbps) *3 |
| Pre-wired (2 m) *1                           |                                   | ---               | E3AS-HL500LMN 2M        | E3AS-HL500LMT 2M        |                      |
| M8 Connector                                 |                                   |                   | E3AS-HL500LMN M3        | E3AS-HL500LMT M3        |                      |
| M12 Pre-wired Smartclick Connector (0.3m) *2 |                                   |                   | E3AS-HL500LMN-M1TJ 0.3M | E3AS-HL500LMT-M1TJ 0.3M |                      |
| Pre-wired (2 m) *1                           |                                   | ---               | E3AS-HL150LMN 2M        | E3AS-HL150LMT 2M        |                      |
| M8 Connector                                 |                                   |                   | E3AS-HL150LMN M3        | E3AS-HL150LMT M3        |                      |
| M12 Pre-wired Smartclick Connector (0.3m) *2 |                                   |                   | E3AS-HL150LMN-M1TJ 0.3M | E3AS-HL150LMT-M1TJ 0.3M |                      |

#### Spot type

| Connection method                            | Sensing distance<br>(white paper) | Output            |                        | Model                  |                      |
|--|-----------------------------------|-------------------|------------------------|------------------------|----------------------|
|  |                                   | IO-Link baud rate | NPN output             | PNP output             | COM3 (230.4 kbps) *3 |
| Pre-wired (2 m) *1                           |                                   | ---               | E3AS-HL500MN 2M        | E3AS-HL500MT 2M        |                      |
| M8 Connector                                 |                                   |                   | E3AS-HL500MN M3        | E3AS-HL500MT M3        |                      |
| M12 Pre-wired Smartclick Connector (0.3m) *2 |                                   |                   | E3AS-HL500MN-M1TJ 0.3M | E3AS-HL500MT-M1TJ 0.3M |                      |
| Pre-wired (2 m) *1                           |                                   | ---               | E3AS-HL150MN 2M        | E3AS-HL150MT 2M        |                      |
| M8 Connector                                 |                                   |                   | E3AS-HL150MN M3        | E3AS-HL150MT M3        |                      |
| M12 Pre-wired Smartclick Connector (0.3m) *2 |                                   |                   | E3AS-HL150MN-M1TJ 0.3M | E3AS-HL150MT-M1TJ 0.3M |                      |

\*1. Models with 5-m cable length are also available with "5M" suffix. (Example: E3AS-HL500LMN 5M/E3AS-HL500MN 5M)



\*2. M8 Pre-wired Connector Models are also available. When ordering, add "-M3J 0.3M" to the end of the model number (e.g., E3AS-HL500LMN-M3J 0.3M/E3AS-HL500MN-M3J 0.3M).

\*3. COM2 (38.4kbps) Models are also available. When ordering, add "D" to the end of the model number (e.g., E3AS-HL500LMD 2M/E3AS-HL500MD 2M).



## E3AS-F models [Refer to Dimensions on page 41]

### Metal case type

 Infrared light

| Connection method                            | Sensing distance (white paper)  | Model             |                         |                         |
|--|---|-------------------|-------------------------|-------------------------|
|  |   | Output            | NPN output              | PNP output              |
|  |   | IO-Link baud rate | ---                     | COM3 (230.4 kbps) *3    |
| Pre-wired (2 m) *1                           |  |                   | E3AS-F1500IMN 2M        | E3AS-F1500IMT 2M        |
| M8 Connector                                 |   |                   | E3AS-F1500IMN M3        | E3AS-F1500IMT M3        |
| M12 Pre-wired Smartclick Connector (0.3m) *2 |   |                   | E3AS-F1500IMN-M1TJ 0.3M | E3AS-F1500IMT-M1TJ 0.3M |
| Pre-wired (2 m) *1                           |  |                   | E3AS-F1000IMN 2M        | E3AS-F1000IMT 2M        |
| M8 Connector                                 |   |                   | E3AS-F1000IMN M3        | E3AS-F1000IMT M3        |
| M12 Pre-wired Smartclick Connector (0.3m) *2 |   |                   | E3AS-F1000IMN-M1TJ 0.3M | E3AS-F1000IMT-M1TJ 0.3M |

### Plastic case type

| Connection method                            | Sensing distance (white paper)  | Model             |                         |                         |
|--|---|-------------------|-------------------------|-------------------------|
|  |   | Output            | NPN output              | PNP output              |
|  |   | IO-Link baud rate | ---                     | COM3 (230.4 kbps) *3    |
| Pre-wired (2 m) *1                           |   |                   | E3AS-F1500IPN 2M        | E3AS-F1500IPT 2M        |
| M8 Connector                                 |   |                   | E3AS-F1500IPN M3        | E3AS-F1500IPT M3        |
| M12 Pre-wired Smartclick Connector (0.3m) *2 |   |                   | E3AS-F1500IPN-M1TJ 0.3M | E3AS-F1500IPT-M1TJ 0.3M |
| Pre-wired (2 m) *1                           |  |                   | E3AS-F1000IPN 2M        | E3AS-F1000IPT 2M        |
| M8 Connector                                 |   |                   | E3AS-F1000IPN M3        | E3AS-F1000IPT M3        |
| M12 Pre-wired Smartclick Connector (0.3m) *2 |   |                   | E3AS-F1000IPN-M1TJ 0.3M | E3AS-F1000IPT-M1TJ 0.3M |

## E3AS-L models [Refer to Dimensions on page 42]

 Red light

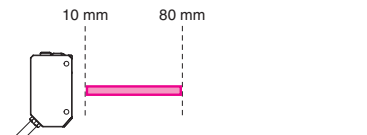
| Connection method                            | Sensing distance (white paper)  | Model             |                       |                       |
|--|---|-------------------|-----------------------|-----------------------|
|  |   | Output            | NPN output            | PNP output            |
|  |   | IO-Link baud rate | ---                   | COM3 (230.4 kbps) *3  |
| Pre-wired (2 m) *1                           |  |                   | E3AS-L200MN 2M        | E3AS-L200MT 2M        |
| M8 Connector                                 |   |                   | E3AS-L200MN M3        | E3AS-L200MT M3        |
| M12 Pre-wired Smartclick Connector (0.3m) *2 |   |                   | E3AS-L200MN-M1TJ 0.3M | E3AS-L200MT-M1TJ 0.3M |
| Pre-wired (2 m) *1                           |  |                   | E3AS-L80MN 2M         | E3AS-L80MT 2M         |
| M8 Connector                                 |   |                   | E3AS-L80MN M3         | E3AS-L80MT M3         |
| M12 Pre-wired Smartclick Connector (0.3m) *2 |   |                   | E3AS-L80MN-M1TJ 0.3M  | E3AS-L80MT-M1TJ 0.3M  |

\*1. Models with 5-m cable length are also available with "5M" suffix. (Example: E3AS-F1500IMN 5M/E3AS-F1500IPN 5M/E3AS-L200MN 5M)

\*2. M8 Pre-wired Connector Models are also available. When ordering, add "-M3J 0.3M" to the end of the model number (e.g., E3AS-F1500IMN-M3J 0.3M/E3AS-F1500IPN-M3J 0.3M/E3AS-L200MN-M3J 0.3M).

\*3. COM2 (38.4kbps) Models are also available. When ordering, add "D" to the end of the model number (e.g., E3AS-F1500IMD 2M/E3AS-F1500IPD 2M/E3AS-L200MD 2M).

# E3AS Series



## Accessories (Sold Separately)

### Sensor I/O Connectors (Sockets on One Cable End)

(Models for Connectors / Pre-wired Connectors)



A Sensor I/O Connector is not provided with the Sensor. It must be ordered separately as required.

#### Round Water-resistant Connectors XS3F-M8 series

| Appearance  | Cable specification | Cable diameter (mm) | Cable connection direction | Cable length (m) | Sensor I/O Connector model number |
|---|---------------------|---------------------|----------------------------|------------------|-----------------------------------|
| M8 Connector<br>Straight type<br><br>Right-angle type<br> | PVC robot cable     | 4 dia.              | Straight                   | 2                | XS3F-M421-402-R                   |
|   |                     |                     |                            | 5                | XS3F-M421-405-R                   |
|   |                     |                     | Right-angle                | 2                | XS3F-M422-402-R                   |
|   |                     |                     |                            | 5                | XS3F-M422-405-R                   |

**Note:** 1. The XS3W (Socket and Plug on Cable Ends), Cable length 1m and 10m is also available. Refer to *XS3 Series Datasheet* (Cat. No. G147).  
 2. The connectors will not rotate after they are connected.  
 3. The cable is fixed at an angle of 180° from the sensor emitter/receiver surface.

#### Round Water-resistant Connectors XS5 series









| Appearance  | Cable specification | Cable diameter (mm) | Cable connection direction | Cable length (m) | Sensor I/O Connector model number |
|---|---------------------|---------------------|----------------------------|------------------|-----------------------------------|
| M12 Smartclick Connector<br>Straight type<br><br>Right-angle type<br> | PVC robot cable     | 6 dia.              | Straight                   | 2                | XS5F-D421-D80-F                   |
|   |                     |                     |                            | 5                | XS5F-D421-G80-F                   |
|   |                     |                     | Right-angle                | 2                | XS5F-D422-D80-F                   |
|   |                     |                     |                            | 5                | XS5F-D422-G80-F                   |

**Note:** 1. The XS5W (Socket and Plug on Cable Ends) is also available. Refer to *XS5* on your OMRON website for details.  
 2. The connectors will not rotate after they are connected.  
 3. The cable is fixed at an angle of 180° from the sensor emitter/receiver surface.

**Mounting Brackets**

A Mounting Bracket is not enclosed with the Sensor. Order a Mounting Bracket separately if required.

For E3AS-HL series [Refer to *Dimensions* on page 43]

| Appearance  | Model (material)  | Pre-wired | M12 Pre-wired Smartclick Connector | M8 Connector |
|---|-------------------|-----------|------------------------------------|--------------|
| <b>L-shaped Mounting Bracket</b><br>             | E39-L221 (SUS304) | Yes       | Yes                                | ---          |
| <b>Horizontal Protective Cover Bracket</b><br>   | E39-L222 (SUS304) | Yes       | Yes                                | ---          |
| <b>Rear Mounting Bracket</b><br>                 | E39-L223 (SUS304) | Yes       | Yes                                | Yes *2       |
| <b>Robust Mounting Bracket</b><br>              | E39-L224 (SUS304) | Yes       | Yes                                | ---          |
| <b>L-shaped Mounting Bracket</b><br>           | E39-L231 (SUS304) | --- *1    | --- *1                             | Yes *3       |
| <b>Horizontal Protective Cover Bracket</b><br> | E39-L232 (SUS304) | --- *1    | --- *1                             | Yes *3       |
| <b>Robust Mounting Bracket</b><br>             | E39-L234 (SUS304) | --- *1    | --- *1                             | Yes *3       |
| <b>Front Protection Cover</b><br>              | E39-E19 *4        | Yes       | Yes                                | Yes          |

\*1. Can be used for Pre-wired models and M12 Pre-wired Smartclick Connector models. However, confirm the bracket shape in advance.

\*2. Confirm the installation environment and bracket shape of the Sensor I/O Connector to be connected.

\*3. Use an L-shaped Sensor I/O Connector. Straight types cannot be installed.

\*4. Front Protection Cover is Accessory for E3AS-HL. E3AS-F model and E3AS-L model cannot be installed.

Ordering Information

Rating and Specifications

Engineering Data

I/O Circuit Diagrams/Timing Charts







Nomenclature

Safety Precautions

Dimensions

# E3AS Series

For E3AS-F/L models [Refer to *Dimensions* on page 47]

| Appearance  | Model (material)  | Pre-wired | M12 Pre-wired Smartclick Connector | M8 Connector |
|---|-------------------|-----------|------------------------------------|--------------|
| <b>L-shaped Mounting Bracket</b><br>             | E39-L201 (SUS304) | Yes       | Yes                                | ---          |
| <b>Horizontal Protective Cover Bracket</b><br>   | E39-L202 (SUS304) | Yes       | Yes                                | ---          |
| <b>Rear Mounting Bracket</b><br>                 | E39-L203 (SUS304) | Yes       | Yes                                | Yes *2       |
| <b>Robust Mounting Bracket</b><br>              | E39-L204 (SUS304) | Yes       | Yes                                | ---          |
| <b>L-shaped Mounting Bracket</b><br>           | E39-L211 (SUS304) | --- *1    | --- *1                             | Yes *3       |
| <b>Horizontal Protective Cover Bracket</b><br> | E39-L212 (SUS304) | --- *1    | --- *1                             | Yes *3       |
| <b>Robust Mounting Bracket</b><br>             | E39-L214 (SUS304) | --- *1    | --- *1                             | Yes *3       |





\*1. Can be used for Pre-wired models and M12 Pre-wired Smartclick Connector models. However, confirm the bracket shape in advance.

\*2. Confirm the installation environment and bracket shape of the Sensor I/O Connector to be connected.

\*3. Use an L-shaped Sensor I/O Connector. Straight types cannot be installed.

Common to E3AS series [Refer to *Dimensions* on page 50]

A Mounting Bracket is not enclosed with the Sensor. Order a Mounting Bracket separately if required.

| Appearance  | Model (material)            | Pre-wired | M12 Pre-wired Smartclick Connector | M8 Connector |
|---|-----------------------------|-----------|------------------------------------|--------------|
| <b>Flexible Mounting Bracket</b><br> | <b>E39-L261 *1 (SUS304)</b> | Yes       | Yes                                | Yes          |
| <b>Post 50 mm</b><br>                | <b>E39-L262</b>             | Yes       | Yes                                | Yes          |
| <b>Post 100 mm</b><br>              | <b>E39-L263</b>             | Yes       | Yes                                | Yes          |
| <b>Air Blow Unit</b><br>           | <b>E39-E16 *2</b>           | Yes       | Yes                                | Yes          |

\*1. The Flexible Mounting Bracket is not provided with a Post (E39-L262/E39-L263). It must be ordered separately.

\*2. The tube for air is not included.

# E3AS Series

## Ratings and Specifications

### E3AS-HL models

| Item                              | Model          | Sensing method   |  | Triangulation                           |               |   |               |
|-----------------------------------|----------------|--|--|---|---------------|---|---------------|
|                                   |                | Type   |  | Metal case (□: M), Plastic case (□: P)  |               |   |               |
|                                   |                | NPN Output   | PNP Output/COM3  | E3AS-HL500MN                            | E3AS-HL500LMN | E3AS-HL150MN  | E3AS-HL150LMN |
|                                   |                |  |  | E3AS-HL500MT                            | E3AS-HL500LMT | E3AS-HL150MT  | E3AS-HL150LMT |
| Sensing distance *1               |                | 35 mm to the set distance  |  |   |               | 35 mm to the set distance   |               |
| Setting range *1                  |                | 35 to 500 mm   |  |   |               | 35 to 150 mm  |               |
| Standard detectable difference *1 |                | 35 to 180 mm: 9 mm<br>180 to 300 mm: 18 mm<br>300 to 400 mm: 30 mm<br>400 to 500 mm: 45 mm<br>at 10 m sec  |  |   |               | 35 to 50 mm: 1 mm<br>50 to 100 mm: 2 mm<br>100 to 150 mm: 4 mm<br>at 10 m sec               |               |
| Display minimum unit value        |                | 1 mm   |  |   |               | 0.1 mm  |               |
| Spot size (reference value) *2    |                | 2.5 mm × 1.5 mm<br>at distance of 500 mm   |  | 18 mm × 1.5 mm<br>at distance of 500 mm |               | 2.5 mm × 1.3 mm<br>at distance of 150 mm  |               |
| Light source (wavelength)         |                | Red laser (660 nm), Class1 (IEC/EN60825-1:2014)  |  |   |               |   |               |
| Power supply voltage              |                | 10 to 30 VDC (including 10% ripple (p-p)), Class2  |  |   |               |   |               |
| Current consumption               |                | 100 mA max.  |  |   |               |   |               |
| Input/<br>output                  | Control output |  | Load power supply voltage 30 VDC max. (Class2), the total load current of the two outputs is 100 mA max. Residual voltage (Load current 10 mA max.: 1 VDC max., Load current 10 to 100 mA: 2 VDC max.) Open-collector output (NPN/PNP output depending on model) N.O. (Normally Open) / N.C. (Normally Close) selectable |   |               |   |               |
|                                   | NPN            |  | OUTPUT 1: NO (Normally open), OUTPUT 2: NC (Normally closed)   |   |               |   |               |
|                                   | PNP/COM3       |  | OUTPUT 1: NO (Normally open)/COM□, OUTPUT 2: NC (Normally closed)  |   |               |   |               |
| External input                    |                | Laser OFF / Teaching / Zero reset selectable<br>NPN ON time: 0 V short-circuit or 1.5 V or less, OFF time: Power supply voltage short-circuit or open<br>PNP ON time: Power supply voltage short-circuit or within power supply voltage - 1.5 V, OFF time: 0 V short-circuit or open |  |   |               |   |               |
| Response time                     |                | 1.5 ms / 10 ms / 50 ms selectable  |  |   |               |   |               |
| Threshold setting method          |                | Teaching method / Manual Operations / IO-Link communications   |  |   |               |   |               |
| Mutual interference prevention    |                | 4 units max. (when using the mutual interference prevention function)  |  |   |               |   |               |
| Ambient illumination              |                | Receiver surface illuminance:<br>Incandescent lamp: 20,000 lx max., Sunlight: 25,000 lx max.<br>at distance of 250 mm<br>Incandescent lamp: 5,000 lx max., Sunlight: 10,000 lx max.<br>at distance of 500 mm   |  |   |               | Receiver surface illuminance:<br>Incandescent lamp: 8,000 lx max., Sunlight: 16,000 lx max. |               |

\*1. Measured with OMRON's standard workpiece (White ceramic).

\*2. Defined by D4σ method at the maximum sensing distance. Detection may be influenced if there is light leakage outside the defined region and the surroundings of the target object have a high reflectance in comparison to the target object. Also, when detecting a workpiece that is smaller than the spot size, a correct value may not be obtained.

### E3AS-F models

| Item  | Model          | Sensing method   |  | TOF (Time of flight)                   |               |  |  |
|---|----------------|--|--|--|---------------|--|--|
|   |                | Type   |  | Metal case (□: M), Plastic case (□: P) |               |  |  |
|   |                | NPN output   | PNP output/ COM3   | E3AS-F1500I□N                          | E3AS-F1000I□N |  |  |
|   |                |  |  | E3AS-F1500I□T                          | E3AS-F1000I□T |  |  |
| Sensing distance                                |                | 50 mm to the set distance<br>(White paper or black paper 200 × 200 mm)                   |  |  |               | 50 mm to the set distance<br>(White paper or black paper 200 × 200 mm)                 |  |
| Setting range                                   |                | 100 to 1,500 mm (White paper 200 × 200 mm)<br>100 to 1,000 mm (Black paper 200 × 200 mm) |  |  |               | 100 to 1,000 mm (White paper 200 × 200 mm)<br>100 to 500 mm (Black paper 200 × 200 mm) |  |
| Spot diameter (reference value)                 |                | 95 mm dia. (at distance of 1,000 mm)   |  |  |               |  |  |
| Differential travel                             |                | 15% max. of set distance (Set distance 200 mm min.)                                      |  |  |               |  |  |
| Reflectivity characteristic (black/white error) |                | 10% max. of set distance (Set distance 200 mm min.)                                      |  |  |               |  |  |
| Light source (wavelength)                       |                | Infrared laser (940 nm) Class1 (IEC/EN60825-1:2014)                                      |  |  |               |  |  |
| Power supply voltage                            |                | 10 to 30 VDC (including 10% ripple (p-p)), Class2  |  |  |               |  |  |
| Current consumption                             |                | 30 mA max.   |  |  |               |  |  |
| Input/<br>output                                | Control output |  | Load power supply voltage: 30 VDC max., Class2, Load current: 100 mA max. (Residual voltage: Load current of less than 10 mA: 1 V max. Load current of 10 to 100 mA: 2 V max.) Open-collector output (NPN/PNP output depending on model) |  |               |  |  |
|   | NPN            |  | OUTPUT 1: NO (Normally open), OUTPUT 2: NC (Normally closed)   |  |               |  |  |
|   | PNP/COM3       |  | OUTPUT 1: NO (Normally open)/COM□, OUTPUT 2: NC (Normally closed)  |  |               |  |  |
| Response time                                   |                | Operate or reset: 150 ms max.  |  |  |               | Operate or reset: 90 ms max.   |  |
| Threshold setting method                        |                | Teaching method/IO-Link communications   |  |  |               |  |  |
| Ambient illumination                            |                | Incandescent lamp: 3,000 lx max., Sunlight: 10,000 lx max.                               |  |  |               |  |  |



## E3AS-L models

| Item  | Sensing method |   | Triangulation  |  |
|---|----------------|---|--|--|
|   | Model          | NPN Output  | E3AS-L200MN  | E3AS-L80MN   |
|   |                | PNP Output/COM3   | E3AS-L200MT  | E3AS-L80MT   |
| Sensing distance                                |                | 10 mm to the set distance (White paper or black paper 100 × 100 mm) |  |  |
| Setting range                                   |                | 40 to 200 mm (White paper or black paper 100 × 100 mm)              |  | 20 to 80 mm (White paper or black paper 100 × 100 mm)                        |
| Spot diameter (reference value)                 |                | 25 × 25 mm at distance of 200 mm                                    |  | 4 mm dia. (at distance of 80 mm)   |
| Differential travel                             |                | 10% max. of set distance  |  | White paper: 2% max. of set distance<br>Black paper: 5% max. of set distance |
| Reflectivity characteristic (black/white error) |                | 10% max. of set distance  |  | 5% max. of set distance  |
| Light source (wavelength)                       |                | Red LED (624 nm)  |  | Red LED (650 nm)   |
| Power supply voltage                            |                | 10 to 30 VDC (including 10% ripple (p-p)), Class2                   |  |  |
| Current consumption                             |                | 35 mA max.  |  |  |
| Input/output                                    | Control output |   | Load power supply voltage: 30 VDC max., Class2, Load current: 100 mA max.<br>(Residual voltage: Load current of less than 10 mA: 1 V max. Load current of 10 to 100 mA: 2 V max.)<br>Open-collector output (NPN/PNP output depending on model) |  |
|   | NPN            |   | OUTPUT 1: NO (Normally open), OUTPUT 2: NC (Normally closed)   |  |
|   | PNP/COM3       |   | OUTPUT 1: NO (Normally open)/COM□, OUTPUT 2: NC (Normally closed)  |  |
| Response time                                   |                | Operate or reset: 1 ms max.   |  |  |
| Threshold setting method                        |                | Teaching method/IO-Link communications                              |  |  |
| Ambient illumination                            |                | Incandescent lamp: 3,000 lx max., Sunlight: 10,000 lx max.          |  |  |

## Common to E3AS series

| Series                               | E3AS-HL  | E3AS-F   | E3AS-L   |
|--------------------------------------|--|--|--|
| Protection circuits                  | Power supply reverse polarity protection, Output short-circuit protection, and Output reverse polarity protection  |  |  |
| Ambient temperature range            | Operating: -10 to 50°C,<br>Storage: -25 to 70°C<br>(with no icing or condensation)   | Operating: -20 to 55°C,<br>Storage: -40 to 70°C<br>(with no icing or condensation)                                   | Operating: -25 to 55°C,<br>Storage: -40 to 70°C<br>(with no icing or condensation) |
| Ambient humidity range               | Operating: 35% to 85%, Storage: 35% to 95% (with no condensation)  |  |  |
| Insulation resistance                | 20 MΩ min. at 500 VDC  |  |  |
| Dielectric strength                  | 1,000 VAC, 50/60 Hz for 1 min  |  |  |
| Vibration resistance                 | 10 to 55 Hz with a 1.5-mm double amplitude for 2 hours each in X, Y, and Z directions  |  |  |
| Shock resistance                     | 500 m/s <sup>2</sup> for 3 times each in X, Y, and Z directions  |  |  |
| Degree of protection                 | IP67 (IEC60529) and IP67G *1 (JIS C 0920 Annex 1), IP69K (ISO20653)  |  |  |
| Indicators                           | OLED Display (White), Power/Communication indicator (Green*), Operation indicator (Orange)<br>* IO-Link Communication mode: blinking   | Operation indicator (orange), Stability & Communication indicator (green*)<br>* IO-Link Communication mode: blinking |  |
| Connection method                    | Pre-wired (standard cable length: 2 m), M8 Connector, M12 Pre-wired Smartclick Connector (standard cable length: 0.3m)   |  |  |
| Weight (packed state/Sensor only)    | Pre-wired (2 m)  | Approx. 180 g/approx. 110 g  | Approx. 135 g/approx. 90 g   |
|                                      | M8 Connector   | Approx. 120 g/approx. 50 g   | Approx. 75 g/approx. 30 g  |
|                                      | M12 Pre-wired Smartclick Connector (0.3m)  | Approx. 150 g/approx. 80 g   | Approx. 95 g/approx. 50 g  |
| Materials                            | Case   | Stainless steel (SUS316L)  | Stainless steel (SUS316L)  |
|                                      | Lens cover and Display   | Methacrylic resin (PMMA) (Lens cover: Antifouling coating)   |  |
|                                      | Indicator  | Polyamide 11 (PA11)  | Metal case type: Polyamide 11 (PA11)<br>Plastic case type: Polyethersulfone (PES)  |
| Main IO-Link functions               | Operation mode switching between NO and NC, execution of teaching (2-point teaching, Background teaching), setup of the threshold, timer function of the control output and timer time selecting, Restore Factory Settings, Key Lock (Unlock, Lock, Lock (No Button)), monitor output* (Detection level, Incident light level) * Only for E3AS-HL and E3AS-F |  |  |
| IO-Link Communication specifications | IO-Link specification  | Ver. 1.1   |  |
|                                      | Baud rate  | COM3 (230.4 kbps)  |  |
|                                      | Data length  | PD size: 4 bytes, OD size: 1 byte (M-sequence type: TYPE_2_V)  | PD size: 1 byte, OD size: 1 byte (M-sequence type: TYPE_2_1)                       |
|                                      | Minimum cycle time   | COM3: 1.2 ms   |  |
| Accessories                          | Instruction manual, compliance sheet, index list (attached for IO-Link type only)<br>E3AS-HL: FDA certification label and Warning label<br>E3AS-F: FDA certification label<br>Note: Mounting Brackets must be ordered separately.  |  |  |

\*1. The IP67G is the degree of protection which is defined according to the JIS (Japanese Industrial Standards).

The IP67 indicates the same level of protection as defined by the IEC, and the G indicates that a device has resistance to oil.

# E3AS Series

## Engineering Data (Reference Value)

### E3AS-HL models

#### Spot Diameter vs. Sensing Distance

##### Spot type

E3AS-HL500□

E3AS-HL150□

##### Line beam type

E3AS-HL500L□

E3AS-HL150L□

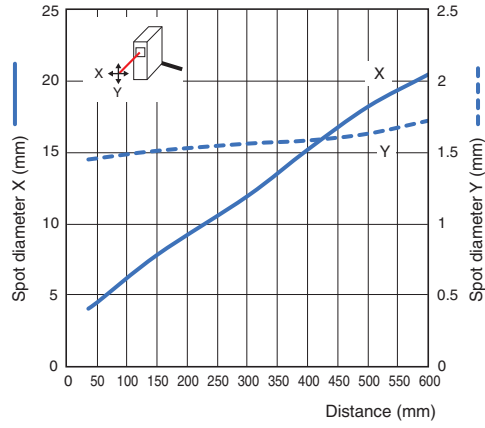
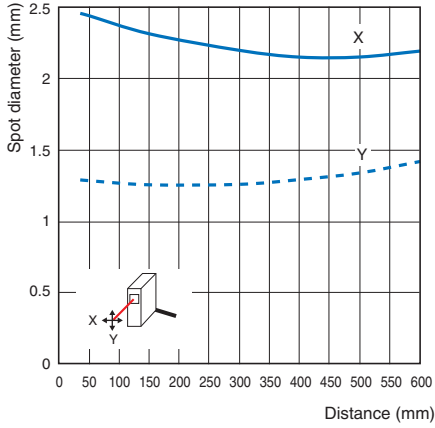

#### Sensing Object Angle Characteristics

##### Spot type/Line beam type

E3AS-HL500□

##### Horizontal

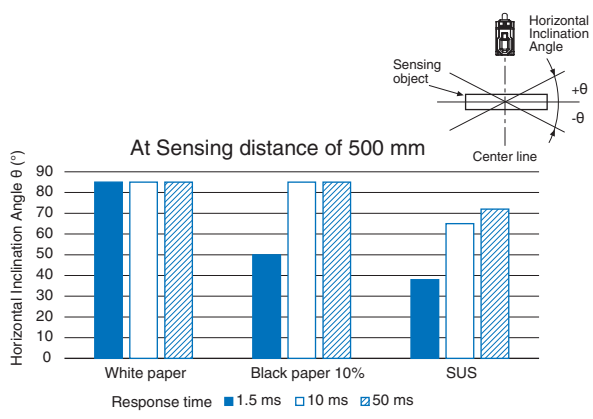
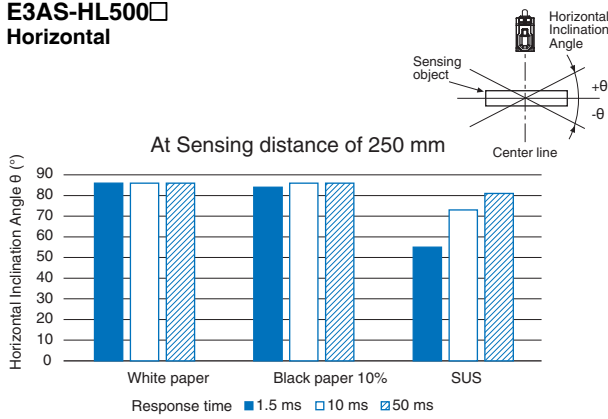

E3AS-HL150□

##### Horizontal

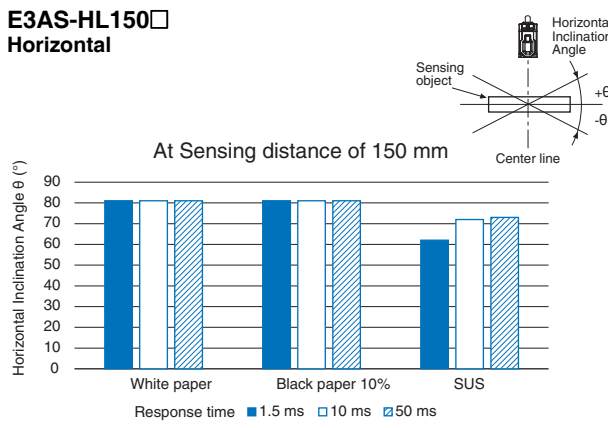

Minimum Measurement Gap Vs. Distance

Spot type/Line beam type

E3AS-HL500□

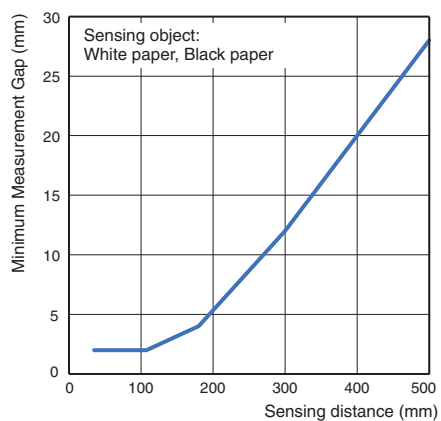

E3AS-HL150□

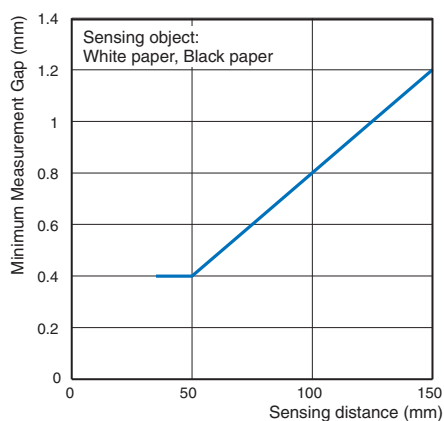

## E3AS-F models

### Operating Range

#### E3AS-F1500□

##### Z directions

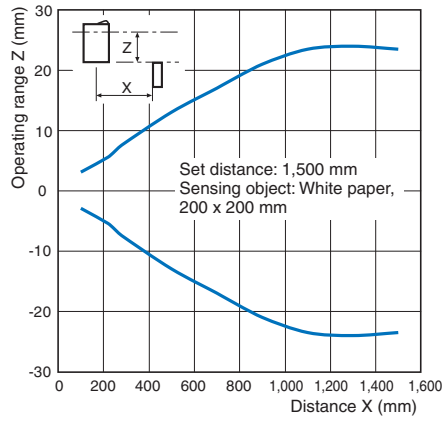

##### Y directions

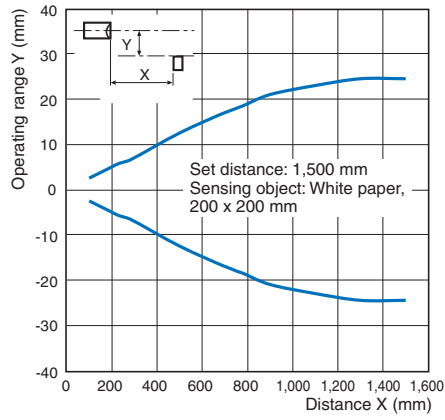

#### E3AS-F1000□

##### Z directions

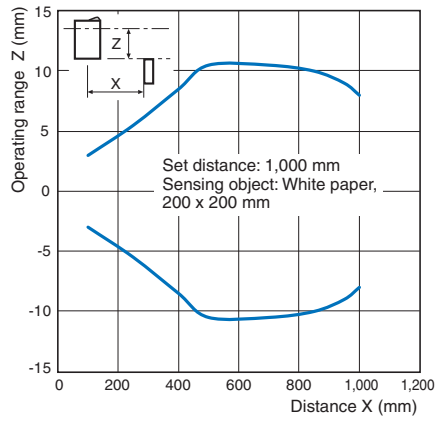

##### Y directions

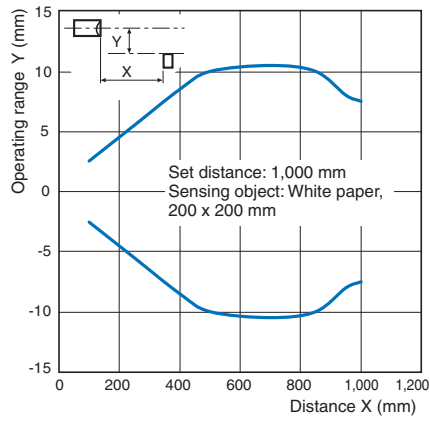

### Spot Diameter vs. Sensing Distance

#### E3AS-F1500□

#### E3AS-F1000□

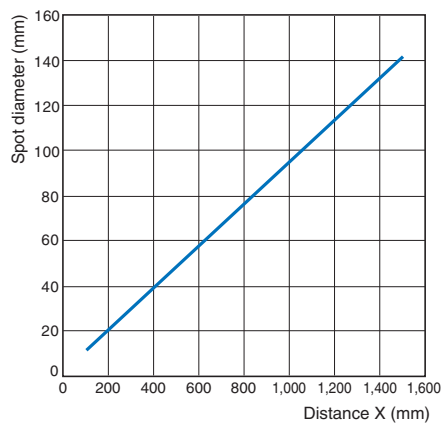

Close-range Characteristics

E3AS-F1500□

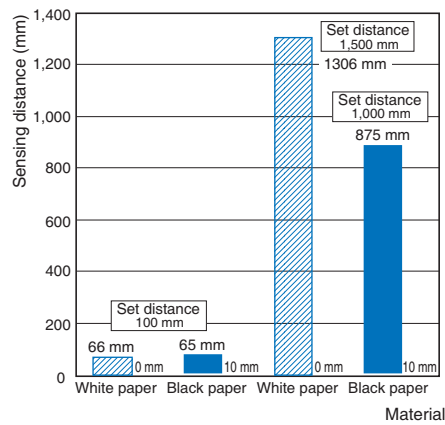

E3AS-F1000□

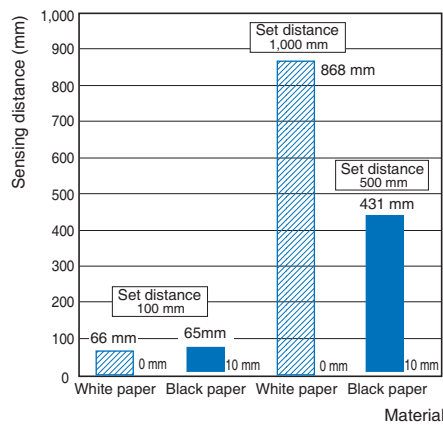

Differential distance for each sensing object Vs. Distance

E3AS-F1500□

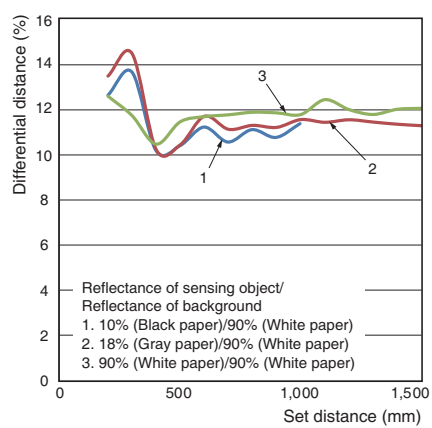

E3AS-F1000□

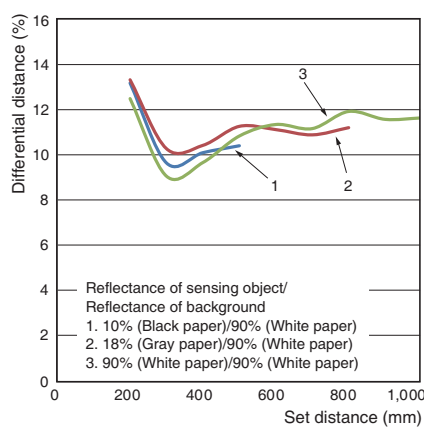

Sensing Object Angle Characteristics

E3AS-F1500□

Vertical

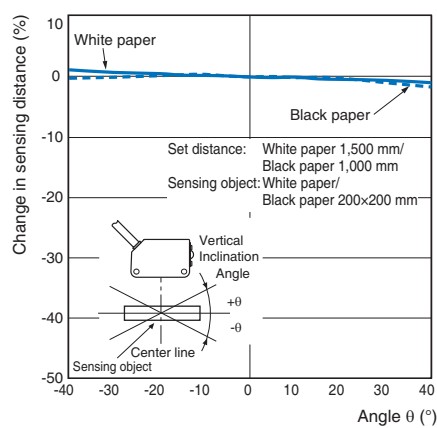

Horizontal

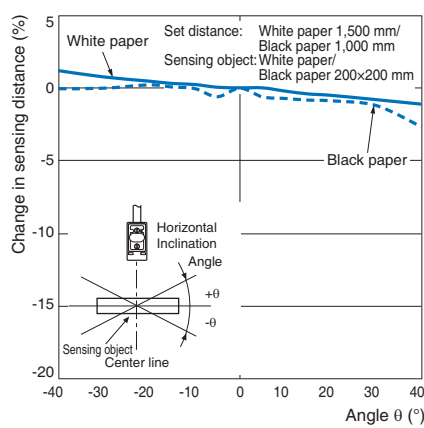

## E3AS-F1000□

### Vertical

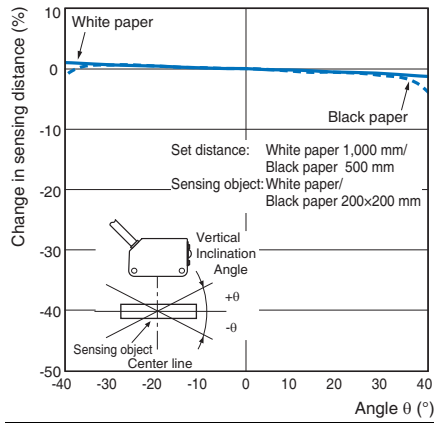

### Horizontal

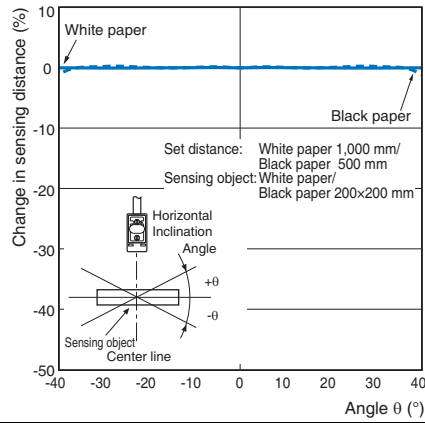

## Sensing Distance vs. Sensing Object Material

### E3AS-F1500□

(Set Distance of 1,500 mm using White Paper)

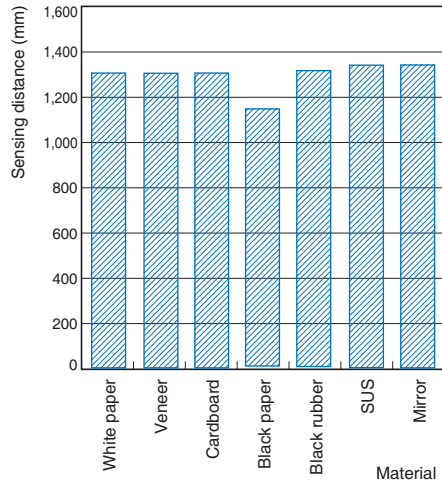

### E3AS-F1000□

(Set Distance of 1,000 mm using White Paper)

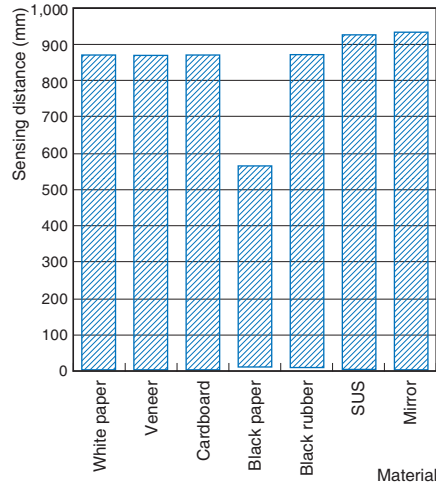

## Sensing Object Size vs. Sensing Distance

### E3AS-F1500□

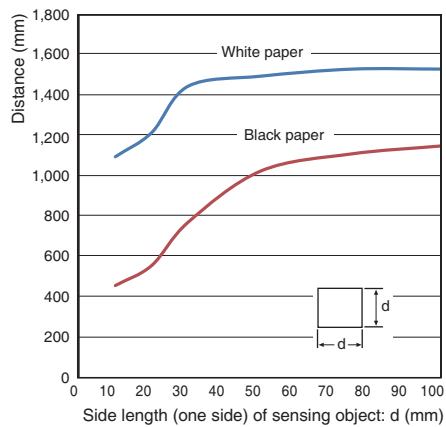

### E3AS-F1000□

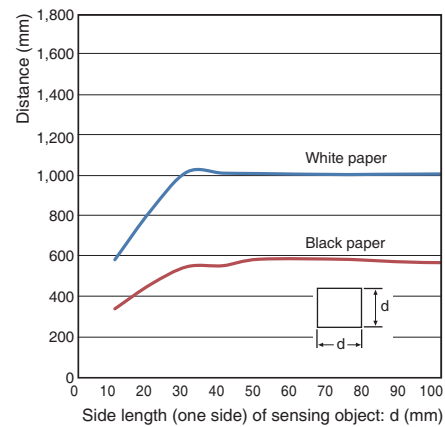

## E3AS-L models

### Operating Range

#### E3AS-L200

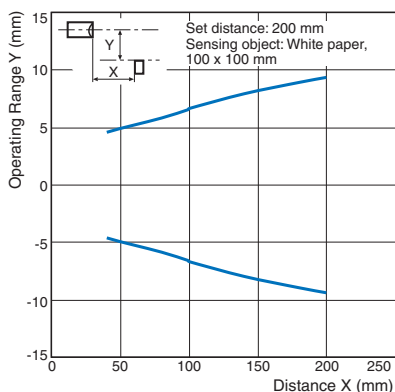

#### E3AS-L80

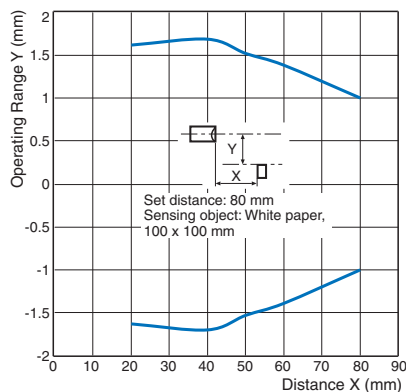

### Spot Diameter vs. Sensing Distance

#### E3AS-L200

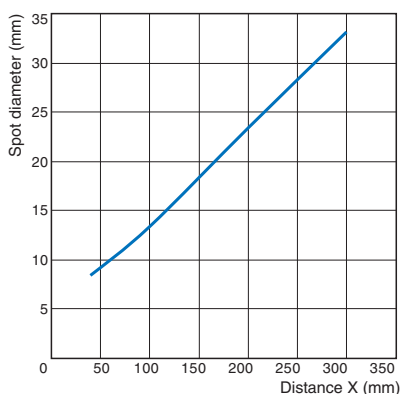

#### E3AS-L80

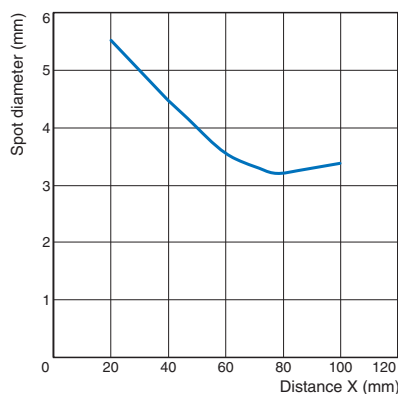

### Close-range Characteristics

#### E3AS-L200

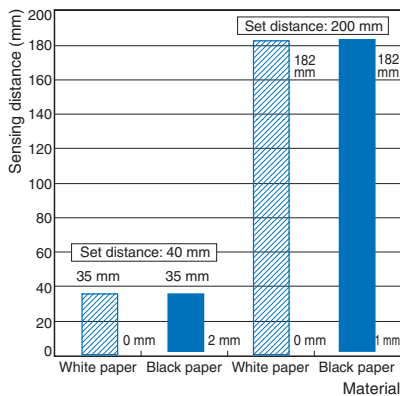

#### E3AS-L80

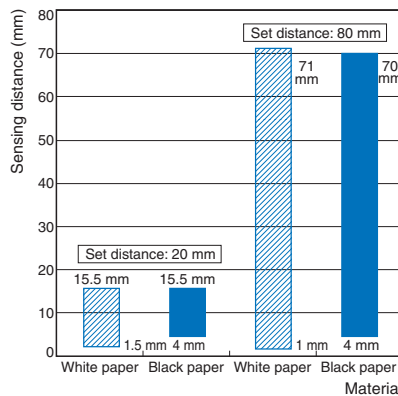

### Differential distance for each sensing object Vs. Distance

#### E3AS-L200

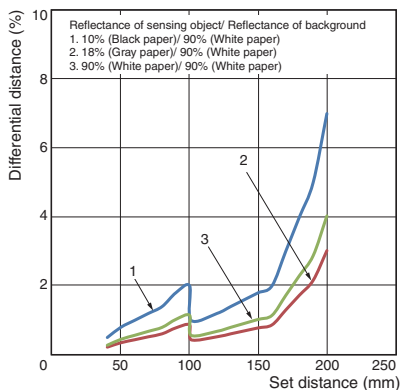

#### E3AS-L80

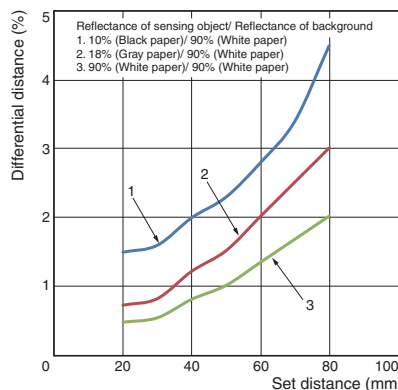

## Sensing Object Angle Characteristics

### E3AS-L200

#### Vertical

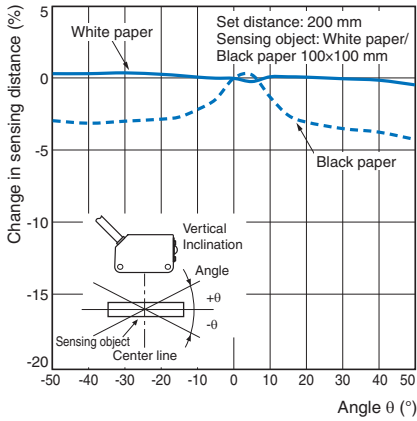

#### Horizontal

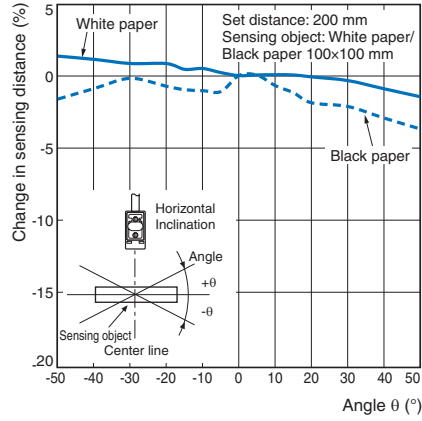

### E3AS-L80

#### Vertical

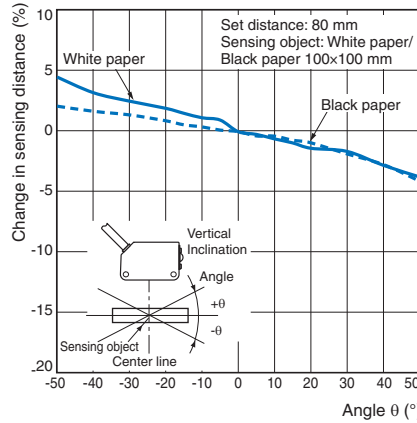

#### Horizontal

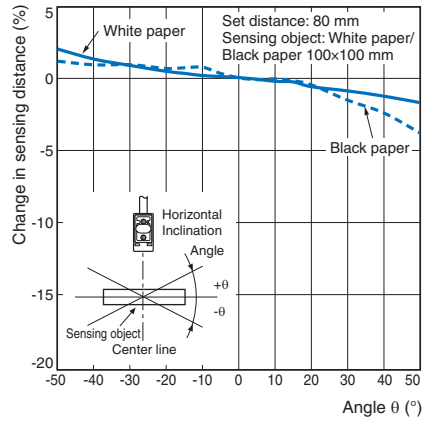

## Sensing Distance vs. Sensing Object Material

### E3AS-L200

(Set Distance of 200 mm using White Paper)

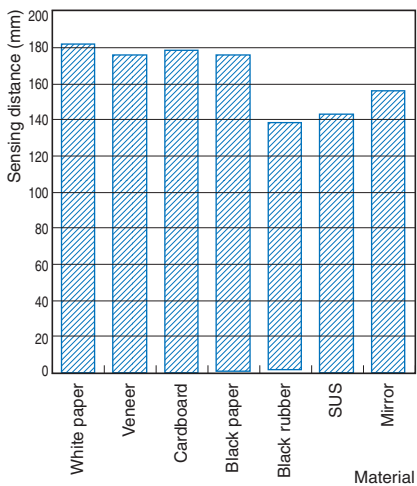

### E3AS-L80

(Set Distance of 80 mm using White Paper)

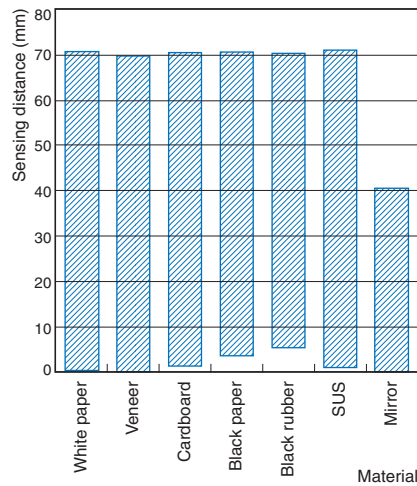



# I/O Circuit Diagrams/ Timing Charts



## E3AS-HL models

### NPN Output

| Model                          | Timing chart                               | Output circuit  |                |     |                |                                  |                 |
|--------------------------------|--|---|----------------|-----|----------------|----------------------------------|-----------------|
| E3AS-HL500□N□<br>E3AS-HL150□N□ | <b>Single Point Mode [Single]</b><br>      | <b>Using Pin2 (white wire) as output</b><br><p>Total load current of the two output routes must be 100 mA or less.</p>  |                |     |                |                                  |                 |
|                                | <b>Window BGS mode [Window BGS]</b><br>    | <b>Using Pin2 (white wire) as external input</b><br>  |                |     |                |                                  |                 |
|                                | <b>Window FGS mode [Window FGS]</b><br>    | <table border="1"> <thead> <tr> <th>External Input</th> <th>NPN</th> </tr> </thead> <tbody> <tr> <td><b>ON time</b></td> <td>0V short-circuit or 1.5V or less</td> </tr> <tr> <td><b>OFF time</b></td> <td>Power supply voltage short-circuit or open</td> </tr> </tbody> </table> <p>Connector Pin Arrangement</p> | External Input | NPN | <b>ON time</b> | 0V short-circuit or 1.5V or less | <b>OFF time</b> |
| External Input                 | NPN  |   |                |     |                |                                  |                 |
| <b>ON time</b>                 | 0V short-circuit or 1.5V or less           |   |                |     |                |                                  |                 |
| <b>OFF time</b>                | Power supply voltage short-circuit or open |   |                |     |                |                                  |                 |

\* The initial value of control output 2 is reverse of control output 1.

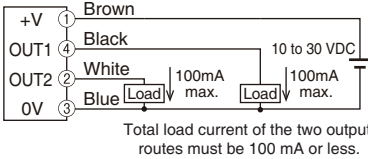
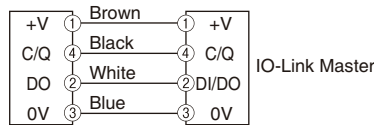
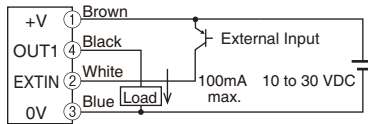
## PNP Output

| Model   | Output circuit   |  |     |         |  |          |                          |
|---|--|--|-----|---------|--|----------|--------------------------|
|   | Standard I/O mode (SIO mode) *1  | IO-Link Communication mode (COM mode) *2   |     |         |  |          |                          |
| E3AS-HL500□□T□<br>E3AS-HL150□□T□  | <p><b>Using Pin2 (white wire) as output</b></p>   | <p><b>Using Pin2 (white wire) as output</b></p>  |     |         |  |          |                          |
|   | <p><b>Using Pin2 (white wire) as external input</b></p>  <table border="1" data-bbox="359 728 821 840"> <thead> <tr> <th>External Input</th> <th>PNP</th> </tr> </thead> <tbody> <tr> <td>ON time</td> <td>Power supply voltage short-circuit or within power supply voltage - 1.5V</td> </tr> <tr> <td>OFF time</td> <td>0V short-circuit or open</td> </tr> </tbody> </table> | External Input   | PNP | ON time | Power supply voltage short-circuit or within power supply voltage - 1.5V | OFF time | 0V short-circuit or open |
| External Input  | PNP  |  |     |         |  |          |                          |
| ON time   | Power supply voltage short-circuit or within power supply voltage - 1.5V   |  |     |         |  |          |                          |
| OFF time  | 0V short-circuit or open   |  |     |         |  |          |                          |
| <p>Connector Pin Arrangement</p> <div style="display: flex; justify-content: space-around;"> <div data-bbox="718 907 869 1041"> <p>M12 Pre-wired Smartclick Connector</p>  </div> <div data-bbox="933 907 1037 1041"> <p>M8 Connector</p>  </div> </div> |  |  |     |         |  |          |                          |

\*1. Standard I/O mode is used as PNP ON/OFF output.

\*2. IO-Link Communication mode is used for communications with the IO-Link Master. C/Q performs IO-Link communications. Sensor output DO performs ON/OFF output.

## Single Point Mode [Single]

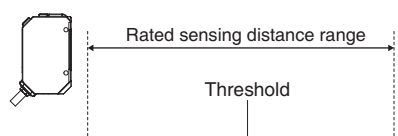
| Timing charts                         |  |                                       |                           |  |  |     |  |                              |     |  |                      |     |  |                     |    |  |                         |     |  |                         |     |  |  |     |  |
|---------------------------------------|--|---------------------------------------|---------------------------|--|--|-----|--|------------------------------|-----|--|----------------------|-----|--|---------------------|----|--|-------------------------|-----|--|-------------------------|-----|--|--|-----|--|
| Output mode                           |   |                                       |                           |  |  |     |  |                              |     |  |                      |     |  |                     |    |  |                         |     |  |                         |     |  |  |     |  |
| Standard I/O mode (SIO mode)          | <table border="0"> <tr> <td>Power/Communication indicator (green)</td> <td>ON</td> <td></td> </tr> <tr> <td></td> <td>OFF</td> <td></td> </tr> <tr> <td>Operation indicator (orange)</td> <td>ON</td> <td></td> </tr> <tr> <td></td> <td>OFF</td> <td></td> </tr> <tr> <td>Control output 1 *2</td> <td>ON</td> <td></td> </tr> <tr> <td></td> <td>OFF</td> <td></td> </tr> <tr> <td>Control output 2 *1, *2</td> <td>ON</td> <td></td> </tr> <tr> <td></td> <td>OFF</td> <td></td> </tr> </table> | Power/Communication indicator (green) | ON                        |  |  | OFF |  | Operation indicator (orange) | ON  |  |                      | OFF |  | Control output 1 *2 | ON |  |                         | OFF |  | Control output 2 *1, *2 | ON  |  |  | OFF |  |
|                                       | Power/Communication indicator (green)  | ON                                    |                           |  |  |     |  |                              |     |  |                      |     |  |                     |    |  |                         |     |  |                         |     |  |  |     |  |
|                                       |  | OFF                                   |                           |  |  |     |  |                              |     |  |                      |     |  |                     |    |  |                         |     |  |                         |     |  |  |     |  |
|                                       | Operation indicator (orange)   | ON                                    |                           |  |  |     |  |                              |     |  |                      |     |  |                     |    |  |                         |     |  |                         |     |  |  |     |  |
|                                       | OFF  |                                       |                           |  |  |     |  |                              |     |  |                      |     |  |                     |    |  |                         |     |  |                         |     |  |  |     |  |
| Control output 1 *2                   | ON   |                                       |                           |  |  |     |  |                              |     |  |                      |     |  |                     |    |  |                         |     |  |                         |     |  |  |     |  |
|                                       | OFF  |                                       |                           |  |  |     |  |                              |     |  |                      |     |  |                     |    |  |                         |     |  |                         |     |  |  |     |  |
| Control output 2 *1, *2               | ON   |                                       |                           |  |  |     |  |                              |     |  |                      |     |  |                     |    |  |                         |     |  |                         |     |  |  |     |  |
|                                       | OFF  |                                       |                           |  |  |     |  |                              |     |  |                      |     |  |                     |    |  |                         |     |  |                         |     |  |  |     |  |
| IO-Link Communication mode (COM mode) | <table border="0"> <tr> <td>Power/Communication indicator (green)</td> <td>Flashing (1 second cycle)</td> <td></td> </tr> <tr> <td></td> <td>ON</td> <td></td> </tr> <tr> <td></td> <td>OFF</td> <td></td> </tr> <tr> <td>Communication output</td> <td>1</td> <td></td> </tr> <tr> <td></td> <td>0</td> <td></td> </tr> <tr> <td>Control output 2 *1, *2</td> <td>ON</td> <td></td> </tr> <tr> <td></td> <td>OFF</td> <td></td> </tr> </table>  | Power/Communication indicator (green) | Flashing (1 second cycle) |  |  | ON  |  |                              | OFF |  | Communication output | 1   |  |                     | 0  |  | Control output 2 *1, *2 | ON  |  |                         | OFF |  |  |     |  |
|                                       | Power/Communication indicator (green)  | Flashing (1 second cycle)             |                           |  |  |     |  |                              |     |  |                      |     |  |                     |    |  |                         |     |  |                         |     |  |  |     |  |
|                                       |  | ON                                    |                           |  |  |     |  |                              |     |  |                      |     |  |                     |    |  |                         |     |  |                         |     |  |  |     |  |
|                                       |  | OFF                                   |                           |  |  |     |  |                              |     |  |                      |     |  |                     |    |  |                         |     |  |                         |     |  |  |     |  |
| Communication output                  | 1  |                                       |                           |  |  |     |  |                              |     |  |                      |     |  |                     |    |  |                         |     |  |                         |     |  |  |     |  |
|                                       | 0  |                                       |                           |  |  |     |  |                              |     |  |                      |     |  |                     |    |  |                         |     |  |                         |     |  |  |     |  |
| Control output 2 *1, *2               | ON   |                                       |                           |  |  |     |  |                              |     |  |                      |     |  |                     |    |  |                         |     |  |                         |     |  |  |     |  |
|                                       | OFF  |                                       |                           |  |  |     |  |                              |     |  |                      |     |  |                     |    |  |                         |     |  |                         |     |  |  |     |  |

- \*1. The initial value of control output 2 is reverse of control output 1.
- \*2. The timer function of the control output can be set up by the IO-Link communications. (It is able to select ON delay, OFF delay, or one-shot function and select a timer time of 1 to 9,999 ms (T).)

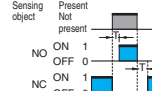
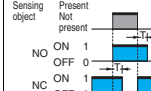
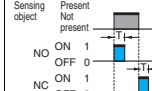
| ON delay   | OFF delay   | One Shot  |
|--|---|---|
|  |  |  |

Please contact your OMRON sales representative regarding the IO-Link setup file (IODD file).

Window BGS mode [Window BGS]

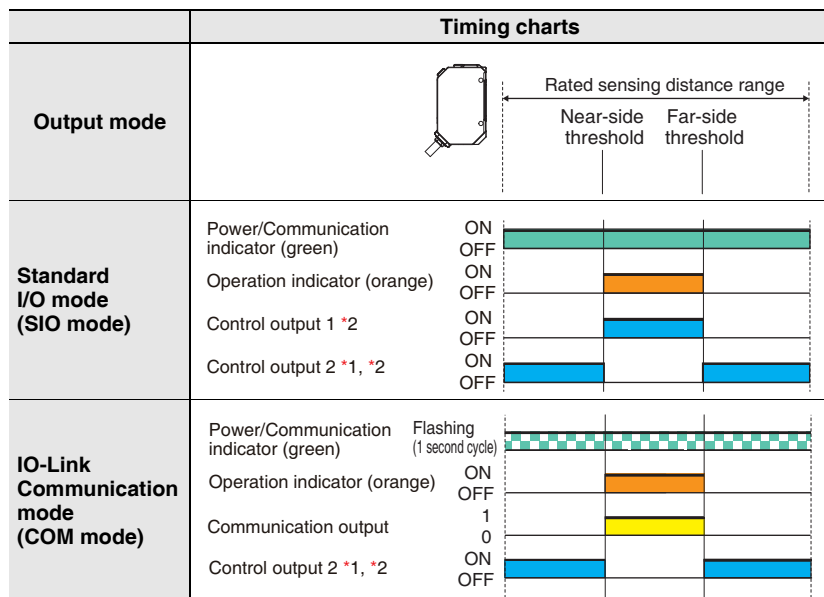

- \*1. The initial value of control output 2 is reverse of control output 1.
- \*2. The timer function of the control output can be set up by the IO-Link communications. (It is able to select ON delay, OFF delay, or one-shot function and select a timer time of 1 to 9,999 ms (T).)

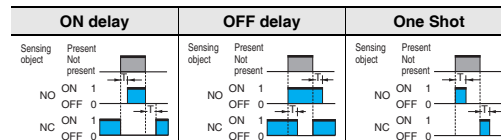

Please contact your OMRON sales representative regarding the IO-Link setup file (IODD file).

Window FGS mode [Window FGS]

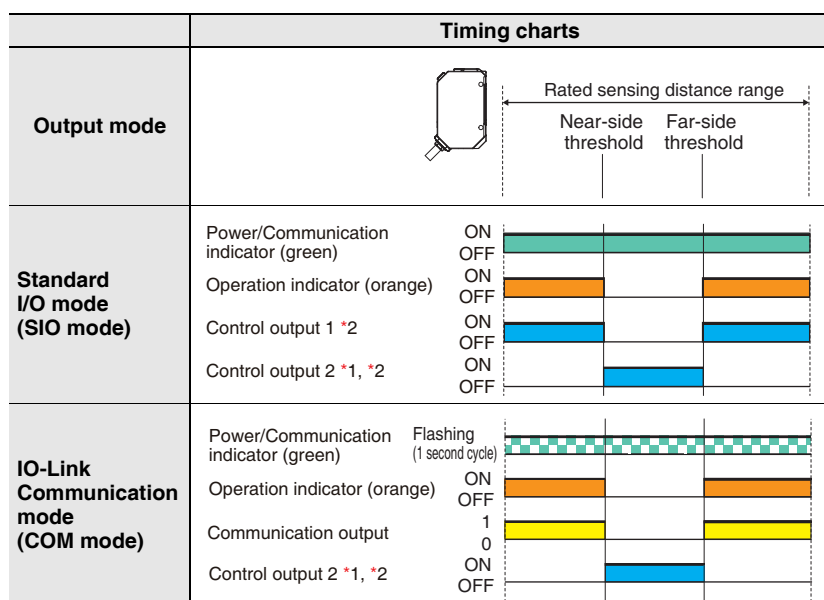

- \*1. The initial value of control output 2 is reverse of control output 1.
- \*2. The timer function of the control output can be set up by the IO-Link communications. (It is able to select ON delay, OFF delay, or one-shot function and select a timer time of 1 to 9,999 ms (T).)

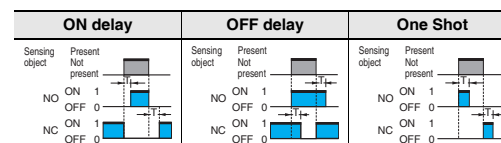

Please contact your OMRON sales representative regarding the IO-Link setup file (IODD file).

**Note:** Shown above are the factory settings. Refer to the index list for the default settings at time of shipment from factory. PNP/COM output logic can be reversed by IO-Link communication. The operation indicator (orange) lights up when control output 1 is ON or communication output is 1.

Nomenclature

E3AS-HL500□  
E3AS-HL150□

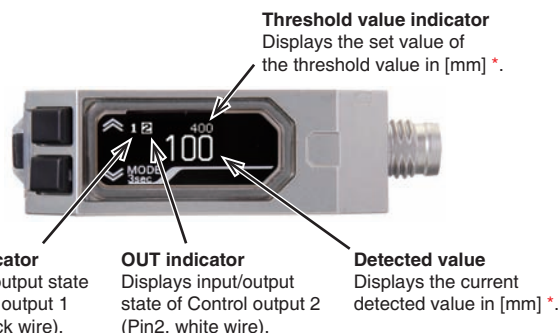
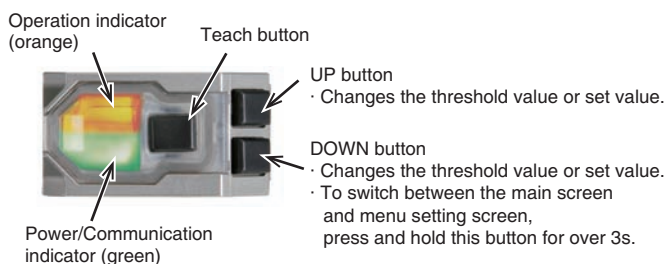

\* The indicators work differently depending on sensor status.

\* Reference value

## E3AS-F models

### NPN Output

| Model                          | Timing chart  | Output circuit   |
|--------------------------------|---|--|
| E3AS-F1500□N□<br>E3AS-F1000□N□ | <p>Stability&amp;Communication indicator (green)<br/>Operation indicator (orange)<br/>Control output 1<br/>Control output 2 *</p> | <p>Connector Pin Arrangement</p> <p>M12 Pre-wired Smartclick Connector      M8 Connector</p> |

\* The initial value of control output 2 is reverse of control output 1.

### PNP Output

| Model                          | Output circuit   |   |
|--------------------------------|--|---|
|                                | Standard I/O mode (SIO mode) *1  | IO-Link Communication mode (COM mode) *2  |
| E3AS-F1500□T□<br>E3AS-F1000□T□ | <p>Connector Pin Arrangement</p> <p>M12 Pre-wired Smartclick Connector      M8 Connector</p> | <p>IO-Link Master Unit</p> <p>Connector Pin Arrangement</p> <p>M12 Pre-wired Smartclick Connector      M8 Connector</p> |

\*1. Standard I/O mode is used as PNP ON/OFF output.

\*2. IO-Link Communication mode is used for communications with the IO-Link Master. C/Q performs IO-Link communications. Sensor output DO performs ON/OFF output.

| Output mode                           | Timing charts  |
|---------------------------------------|--|
| Standard I/O mode (SIO mode)          | <p>Stability&amp;Communication indicator (green)<br/>Operation indicator (orange)<br/>Control output 1 *2<br/>Control output 2 *1, *2</p>                            |
| IO-Link Communication mode (COM mode) | <p>Stability&amp;Communication indicator (green) Flashing (1 second cycle)<br/>Operation indicator (orange)<br/>Communication output<br/>Control output 2 *1, *2</p> |

\*1. The initial value of control output 2 is reverse of control output 1.

\*2. The timer function of the control output can be set by the IO-Link communications. (It is able to select ON delay, OFF delay, or one-shot function and select a timer time of 1 to 9,999 ms (T).)

| ON delay       |             | OFF delay      |             | One Shot       |             |
|----------------|-------------|----------------|-------------|----------------|-------------|
| Sensing object | Present     | Sensing object | Present     | Sensing object | Present     |
|                | Not present |                | Not present |                | Not present |
| NO             | ON 1        | NO             | ON 1        | NO             | ON 1        |
|                | OFF 0       |                | OFF 0       |                | OFF 0       |
| NC             | ON 1        | NC             | ON 1        | NC             | ON 1        |
|                | OFF 0       |                | OFF 0       |                | OFF 0       |

Please contact your OMRON sales representative regarding the IO-Link setup file (IODD file).

Note: Shown above are the factory settings. Refer to the index list for the default settings at time of shipment from factory.

PNP/COM output logic can be reversed by IO-Link communication.

The operation indicator (orange) lights up when control output 1 is ON or communication output is 1.

## Nomenclature

E3AS-F1500□  
E3AS-F1000□

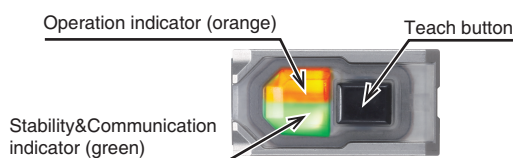

Note: The indicators work differently depending on sensor status.

## E3AS-L models

### NPN Output

| Model    | Timing chart   | Output circuit   |
|----------|--|--|
| E3AS-L□N | <p>Stability&amp;Communication indicator (green) *1</p> <p>Operation indicator (orange)</p> <p>Control output 1</p> <p>Control output 2 *2</p> | <p>Connector Pin Arrangement</p> <p>M12 Pre-wired Smartclick Connector</p> <p>M8 Connector</p> |

\*1. Turns off when there is insufficient margin for incident light. In that case, place the workpiece closer to ensure sufficient receiving light intensity.  
 \*2. The initial value of control output 2 is reverse of control output 1.

### PNP Output

| Model    | Output circuit   |   |
|----------|--|---|
|          | Standard I/O mode (SIO mode) *1  | IO-Link Communication mode (COM mode) *2  |
| E3AS-L□T | <p>Connector Pin Arrangement</p> <p>M12 Pre-wired Smartclick Connector</p> <p>M8 Connector</p> | <p>IO-Link Master Unit</p> <p>Connector Pin Arrangement</p> <p>M12 Pre-wired Smartclick Connector</p> <p>M8 Connector</p> |

\*1. Standard I/O mode is used as PNP ON/OFF output.  
 \*2. IO-Link Communication mode is used for communications with the IO-Link Master. C/Q performs IO-Link communications. Sensor output DO performs ON/OFF output.

| Output mode                           | Timing charts                                |                           |
|---------------------------------------|--|---------------------------|
|                                       |  | Threshold                 |
| Standard I/O mode (SIO mode)          | Stability&Communication indicator (green) *1 | ON OFF                    |
|                                       | Operation indicator (orange)                 | ON OFF                    |
|                                       | Control output 1 *3                          | ON OFF                    |
|                                       | Control output 2 *2                          | ON OFF                    |
| IO-Link Communication mode (COM mode) | Stability&Communication indicator (green)    | Flashing (1 second cycle) |
|                                       | Operation indicator (orange)                 | ON OFF                    |
|                                       | Communication output                         | 1 0                       |
|                                       | Control output 2 *2                          | ON OFF                    |

\*1. Turns off when there is insufficient margin for incident light. In that case, place the workpiece closer to ensure sufficient receiving light intensity.  
 \*2. The initial value of control output 2 is reverse of control output 1.  
 \*3. The timer function of the control output 2 can be set up by the IO-Link communications. (It is able to select ON delay, OFF delay, or one-shot function and select a timer time of 1 to 9,999 ms (T).)

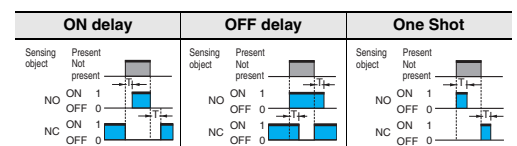

Please contact your OMRON sales representative regarding the IO-Link setup file (IODD file).

**Note:** Shown above are the factory settings. Refer to the index list for the default settings at time of shipment from factory.  
 PNP/COM output logic can be reversed by IO-Link communication.  
 The operation indicator (orange) lights up when control output 1 is ON or communication output is 1.

## Nomenclature

E3AS-L200□  
 E3AS-L80□

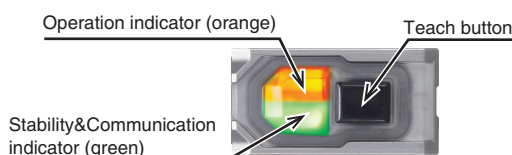



Note: The indicators work differently depending on sensor status.

# E3AS Series

## Safety Precautions

Be sure to read the precautions for all models in the website at: <http://www.ia.omron.com/>.

### Warning Indications

|  |  |
|--|--|
|  <b>WARNING</b> | <b>Warning level</b><br>Indicates a potentially hazardous situation which, if not avoided, will result in minor or moderate injury, or may result in serious injury or death. Additionally there may be significant property damage. |
|  <b>CAUTION</b> | <b>Caution level</b><br>Indicates a potentially hazardous situation which, if not avoided, may result in minor or moderate injury or in property damage.   |
| <b>Precautions for Safe Use</b>  | Supplementary comments on what to do or avoid doing, to use the product safely.  |
| <b>Precautions for Correct Use</b>   | Supplementary comments on what to do or avoid doing, to prevent failure to operate, malfunction or undesirable effect on product performance.  |

### Meaning of Product Safety Symbols

|   |   |
|---|---|
|    | <b>General prohibition</b><br>Indicates the instructions of unspecified prohibited action   |
|    | <b>Caution, fire</b><br>Indicates the possibility of fires under specific conditions.   |
|   | <b>General caution</b><br>Indicates unspecified general alert.  |
|  | <b>Caution, explosion</b><br>Indicates the possibility of explosion under specific conditions                                       |
|  | <b>Laser Caution</b><br>Indicates information related to laser safety   |
|  | <b>Disassembly prohibited</b><br>Prohibit the disassembly of a device because of the possibility of injuries due to electric shock. |

### **WARNING**

This product is not designed or rated for ensuring safety of persons either directly or indirectly. Do not use it for such purposes. 

Do not use it exceeding the rated voltage. There is a possibility of failure and fire. 

### **CAUTION**

Its component may be damaged and/or degree of protection may be degraded. Please do not apply high pressure water intensively at one place during cleaning. 

Never use the product with an AC power supply. Otherwise, explosion may result. 

### E3AS-HL and E3AS-F models

#### To safely use laser products

### **WARNING**

Do not expose your eyes to the laser beam either directly or indirectly (i.e., after reflection from a mirror or shiny surface). The laser beam has a high power density and exposure may result in loss of sight. 

Do not disassemble this product. Doing so may cause exposure to the built-in light source which can damage eyes and skin. Never disassemble it. 

Laser safety measures for laser equipment are stipulated by the country of use. Follow the instructions described below categorized in four cases.

#### 1. Usage in Japan

The JIS C6802:2014 standard stipulates the safety precautions that users must take according to the class of the laser product. This product is classified into class 1 defined by this standard.

#### 2. Usage in U.S.

This product is subjected to the U.S. FDA (Food and Drug Administration) laser regulations. This product is classified into Class 1 by the IEC 60825-1:2014 standard according to the regulations of Laser Notice No.56 of the FDA standard. This product is already reported to CDRH (Center for Devices and Radiological Health).

Accession Number: 1920014-001

When using a device equipped with the product in the U.S., attach an FDA certification label near the sensor mounted on customer equipment.

FDA certification label

This laser product complies with 21 CFR 1040.10 and 1040.11 except for deviations pursuant to Laser Notice No. 50, dated June 24, 2007  
OMRON Corporation  
Shikokji Horikawa, Shimogyo-ku,  
Kyoto 600-8530 JAPAN  
Place of manufacture:  
Shanghai Factory, OMRON Corp.  
Manufactured in

#### 3. Usage in China

This product is classified into Class 2 by the GB7247.1:2012 (IEC60825-1:2007) standard.

When using a device equipped with the product in China, attach a Warning label near the sensor mounted on customer equipment.

Warning label



#### 4. Usage in countries other than U.S. and China

This product is classified into Class 1 by the IEC/EN 60825-1:2014 standard.

### Precautions for Safe Use

The following precautions must be observed to ensure safe operation.

1. Do not reverse the power supply connection or connect to an AC current.
2. Do not short the load.
3. Be sure that before making supply the supply voltage is less than the maximum rated supply voltage (30 VDC).
4. Do not use the product in environments subject to flammable or explosive gases.
5. Do not use the product under a chemical or an oil environment without prior evaluation.
6. Do not attempt to modify the product.
7. Do not touch the metal surface with your bare hands when the temperature is low. Touching the surface may result in a cold burn.
8. Burn injury may occur. The product surface temperature rises depending on application conditions, such as the ambient temperature and the power supply voltage. Attention must be paid during operation or cleaning.

### Precautions for Correct Use

1. Do not hit the product using a hammer for installation.
2. The product must be installed with the specified torque or less. For M8 connector, the proper tightening torque is from 0.3 to 0.4 N·m. In case of M12 smartclick connector, manually tighten the connector.
3. Tightening torque for the mounting hole is 0.6 N·m or less (M3 screw).
4. Do not use the product in any atmosphere or environment that exceeds the ratings.
5. Output pulses may occur when the power supply is turned OFF. We recommend that you turn OFF the power supply to the load or load line first.
6. Use an extension cable less than 100 m long for Standard I/O mode and less than 20 m for IO-Link Communication mode.
7. Do not pull on the cable with excessive strength.
8. Be sure to turn off the power supply when connecting or disconnecting the cable.
9. Please wait for at least 600 ms (E3AS-HL), 500 ms (E3AS-F), 100 ms (E3AS-L) after turning on the product's power until it is available for use.
10. Though this is type IP67, do not use in the water, rain or outdoors.
11. If the Sensor wiring is placed in the same conduits or ducts as high-voltage or high-power lines, inductive noise may cause malfunction or damage. Wire the cables separately or use a shielded cable.
12. Do not use the product in locations subject to direct sunlight.
13. Do not use the product where humidity is high and dew condensation may occur.
14. Do not use the product where corrosive gases may exist.
15. If high-pressure washing water and so on hits the button, it might lead to malfunctioning. So, consider use of the key lock function.
16. Do not apply high-pressure washing water directly to the sensor's light emitting / receiving surface from a short distance. As the antifouling feature may be impaired, keep a sufficient distance from the light emitting / receiving surface.
17. Do not use the product at a location subject to shock or vibration.
18. To use a commercially available switching regulator, FG (frame ground) must be grounded.
19. Do not use organic solvents (e.g. paint thinner and alcohol) for cleaning. Otherwise optical properties and protective structure may deteriorate.
20. Be sure to check the influence caused by surrounding environments such as background objects and LED lighting before using the product.
21. Do not exceed 100,000 writing operations of the EEPROM (non-volatile memory). Setting information is written to the EEPROM when a threshold value change, teaching, or zero reset is executed.
22.  Please dispose in accordance with applicable regulations.



# E3AS Series

## Dimensions

(Unit: mm)

Tolerance class IT16 applies to dimensions in this data sheet unless otherwise specified.

### Sensors

#### Pre-wired Models/Pre-wired Connector Models

E3AS-HL500□ (-M1TJ)

E3AS-HL150□ (-M1TJ)

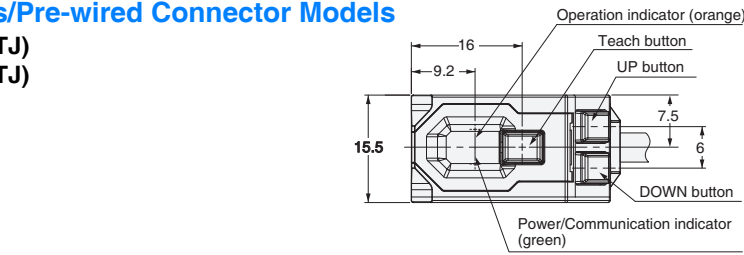

**Pre-wired Connector Models**  
E3AS-HL500□-M1TJ  
E3AS-HL150□-M1TJ

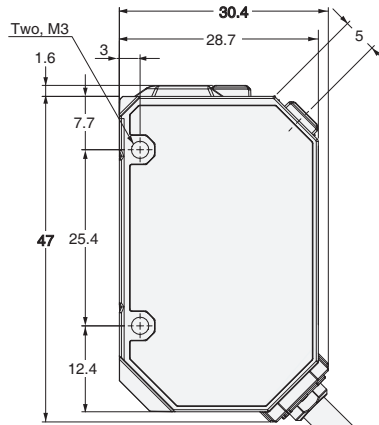
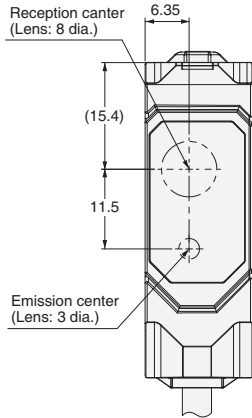
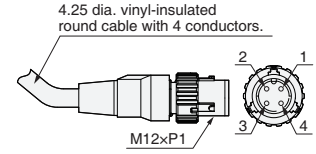

4.25 dia. vinyl-insulated round cable with 4 conductors  
(Conductor cross section: 0.3 mm<sup>2</sup>,  
Insulator diameter: 1.05 mm),  
Standard length: 2 m

**Minimum bending radius/unbendable length of cord**

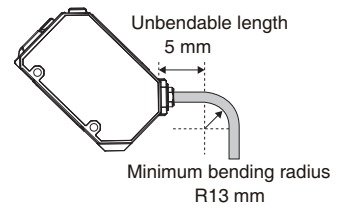

#### Connector Models

E3AS-HL500□ M3

E3AS-HL150□ M3

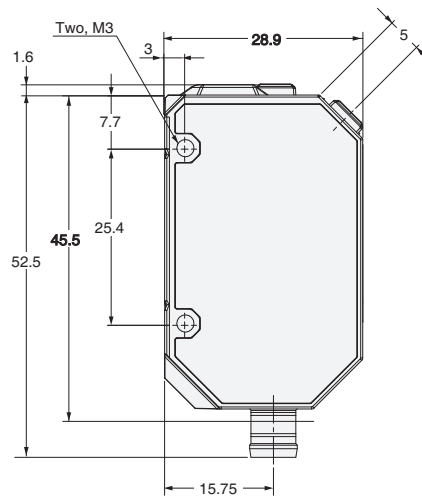
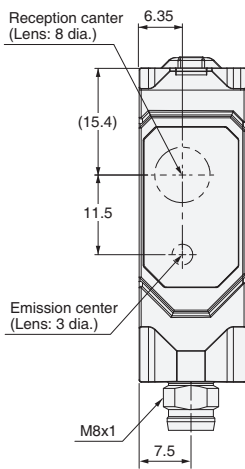
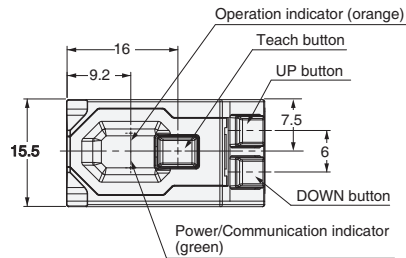



Pre-wired Models/Pre-wired Connector Models

E3AS-F1500□ (-M1TJ)  
E3AS-F1000□ (-M1TJ)

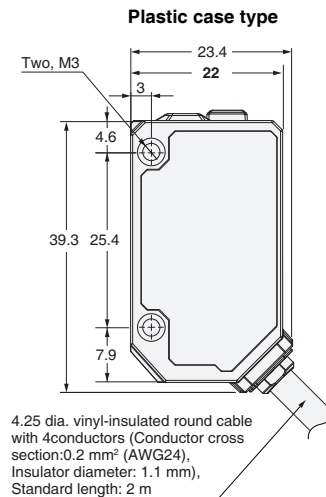
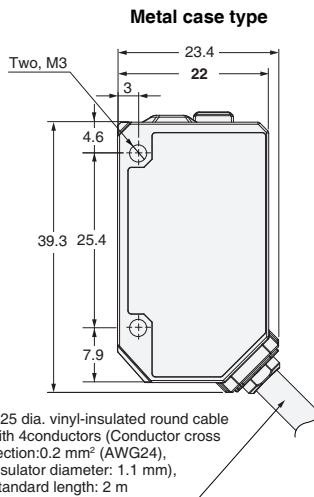
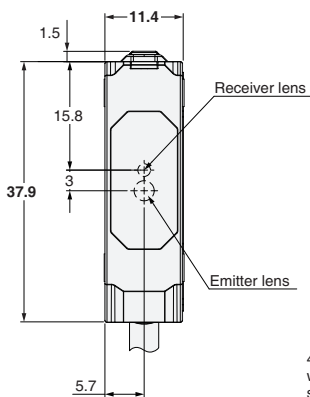
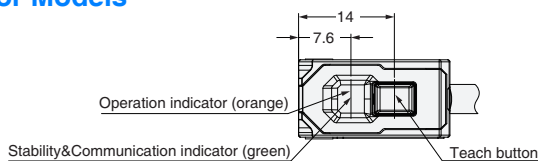

Minimum bending radius/unbendable length of cord

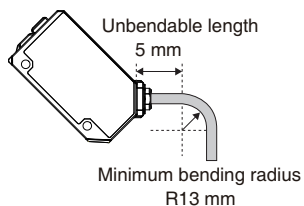

M12 Pre-wired Smartclick Connector type  
E3AS-F1500□-M1TJ/E3AS-F1000□-M1TJ

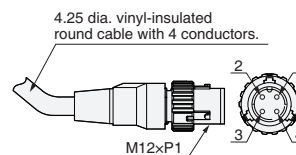

Connector Models

E3AS-F1500□ M3  
E3AS-F1000□ M3

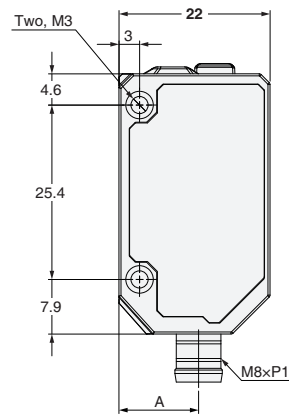
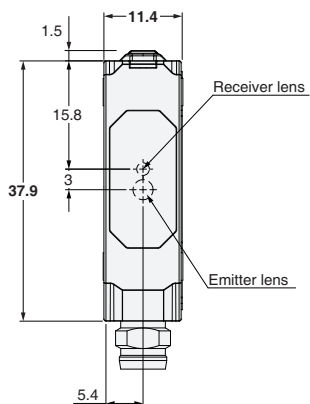
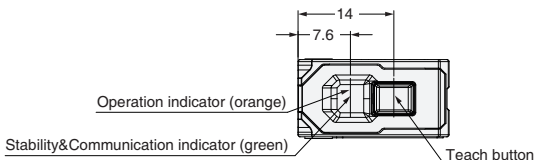

A:  
Metal case type (E3AS-F□M□ M3) :9.6mm  
Plastic case type (E3AS-F□P□ M3) :11.6mm

# E3AS Series

## Pre-wired Models/Pre-wired Connector Models

E3AS-L200□ (-M1TJ)

E3AS-L80□ (-M1TJ)

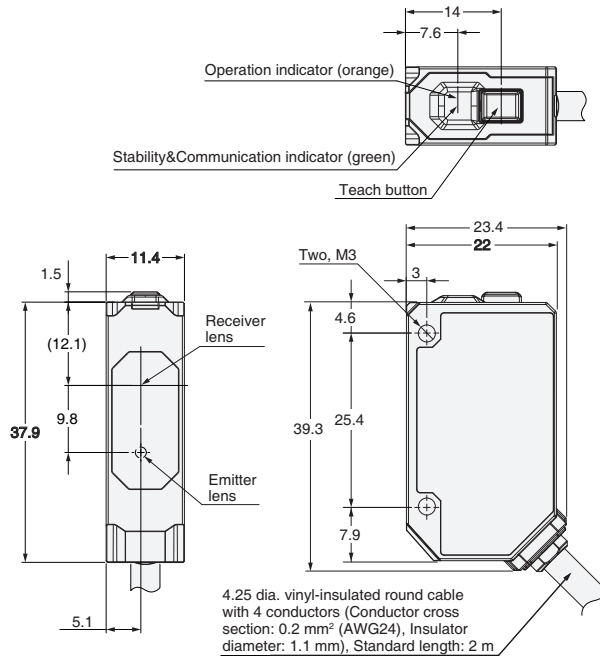

M12 Pre-wired Smartclick Connector type  
E3AS-L200□-M1TJ/E3AS-L80□-M1TJ

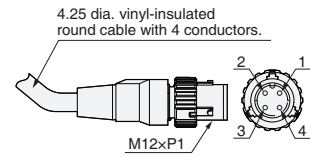

Minimum bending radius/unbendable length of cord

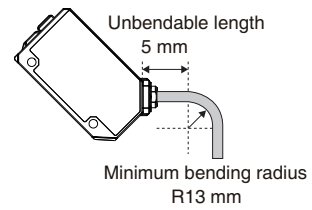

## Connector Models

E3AS-L200□ M3

E3AS-L80□ M3

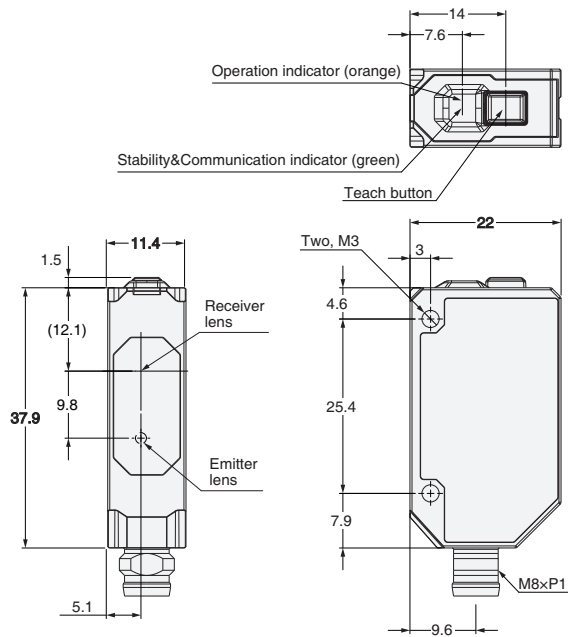

## Accessories (Sold Separately)

### Mounting Brackets

For E3AS-HL models

#### E39-L221

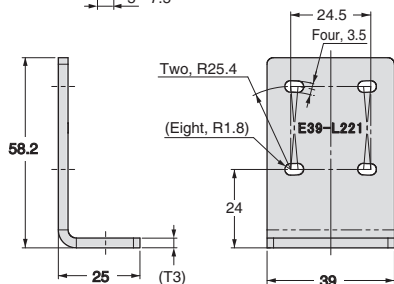
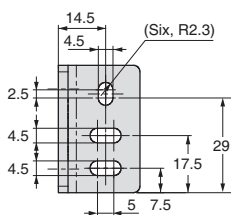

Photoelectric Sensor  
Accessory are installed  
(Example of E3AS-HL500□)

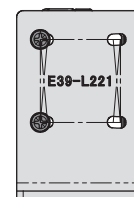
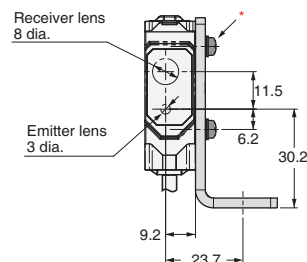
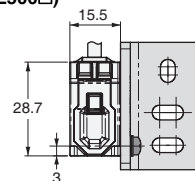

Material: Stainless steel (SUS304)

\* Accessories

2-M3-L10 Cross Recessed Pan Head Screws (Attached to SW+JIS W)

#### E39-L222

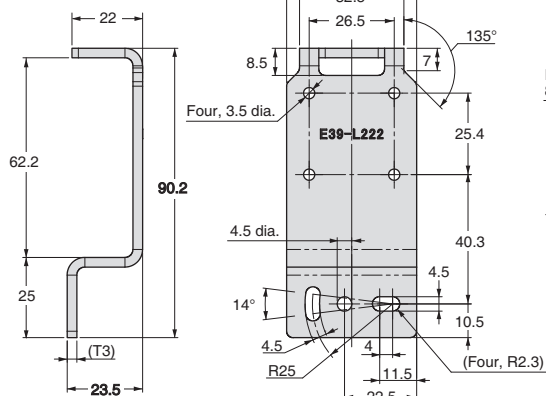
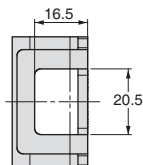

Photoelectric Sensor  
Accessory are installed  
(Example of E3AS-HL500□)

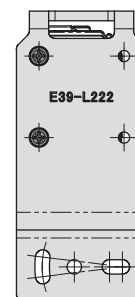
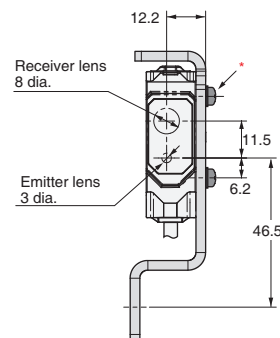
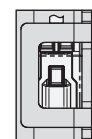

Material: Stainless steel (SUS304)

\* Accessories

2-M3-L10 Cross Recessed Pan Head Screws (Attached to SW+JIS W)

#### E39-L223

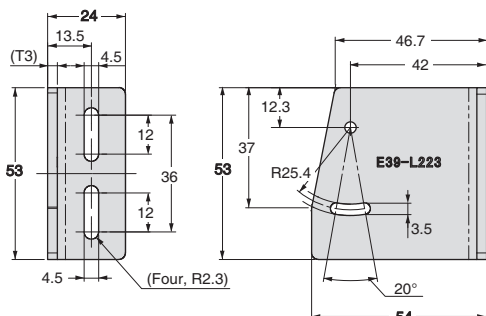

Photoelectric Sensor  
Accessory are installed  
(Example of E3AS-HL500□)

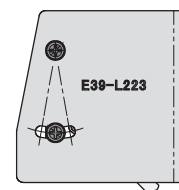
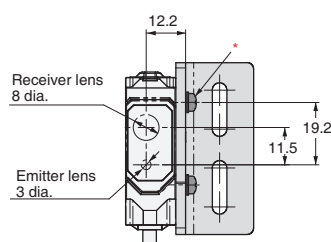

Material: Stainless steel (SUS304)

\* Accessories

2-M3-L10 Cross Recessed Pan Head Screws (Attached to SW+JIS W)

# E3AS Series

## E39-L224

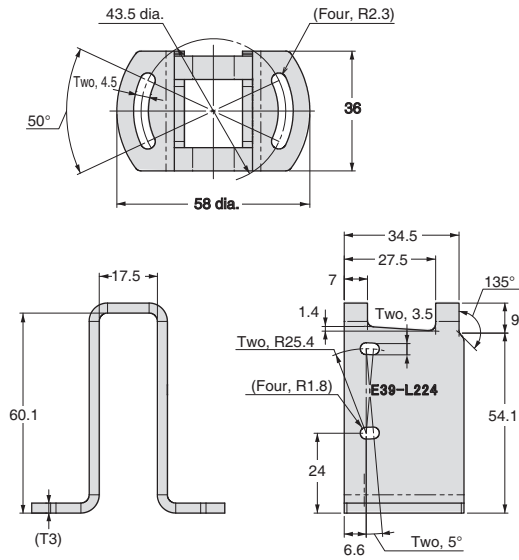

Photoelectric Sensor  
Accessory are installed  
(Example of E3AS-HL500□)

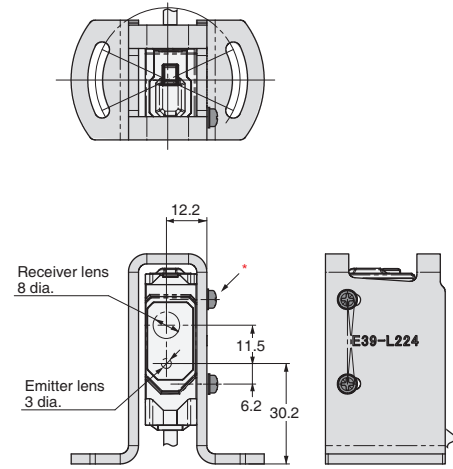

Material: Stainless steel (SUS304)

\* Accessories  
2-M3-L10 Cross Recessed Pan Head Screws (Attached to SW+JIS W)

## E39-L231

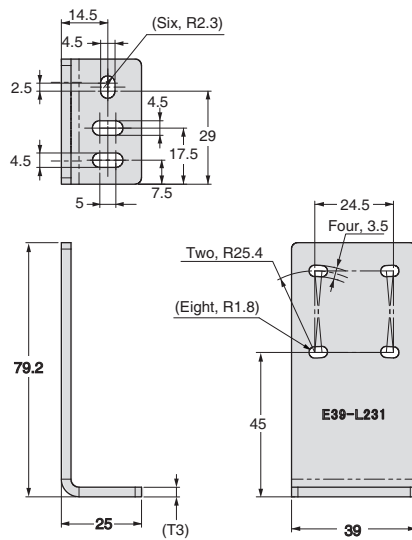

Photoelectric Sensor  
Accessory are installed  
(Example of E3AS-HL500□)

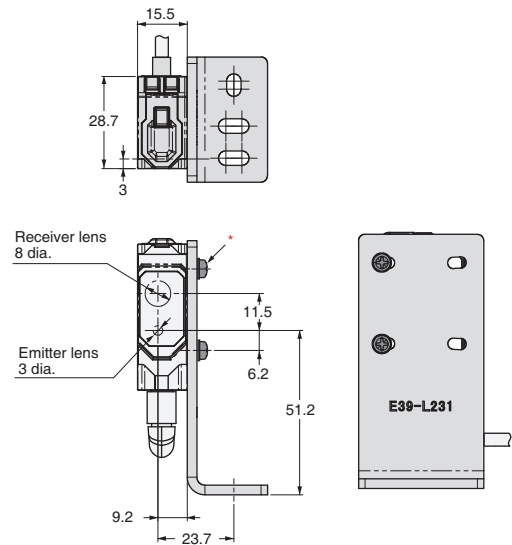

Material: Stainless steel (SUS304)

\* Accessories  
2-M3-L10 Cross Recessed Pan Head Screws (Attached to SW+JIS W)

E39-L232

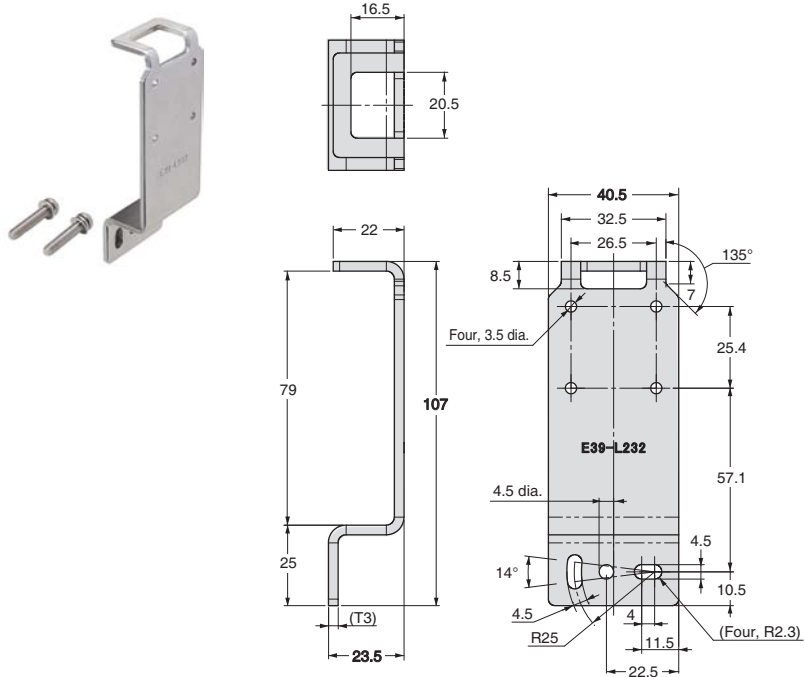

Photoelectric Sensor  
Accessory are installed  
(Example of E3AS-HL500□)

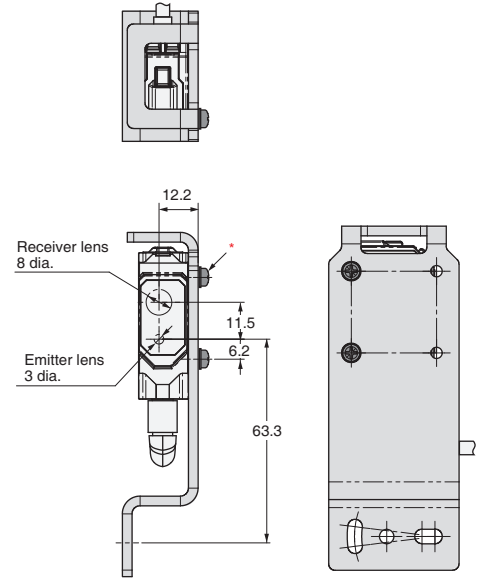

Material: Stainless steel (SUS304)  
\* Accessories  
2-M3-L10 Cross Recessed Pan Head Screws (Attached to SW+JIS W)

E39-L234

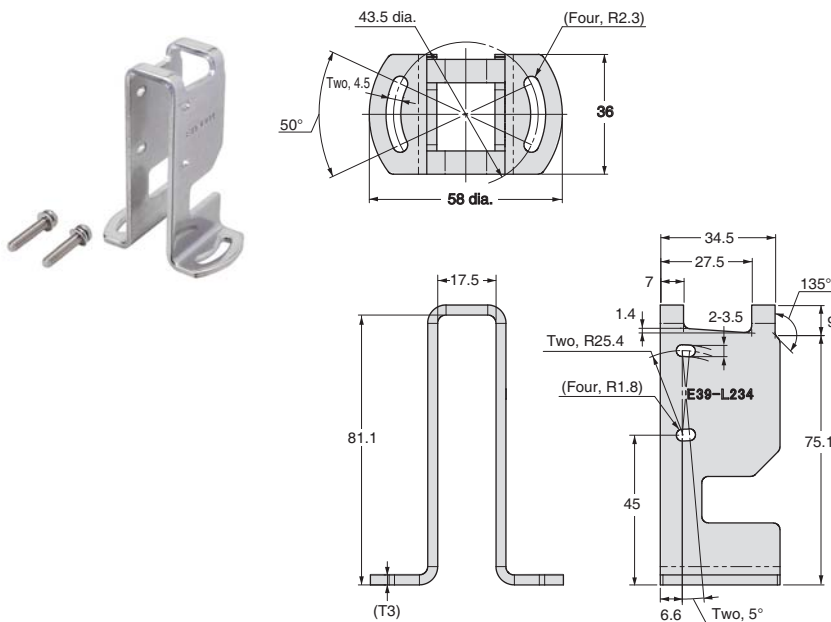

Photoelectric Sensor  
Accessory are installed  
(Example of E3AS-HL500□)

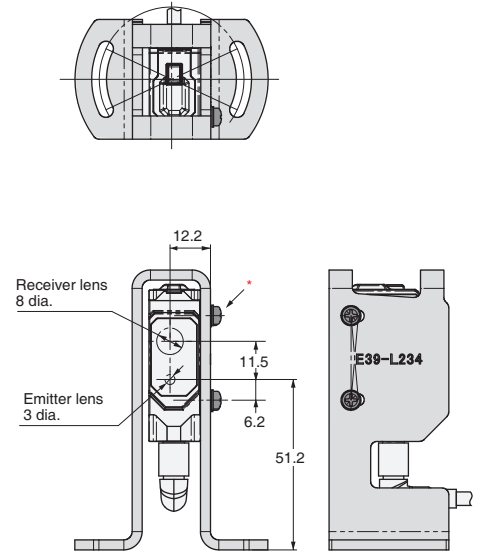

Material: Stainless steel (SUS304)  
\* Accessories  
2-M3-L10 Cross Recessed Pan Head Screws (Attached to SW+JIS W)

# E3AS Series

## E39-E19

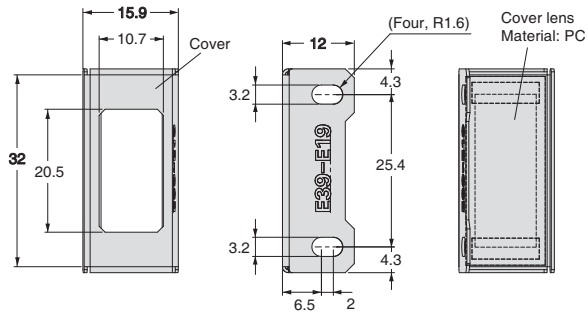
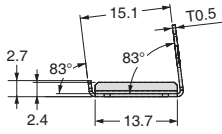

Photoelectric Sensor  
Accessory are installed  
(Example of E3AS-HL500□)

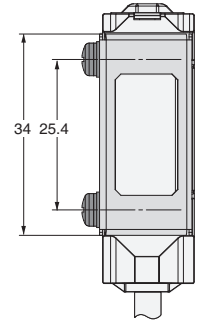
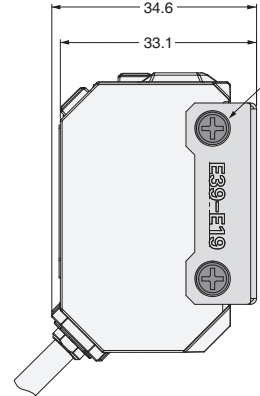
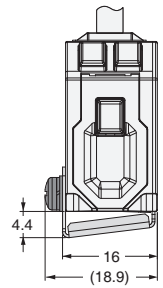

Material: Stainless steel (SUS304)

\* Accessories

2-M3-L10 Cross Recessed Pan Head Screws (Attached to SW+JIS W)







## E39-L212

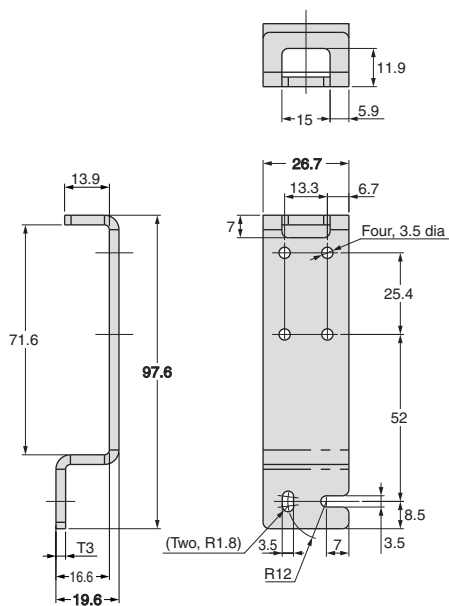

Photoelectric Sensor  
Accessory are installed  
(Example of E3AS-L200□)

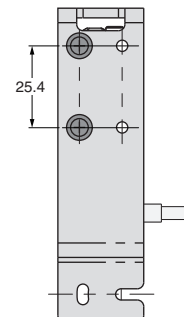
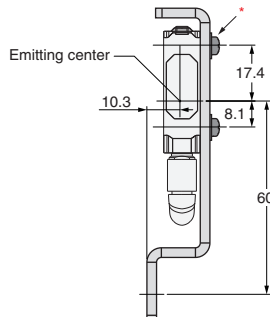
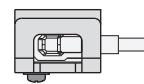

Material: Stainless steel (SUS304)

\* Accessories

2-M3-L12 Cross Recessed Pan Head Screws (Attached to SW+JIS W)

## E39-L214

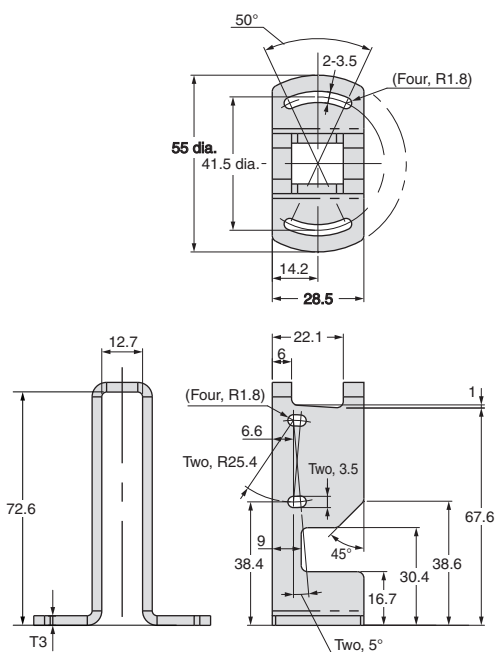

Photoelectric Sensor  
Accessory are installed  
(Example of E3AS-L200□)

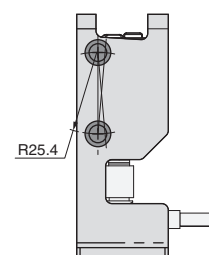
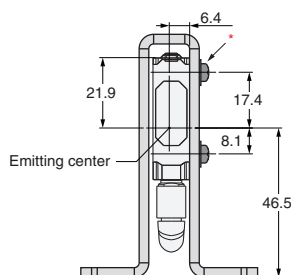
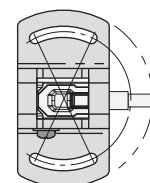

Material: Stainless steel (SUS304)

\* Accessories

2-M3-L12 Cross Recessed Pan Head Screws (Attached to SW+JIS W)

# E3AS Series

## Common to E3AS series

### Flexible Mounting Bracket E39-L261

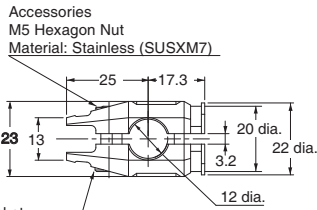

Accessories  
M5-L15 Hexagon Socket  
Head Cap Screws  
Material: Stainless (SUSXM7)

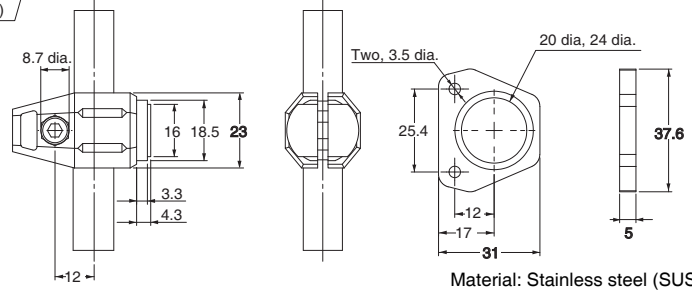

Material: ZDC2  
Finished: Ni Plating

Material: Stainless steel (SUS304)

### Photoelectric Sensor Accessory are installed (Example of E3AS-HL500□)

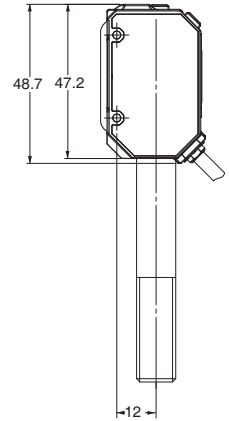
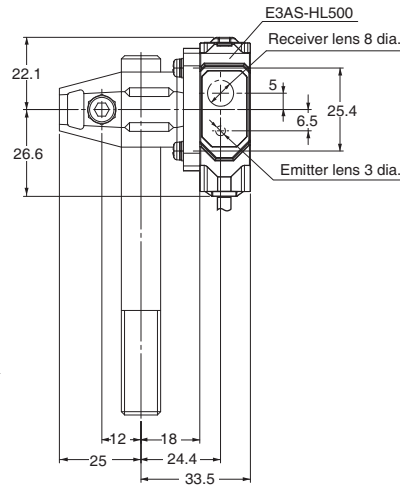
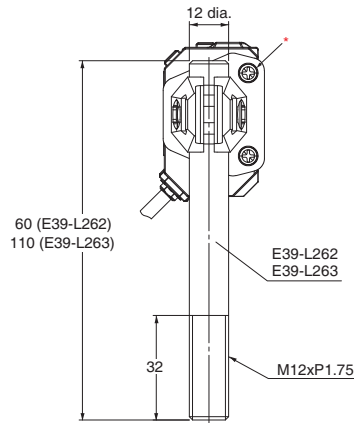
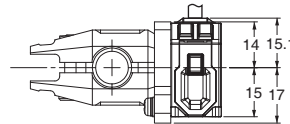

### Photoelectric Sensor Accessory are installed (Example of E3AS-HL500□)

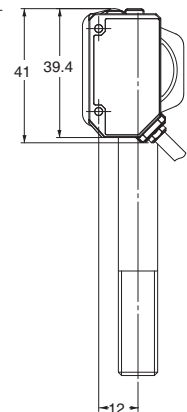
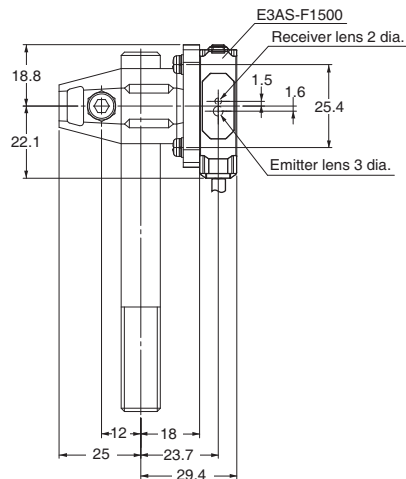
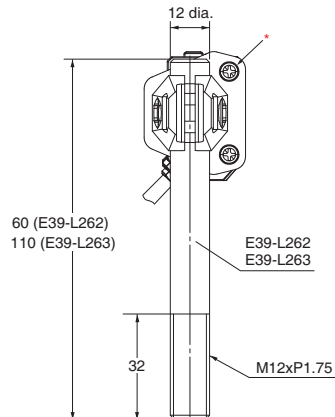
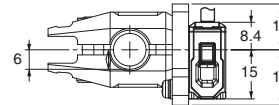

\* Accessories 2-M3-L10 Cross Recessed Pan Head Screws (Attached to SW+JIS)

**Post 50 mm  
E39-L262**

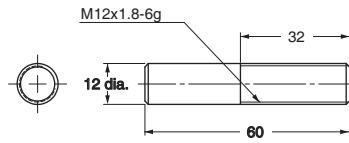

Accessories  
2-M12 Hexagon Nut  
Material: Stainless (SUSXM7)

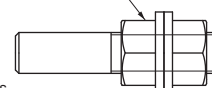

Accessories  
2-M12 Plain Washer  
Material: Stainless (SUS304)

Material: Stainless steel (SUS304)

**Post 100 mm  
E39-L263**

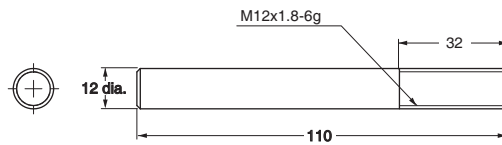

Accessories  
2-M12 Hexagon Nut  
Material: Stainless (SUSXM7)

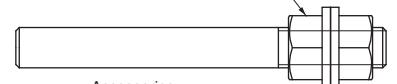

Accessories  
2-M12 Plain Washer  
Material: Stainless (SUS304)

Material: Stainless steel (SUS304)

# E3AS Series

## Air Blow Unit E39-E16

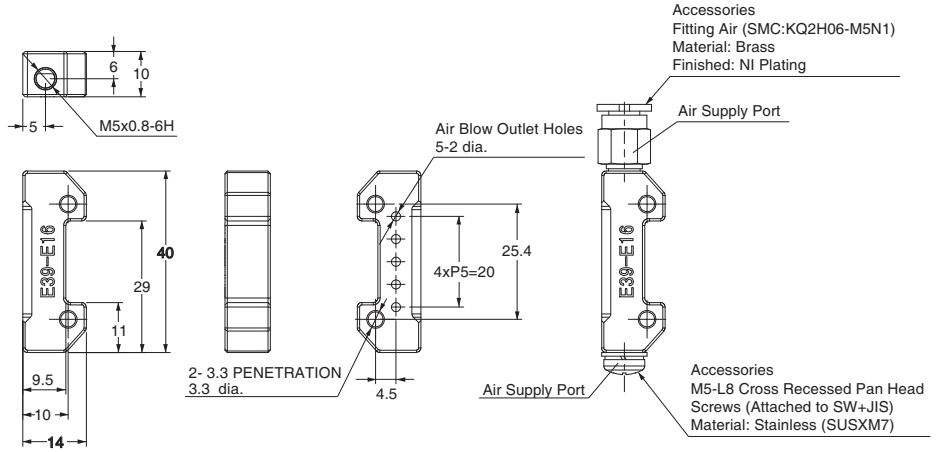

## Photoelectric Sensor Accessory are installed (Example of E3AS-HL500□)

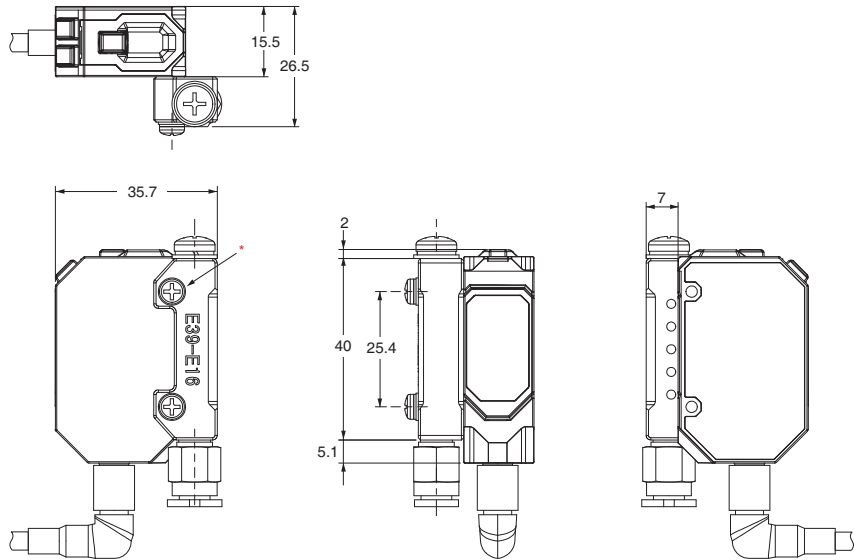

## Photoelectric Sensor Accessory are installed (Example of E3AS-HL500□)

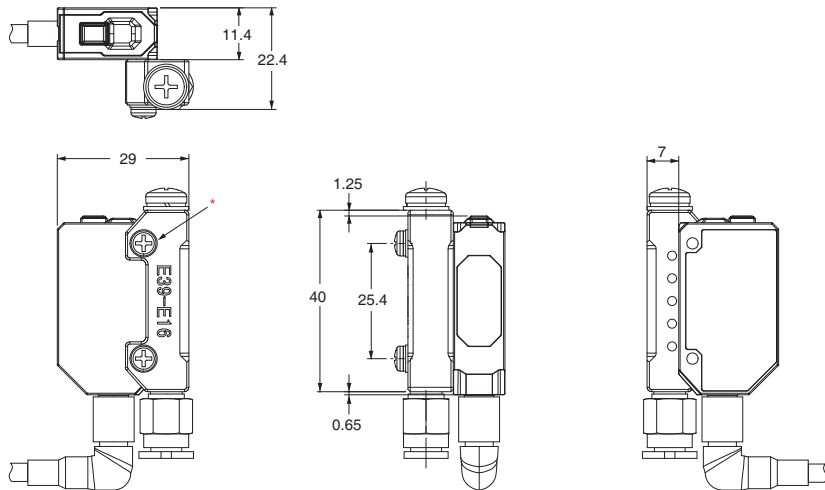

Material: ZDC2  
 Finished: NI Plating  
 \* Accessories 2-M3-L16 Cross Recessed Pan Head Screws (Attached to SW+JIS)

- EtherCAT® is a registered trademark and patented technology, licensed by Beckhoff Automation GmbH, Germany.
- EtherNet/IP™ is a trademark of ODVA.
- Ecolab and its logo are registered trademarks of Ecolab USA Inc.
- Smartclick is a registered trademark of OMRON Corporation.
- Other company names and product names in this document are the trademarks or registered trademarks of their respective companies.
- The product photographs and figures that are used in this catalog may vary somewhat from the actual products.



# Terms and Conditions Agreement

## **Read and understand this catalog.**

Please read and understand this catalog before purchasing the products. Please consult your OMRON representative if you have any questions or comments.

## **Warranties.**

(a) Exclusive Warranty. Omron's exclusive warranty is that the Products will be free from defects in materials and workmanship for a period of twelve months from the date of sale by Omron (or such other period expressed in writing by Omron). Omron disclaims all other warranties, express or implied.

(b) Limitations. OMRON MAKES NO WARRANTY OR REPRESENTATION, EXPRESS OR IMPLIED, ABOUT NON-INFRINGEMENT, MERCHANTABILITY OR FITNESS FOR A PARTICULAR PURPOSE OF THE PRODUCTS. BUYER ACKNOWLEDGES THAT IT ALONE HAS DETERMINED THAT THE PRODUCTS WILL SUITABLY MEET THE REQUIREMENTS OF THEIR INTENDED USE.

Omron further disclaims all warranties and responsibility of any type for claims or expenses based on infringement by the Products or otherwise of any intellectual property right. (c) Buyer Remedy. Omron's sole obligation hereunder shall be, at Omron's election, to (i) replace (in the form originally shipped with Buyer responsible for labor charges for removal or replacement thereof) the non-complying Product, (ii) repair the non-complying Product, or (iii) repay or credit Buyer an amount equal to the purchase price of the non-complying Product; provided that in no event shall Omron be responsible for warranty, repair, indemnity or any other claims or expenses regarding the Products unless Omron's analysis confirms that the Products were properly handled, stored, installed and maintained and not subject to contamination, abuse, misuse or inappropriate modification. Return of any Products by Buyer must be approved in writing by Omron before shipment. Omron Companies shall not be liable for the suitability or unsuitability or the results from the use of Products in combination with any electrical or electronic components, circuits, system assemblies or any other materials or substances or environments. Any advice, recommendations or information given orally or in writing, are not to be construed as an amendment or addition to the above warranty.

See <http://www.omron.com/global/> or contact your Omron representative for published information.

## **Limitation on Liability; Etc.**

OMRON COMPANIES SHALL NOT BE LIABLE FOR SPECIAL, INDIRECT, INCIDENTAL, OR CONSEQUENTIAL DAMAGES, LOSS OF PROFITS OR PRODUCTION OR COMMERCIAL LOSS IN ANY WAY CONNECTED WITH THE PRODUCTS, WHETHER SUCH CLAIM IS BASED IN CONTRACT, WARRANTY, NEGLIGENCE OR STRICT LIABILITY.

Further, in no event shall liability of Omron Companies exceed the individual price of the Product on which liability is asserted.

## **Suitability of Use.**

Omron Companies shall not be responsible for conformity with any standards, codes or regulations which apply to the combination of the Product in the Buyer's application or use of the Product. At Buyer's request, Omron will provide applicable third party certification documents identifying ratings and limitations of use which apply to the Product. This information by itself is not sufficient for a complete determination of the suitability of the Product in combination with the end product, machine, system, or other application or use. Buyer shall be solely responsible for determining appropriateness of the particular Product with respect to Buyer's application, product or system. Buyer shall take application responsibility in all cases.

NEVER USE THE PRODUCT FOR AN APPLICATION INVOLVING SERIOUS RISK TO LIFE OR PROPERTY OR IN LARGE QUANTITIES WITHOUT ENSURING THAT THE SYSTEM AS A WHOLE HAS BEEN DESIGNED TO ADDRESS THE RISKS, AND THAT THE OMRON PRODUCT(S) IS PROPERLY RATED AND INSTALLED FOR THE INTENDED USE WITHIN THE OVERALL EQUIPMENT OR SYSTEM.

## **Programmable Products.**

Omron Companies shall not be responsible for the user's programming of a programmable Product, or any consequence thereof.

## **Performance Data.**

Data presented in Omron Company websites, catalogs and other materials is provided as a guide for the user in determining suitability and does not constitute a warranty. It may represent the result of Omron's test conditions, and the user must correlate it to actual application requirements. Actual performance is subject to the Omron's Warranty and Limitations of Liability.

## **Change in Specifications.**

Product specifications and accessories may be changed at any time based on improvements and other reasons. It is our practice to change part numbers when published ratings or features are changed, or when significant construction changes are made. However, some specifications of the Product may be changed without any notice. When in doubt, special part numbers may be assigned to fix or establish key specifications for your application. Please consult with your Omron's representative at any time to confirm actual specifications of purchased Product.

## **Errors and Omissions.**

Information presented by Omron Companies has been checked and is believed to be accurate; however, no responsibility is assumed for clerical, typographical or proofreading errors or omissions.

## Related Products

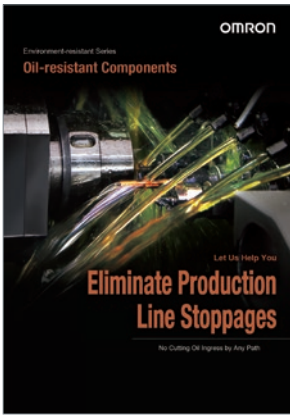

Environment-resistant Series Oil-resistant Components

Cat. No. Y215-E1



IO-Link Series

Cat. No. Y229-E1

**Note: Do not use this document to operate the Unit.**

**OMRON Corporation Industrial Automation Company**  
Kyoto, JAPAN

Contact: [www.ia.omron.com](http://www.ia.omron.com)

**Regional Headquarters**

**OMRON EUROPE B.V.**

Wegalaan 67-69, 2132 JD Hoofddorp  
The Netherlands  
Tel: (31)2356-81-300/Fax: (31)2356-81-388

**OMRON ASIA PACIFIC PTE. LTD.**

No. 438A Alexandra Road # 05-05/08 (Lobby 2),  
Alexandra Technopark,  
Singapore 119967  
Tel: (65) 6835-3011/Fax: (65) 6835-2711

**OMRON ELECTRONICS LLC**

2895 Greenspoint Parkway, Suite 200  
Hoffman Estates, IL 60169 U.S.A.  
Tel: (1) 847-843-7900/Fax: (1) 847-843-7787

**OMRON (CHINA) CO., LTD.**

Room 2211, Bank of China Tower,  
200 Yin Cheng Zhong Road,  
PuDong New Area, Shanghai, 200120, China  
Tel: (86) 21-5037-2222/Fax: (86) 21-5037-2200

**Authorized Distributor:**

© OMRON Corporation 2020-2021 All Rights Reserved.  
In the interest of product improvement,  
specifications are subject to change without notice.

CSM\_4\_1

Cat. No. E594-E1-04

1221 (1020)