

Environment-resistive Remote Terminal NXR-series IO-Link I/O Hub

NXR-□D166C-IL2

CSM_NXR-_D166C-IL2_DS_E_2_3

Reduced wiring system with IO-Link



Features

- IP67 protection
- Scalable digital inputs and outputs via IO-Link master
- Detection of disconnections or short circuits in I/O cables to connect external devices
- Monitors power supply voltage for the unit and inputs and power supply voltage for outputs

System Configuration

System Configuration

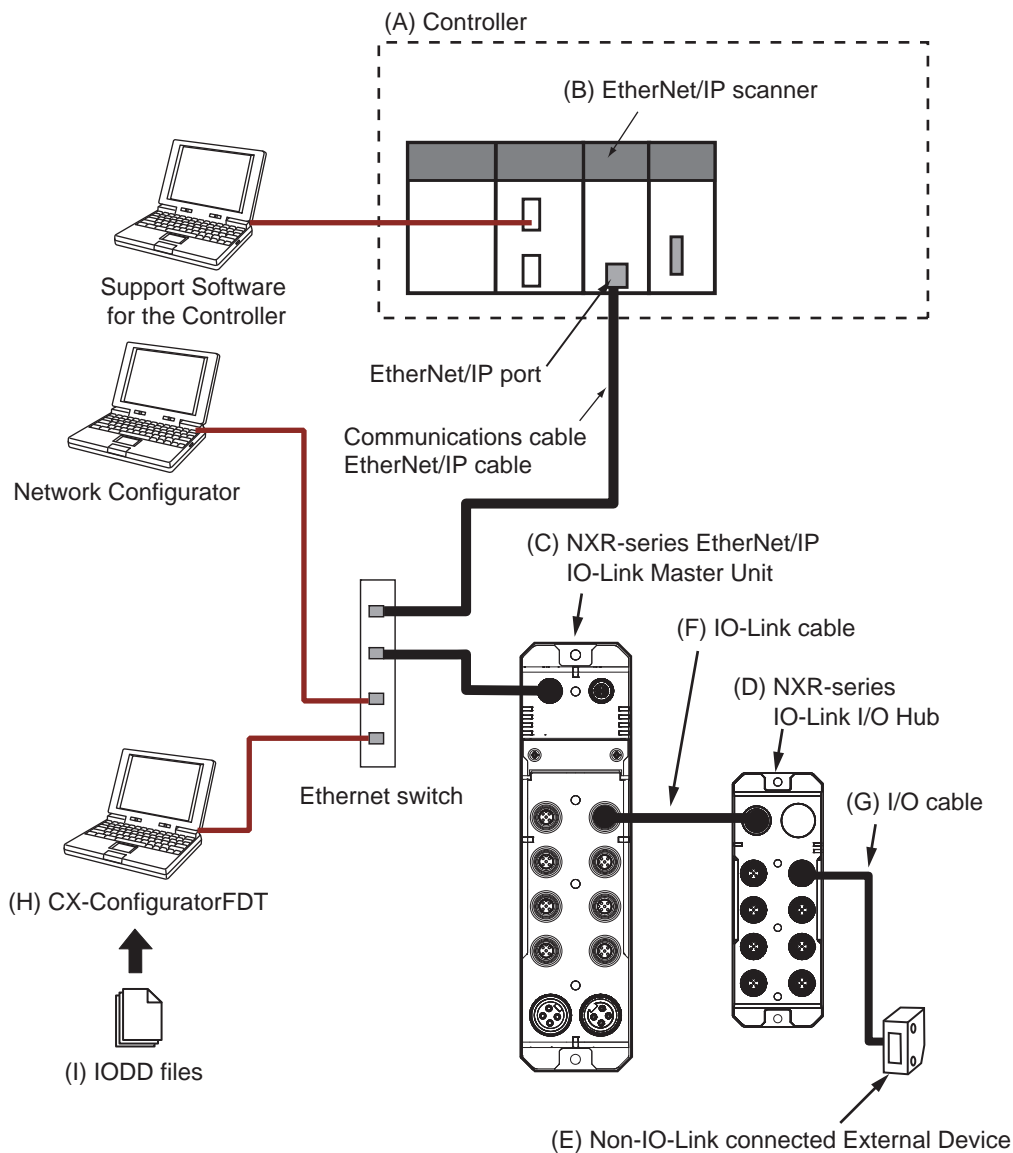

Letter	Name	Function
(A)	Controller	This is an OMRON CPU Unit or a controller from another company, connected to the IO-Link Master Unit through an EtherNet/IP adapter.
(B)	EtherNet/IP scanner	The EtherNet/IP scanner monitors the status of the connections with EtherNet/IP adapters and exchanges I/O data with EtherNet/IP adapters through the EtherNet/IP network.
(C)	NXR-series EtherNet/IP IO-Link Master Unit	An EtherNet/IP adapter that provides IO-Link master functions with an environmental resistance of IP67. The Unit performs the following: <ul style="list-style-type: none"> Exchanging data with the EtherNet/IP scanner through the EtherNet/IP network Exchanging data with the NXR-series IO-Link I/O Hub through IO-Link communications
(D)	NXR-series IO-Link I/O Hub	An IO-Link I/O device. The Hub exchanges I/O data from the external devices connected to it with the IO-Link Master Unit through IO-Link communications.
(E)	Non-IO-Link connected External Device	A Sensor, actuator, or other device that handles ON/OFF signals.
(F)	IO-Link cable	A cable that connects an IO-Link Master Unit to an IO-Link I/O Hub.
(G)	I/O cable	A cable that connects an IO-Link I/O Hub to a non-IO-Link connected external device.
(H)	CX-ConfiguratorFDT *1	A Support Software to configure and monitor IO-Link I/O Hubs. The software is included in the CX-One Automation Software Suite and the Sysmac Studio Automation Software.
(I)	IODD files	These files contain IO-Link device definitions.

*1. For available versions, refer to *Version Information* on page 9.

Ordering Information

Applicable standards

Refer to the OMRON website (www.ia.omron.com) or ask your OMRON representative for the most recent applicable standards for each model.

NXR-series IO-Link I/O Hub

Product name	Number of IO-Link ports	Input/Output	Degree of protection	I/O connection terminals	Model
IO-Link I/O Hub	8	16 digital inputs	IP67	M12 connector A-cording, female	NXR-ID166C-IL2
		16 digital inputs/outputs			NXR-CD166C-IL2

NXR-series IO-Link Master Unit for EtherNet/IP™

Product name	Number of IO-Link ports	Degree of protection	I/O connection terminals	Model
IO-Link Master Unit for EtherNet/IP	8	IP67	M12 connector A-cording, female	NXR-ILM08C-EIT

Software

FA Integrated Tool Package CX-One

Product name	Specifications			Model
		Number of licenses	Media	
FA Integrated Tool Package CX-One Ver.4.□	<p>The CX-One is a comprehensive software package that integrates Support Software for OMRON PLCs and components.</p> <p>CX-One runs on the following OS. Windows XP (Service Pack 3 or higher, 32-bit version) / Windows Vista (32-bit/64-bit version) / Windows 7 (32-bit/64-bit version) / Windows 8 (32-bit/64-bit version) / Windows 8.1 (32-bit/64-bit version) / Windows 10 (32-bit/64-bit version)</p> <p>CX-One Version 4.□ includes CX-Programmer Ver.9.□ For details, refer to the <i>CX-One catalog</i> (Cat. No. R134)</p>	1 license *1	DVD	CXONE-AL01D-V4

*1 Multi licenses (3, 10, 30, or 50 licenses) and DVD media without licenses are also available for the CX-One.

Automation Software Sysmac Studio

Please purchase a DVD and required number of licenses the first time you purchase the Sysmac Studio. DVDs and licenses are available individually. Each model of licenses does not include any DVD.

Product name	Specifications			Model
		Number of licenses	Media	
Sysmac Studio Standard Edition Ver.1.□	<p>The Sysmac Studio is the software that provides an integrated environment for setting, programming, debugging and maintenance of machine automation controllers including NJ/NX-series CPU Units, NY-series Industrial PC, EtherCAT Slaves, and HMI.</p> <p>Sysmac Studio runs on the following OS. *1 Windows 7 (32-bit/64-bit version) / Windows 8.1 (32-bit/64-bit version) / Windows 10 (32-bit/64-bit version) / Windows 11 (64-bit version)</p>	– (Media only)	Sysmac Studio (32 bit) DVD	SYSMAC-SE200D
			Sysmac Studio (64 bit) DVD	SYSMAC-SE200D-64
	<p>The Sysmac Studio Standard Edition DVD includes Support Software to set up EtherNet/IP Units, DeviceNet slaves, Serial Communications Units, and Support Software for creating screens on HMIs (CX-Designer). For details, refer to your OMRON website.</p>	1 license *2	–	SYSMAC-SE201L

*1. SYSMAC-SE200D-64 runs on Windows 10 (64 bit) or higher.

*2. Multi licenses are available for the Sysmac Studio (3, 10, 30, or 50 licenses).

IO-Link Cables

Cables to connect the IO-Link master unit with an M12 plug

Name and appearance	Manufacturer	Specification	No. of cable conductors	Connector	Cable connection direction	Cable length	Model
XS2W Socket and Plug on Cable Ends (M12 (Socket)/M12 (Plug)) 	OMRON	M12 socket (A-coding, female) to M12 plug (A-coding, male), DC type	4	Screw connector	Straight/straight	1 m	XS2W-D421-C81-F
						2 m	XS2W-D421-D81-F
						3 m	XS2W-D421-E81-F
						5 m	XS2W-D421-G81-F
						10 m	XS2W-D421-J81-F

I/O Cables

- Connection conversion

Conversion cables to connect an external device with an M8 plug to the IO-Link I/O hub

Name and appearance	Manufacturer	Specification	No. of cable conductors	Connector	Cable connection direction	Cable length	Model
XS3W Socket and Plug on Cable Ends (M8 (Socket)/M12 (Plug)) 	OMRON	M8 socket (A-coding, female) to M12 plug (A-coding, male), DC type	4	(M8) screw connector, (M12) Smartclick connector *1	Straight	0.2 m	XS3W-M42C-4C2-A

*1. The IO-Link I/O hub does not use a Smartclick connector. Use a torque wrench for the I/O cable to tighten the connector. The Smartclick connector of the I/O cable can also be used as a screw connector.

- Branching

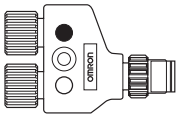
Name and appearance	Manufacturer	Specification	No. of cable conductors	Connector	Cable connection direction	Cable length	Model
XS5R Y-Joint Plug/Socket Connector 	OMRON	M12	---	Smartclick Connector *1	---	---	XS5R-D426-1

*1. The IO-Link I/O hub does not use a Smartclick connector. Use a torque wrench for the I/O cable to tighten the connector.

Waterproof Cover for Connectors

A waterproof cover for unused M12 connectors. When you use this waterproof cover, you can maintain the IP67 protective structure.

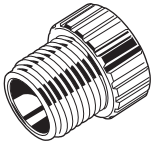
Name and appearance	Manufacturer	Specification	Connector	Model
M12 Waterproof Cover 	OMRON	M12	Screw connector	XS2Z-22

General Specifications

Item	Specification	
Degree of protection	IP67	
Operating environment	Ambient operating temperature	-10 to 55°C
	Ambient operating humidity	25% to 85% (with no condensation)
	Ambient operating atmosphere	Must be free from corrosive gases.
	Storage temperature	-25 to 65°C
	Storage humidity	25% to 85% (with no condensation)
	Altitude	2,000 m max.
	Pollution degree	3 or less: Conforms to IEC 61010-2-201.
	Noise immunity	2 kV on power supply line (Conforms to IEC 61000-4-4.)
	Overvoltage category	Category II: Conforms to IEC 61010-2-201
	EMC immunity level	Zone B
	Vibration resistance	10 to 60 Hz with amplitude of 0.35 mm, 60 to 150 Hz and 50 m/s ² for 80 minutes each in X, Y, and Z directions.
Shock resistance	150 m/s ² , 3 times each in 6 directions along X, Y, and Z axes	
Applicable standards *1	cULus: Listed (UL61010-2-201) EU: EN 61131-2, RCM KC: KC Registration EAC IO-Link conformance	

*1. Refer to the OMRON website (www.ia.omron.com) or ask your OMRON representative for the most recent applicable standards for each model.

NXR-□D166C-IL2

Individual Specifications

Item	Model	Specification	
		NXR-ID166C-IL2	NXR-CD166C-IL2
Device type		Digital Input Hub	Digital I/O Variable Hub
Unit/input power supply voltage		24 VDC (20.4 to 26.4 VDC)	
Current consumption from Unit/input power supply		40 mA max.	
Maximum current of Unit/input power supply		0.84 A	
Output power supply voltage		---	24 VDC (20.4 to 26.4 VDC)
Current consumption from output power supply		---	40 mA max.
Maximum current of output power supply		---	2.0 A
Dimensions		174 × 24.2 × 62 mm (W × H × D) (The height is 37.8 mm when the connectors are included.)	
Isolation method		No isolation	
Weight		280 g	

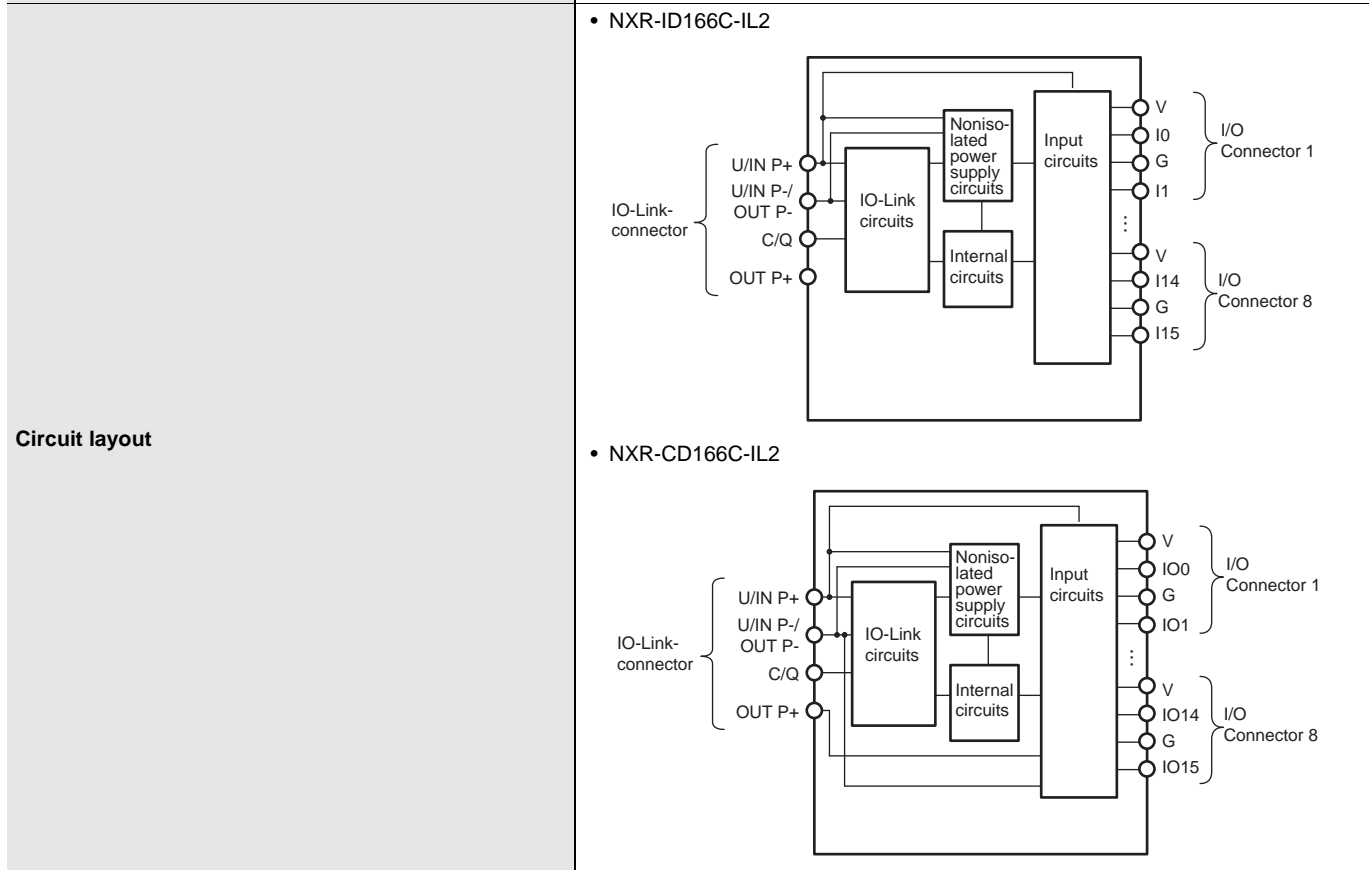

Item		Specification	
		NXR-ID166C-IL2	NXR-CD166C-IL2
IO-Link specifications	Model		
	Communications protocol	IO-Link protocol	
	Frame type	2.6 (Model: Digital Input Hub)	2.2 (Model number: Digital I/O Variable Hub)
	Baud rate	COM2: 38.4 kbps	
		Start-stop synchronization UART	
		1:1	
	Communications distance	20 m max.	
	Data in order	Big endian	
	Synchronization method	ISDU (Indexed Service Data Unit)	
	Minimum cycle time	10 ms	
	Process input data size	20 bytes	
	Process output data size	---	2 bytes
	M-sequence	TYPE_2_V	TYPE_2_V
	Vendor ID1	02 hex	02 hex
	Vendor ID2	64 hex	64 hex
	Vendor name	OMRON Corporation	OMRON Corporation
	Vendor text	OMRON Corporation	OMRON Corporation
	Device ID1	05 hex	05 hex
	Device ID2	00 hex	00 hex
Device ID3	01 hex	02 hex	
Product name	NXR-ID166C-IL2	NXR-CD166C-IL2	
Product ID	NXR-ID166C-IL2	NXR-CD166C-IL2	
Product text	IO-Link I/O Hub	IO-Link I/O Hub	

Item	Model	Specification	
		NXR-ID166C-IL2	NXR-CD166C-IL2
Mounting specifications	Mounting method	Mounting with M5 screws	
	Mounting strength	100 N	
	Connector strength	30 N Applicable to all connectors	
	Connector type	<ul style="list-style-type: none"> IO-Link connector: M12 (A-coding, male) I/O connector: M12 (A-coding, female) × 8 	
	Screw tightening torque	<ul style="list-style-type: none"> IO-Link connector and I/O connector (M12 screw) : 0.5 to 0.6 N·m Hub mounting (M5 screw) : 1.47 to 1.96 N·m 	
	Installation orientation and restrictions	<ul style="list-style-type: none"> Installation orientation: 6 possible orientations Restrictions: No restrictions 	
Digital input	Number of inputs	16	0 to 16 (variable)
	Internal I/O common	PNP	
	ON voltage/ON current	15 VDC min., 3 mA min. (between each input terminal and G)	
	OFF voltage/OFF current	5 VDC max., 1 mA max. (between each input terminal and G)	
	Input current	4.0 mA (for 24 VDC)	
	Sensor power supply current	100 mA max./port	
	ON response time	0.1 ms max.	
	OFF response time	0.2 ms max.	
	Input filter	0 ms, 0.5 ms, 1 ms (default), 2 ms, 4 ms, 8 ms, 16 ms, 32 ms, 64 ms, 128 ms	
	Short-circuit protection	Provided *1	
	Short-circuit detection	Provided *1	
	Line disconnection detection	Provided *2	
Digital output	Number of outputs	---	0 to 16 (variable)
	Maximum load current	---	500 mA/point
	OFF leakage current	---	0.3 mA max.
	Internal I/O common	---	PNP
	ON response time	---	0.5 ms max.
	OFF response time	---	1.5 ms max.
	Residual voltage	---	1.2 V max. (0.5 ADC, between each output terminal and G)
	Short-circuit protection	---	Provided *3
	Short-circuit detection	---	Provided *3
	Line disconnection detection	---	Provided *4

*1. Detects a short-circuit that occurred between the V and G power supply terminals of the I/O connectors to protect the IO-Link I/O Hubs.

*2. Detects a disconnection of the V power supply terminal of the I/O connectors.

*3. Detects a short-circuit that occurred between pin 4 and the G power supply terminal and between pin 2 and the G power supply terminal to protect the IO-Link I/O Hubs.

*4. Detects a disconnection of pin 4 and pin 2 of the I/O connectors.

Version Information

The following table shows the relationship between the unit versions of the IO-Link I/O Hub and NXR-series EtherNet/IP IO-Link Master Unit, and the corresponding support software versions. With the combinations of the versions that are the same as or later (higher) than the versions in the table below, you can use all the functions that are supported by each unit version of the IO-Link I/O Hub.

IO-Link I/O Hub		NXR-series EtherNet/IP IO-Link Master Unit	Support software
Model	Unit version	NXR-ILM08C-EIT	CX-ConfiguratorFDT
NXR-ID166C-IL2	Ver.1.0	Ver.1.0	Ver.2.54
NXR-CD166C-IL2	Ver.1.0	Ver.1.0	Ver.2.54

External Interface

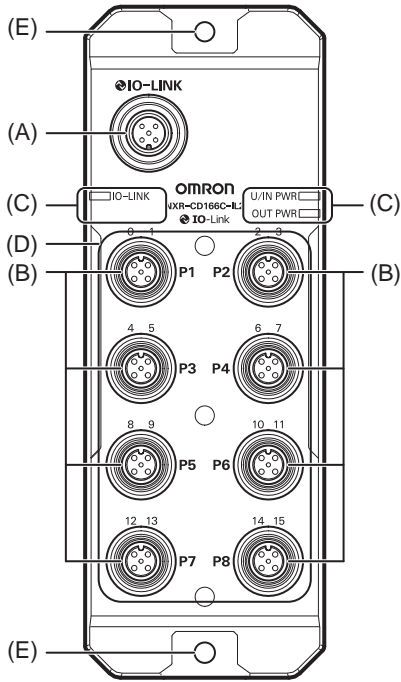

Letter	Name	Function
(A)	IO-Link connector	The connector connects the Hub to the IO-Link Master Unit. <ul style="list-style-type: none"> • M12 connector (A-coding, male) Connect an IO-Link cable. Applications: <ul style="list-style-type: none"> • IO-Link communications with the IO-Link Master Unit • Supplying the Unit/input power to the Digital I/O Hub*1 • Supplying the output power to the Digital I/O Variable Hub*1
(B)	I/O connectors	The connectors connect the Hub to the connected external devices. The connectors are called "port"s. <ul style="list-style-type: none"> • M12 connectors (A-coding, female) Connect I/O cables.
(C)	Status indicators	The indicators that show the current operating status of the Digital I/O Hub.
(D)	I/O indicators	The indicators that show the status of pin 4/pin 1 and pin 2 for each port.
(E)	Hub mounting	The holes for mounting the Digital I/O Hub. They are provided in two locations. Mount the Hub with M5 screws.

*1. This is supplied from the IO-Link Master Unit through the IO-Link cable.

Dimensions

(Unit: mm)

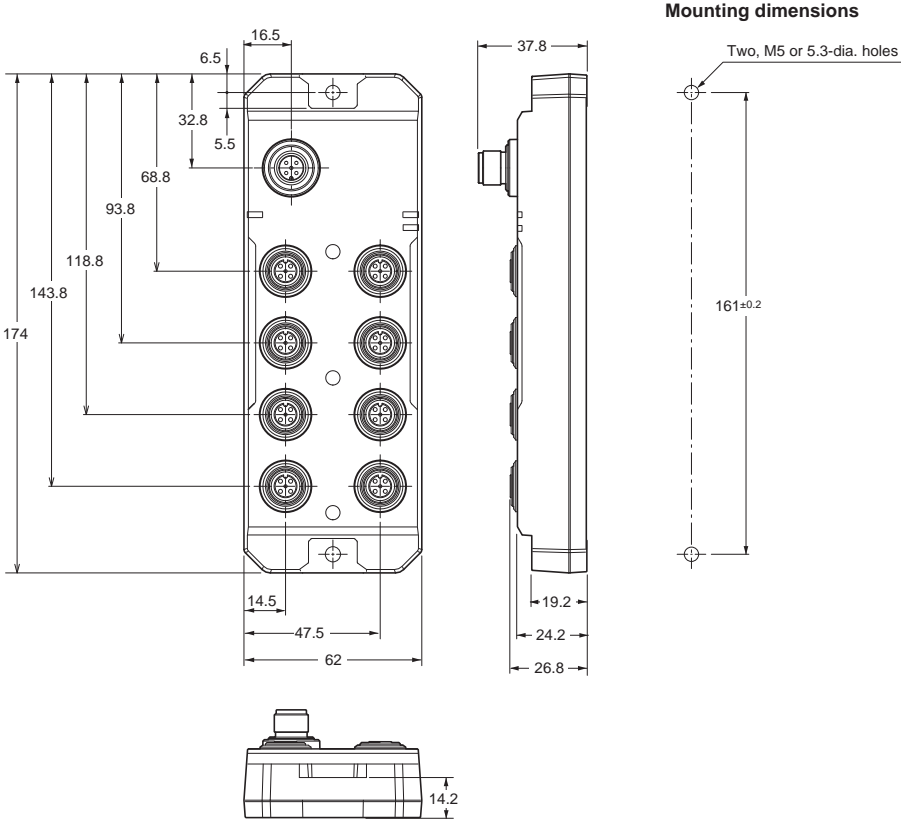

Wiring Example for I/O Connectors

Wiring Example for Two-wire Sensors

A wiring example for a 2-wire sensor to an input of the Digital I/O Hub is given below. In this example, pin 4 of port 1 serves as an input.

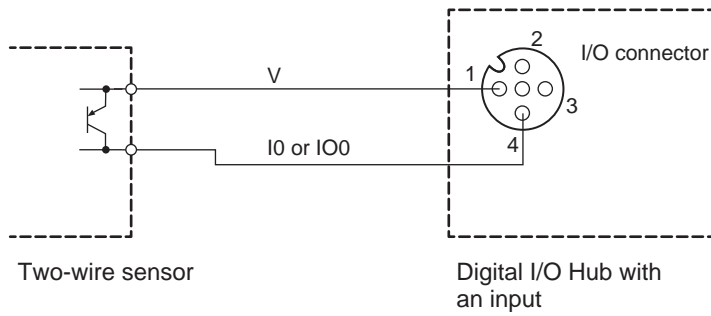

The power to pin 1, or +(V), is supplied from the IO-Link Master Unit through the IO-Link cable to the Digital I/O Hub.

Wiring Example for Three-wire Sensors

A wiring example for a 3-wire sensor to an input of the Digital I/O Hub is given below. In this example, pin 4 of port 1 serves as an input.

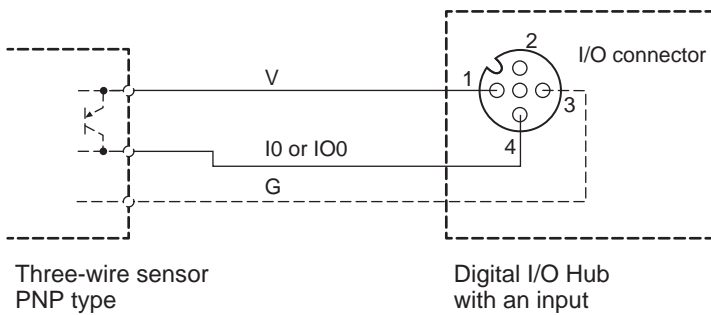

The power to pin 1, or +(V), is supplied from the IO-Link Master Unit through the IO-Link cable to the Digital I/O Hub.

Wiring Example for an Output Device

A wiring example for output device to an output of the Digital I/O Hub is given below. In this example, pin 4 of port 1 serves as an output.

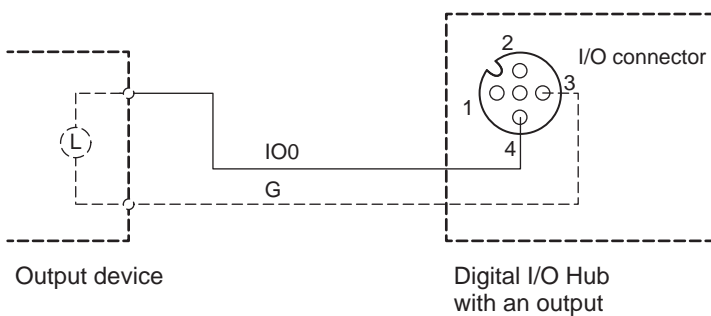

The output power that provides load current is supplied from the IO-Link Master Unit through the IO-Link cable to the Digital I/O Hub.

Power Supply System

The following shows the power supply system for the IO-Link I/O Hubs. The Unit/input power and output power are supplied from the IO-Link Master Unit, which is connected to an external power supply, through the IO-Link cable to the IO-Link I/O Hub.

Digital Input Hub (NXR-ID166C-IL2)

The Digital Input Hub does not require the output power to be supplied to the Hub.

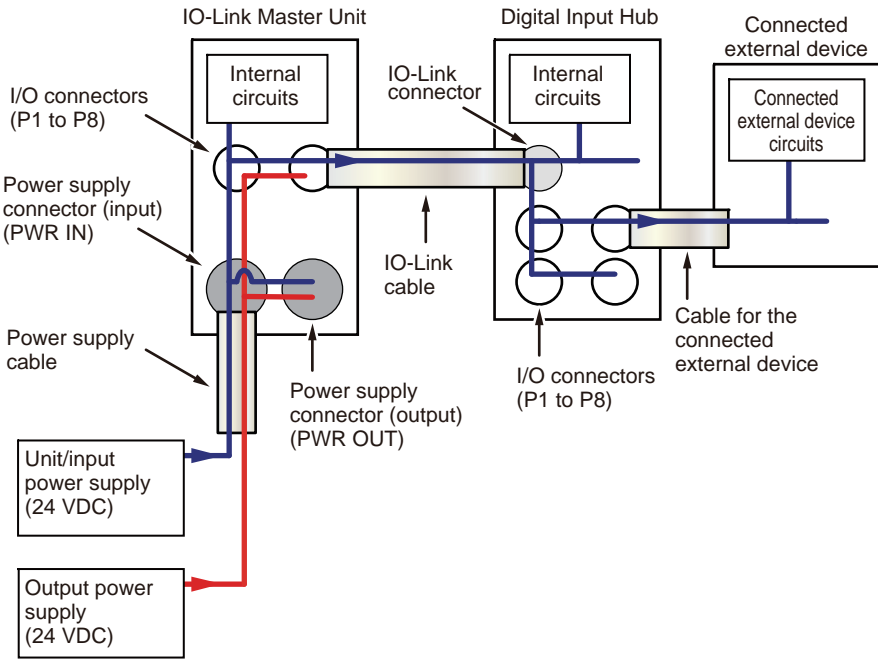

Digital I/O Variable Hub (NXR-CD166C-IL2)

Set pin 2 of the port of the IO-Link Master Unit to SIO (DO) Mode, and turn on the output of pin 2. (See following figure (A).)

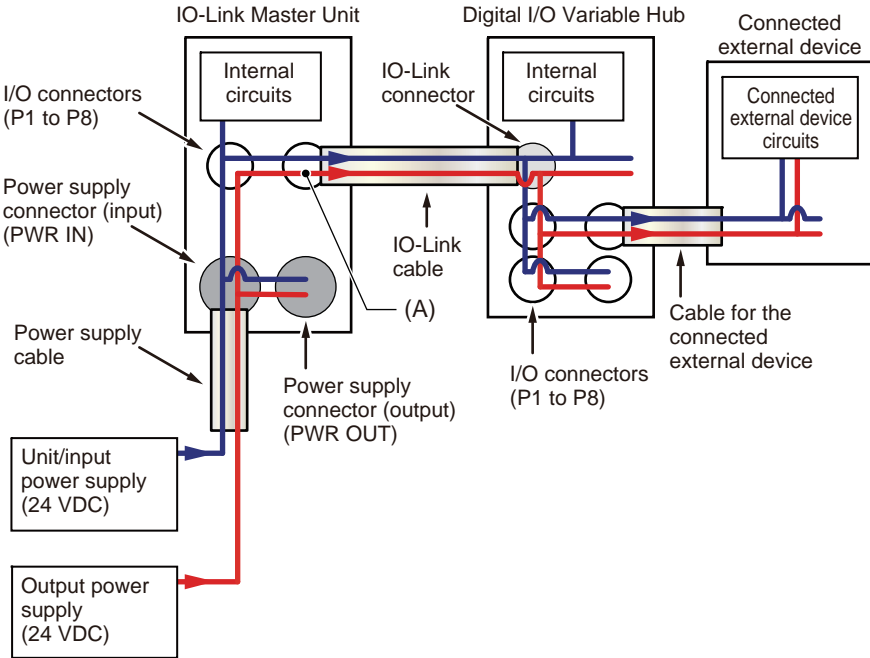

NXR-□D166C-IL2

Related Manuals

Manual	Cat. No	Model	Application	Description
NXR-series IO-Link I/O Hub User's Manual	W620	NXR-□□□□□□-IL□	Learning how to use an NXR-series IO-Link I/O Hub.	Describes the hardware, setup methods, and functions of the NXR-series IO-Link I/O Hub.
NXR-series IO-Link Master Unit for EtherNet/IP™ User's Manual	W619	NXR-ILM08C-EIT	Learning how to use an NXR-series IO-Link Master Unit for EtherNet/IP.	Describes the hardware, setup methods, and functions of the NXR-series IO-Link Master Unit for EtherNet/IP.

SyMac is a trademark or registered trademark of OMRON Corporation in Japan and other countries for OMRON factory automation products. Microsoft and Windows are either registered trademarks or trademarks of Microsoft Corporation in the United States and/or other countries. EtherCAT® is a registered trademark and patented technology, licensed by Beckhoff Automation GmbH, Germany. EtherNet/IP™ is a trademark of ODVA. Other company names and product names in this document are the trademarks or registered trademarks of their respective companies.

Terms and Conditions Agreement

Read and understand this catalog.

Please read and understand this catalog before purchasing the products. Please consult your OMRON representative if you have any questions or comments.

Warranties.

(a) Exclusive Warranty. Omron's exclusive warranty is that the Products will be free from defects in materials and workmanship for a period of twelve months from the date of sale by Omron (or such other period expressed in writing by Omron). Omron disclaims all other warranties, express or implied.

(b) Limitations. OMRON MAKES NO WARRANTY OR REPRESENTATION, EXPRESS OR IMPLIED, ABOUT NON-INFRINGEMENT, MERCHANTABILITY OR FITNESS FOR A PARTICULAR PURPOSE OF THE PRODUCTS. BUYER ACKNOWLEDGES THAT IT ALONE HAS DETERMINED THAT THE PRODUCTS WILL SUITABLY MEET THE REQUIREMENTS OF THEIR INTENDED USE.

Omron further disclaims all warranties and responsibility of any type for claims or expenses based on infringement by the Products or otherwise of any intellectual property right. (c) Buyer Remedy. Omron's sole obligation hereunder shall be, at Omron's election, to (i) replace (in the form originally shipped with Buyer responsible for labor charges for removal or replacement thereof) the non-complying Product, (ii) repair the non-complying Product, or (iii) repay or credit Buyer an amount equal to the purchase price of the non-complying Product; provided that in no event shall Omron be responsible for warranty, repair, indemnity or any other claims or expenses regarding the Products unless Omron's analysis confirms that the Products were properly handled, stored, installed and maintained and not subject to contamination, abuse, misuse or inappropriate modification. Return of any Products by Buyer must be approved in writing by Omron before shipment. Omron Companies shall not be liable for the suitability or unsuitability or the results from the use of Products in combination with any electrical or electronic components, circuits, system assemblies or any other materials or substances or environments. Any advice, recommendations or information given orally or in writing, are not to be construed as an amendment or addition to the above warranty.

See <http://www.omron.com/global/> or contact your Omron representative for published information.

Limitation on Liability: Etc.

OMRON COMPANIES SHALL NOT BE LIABLE FOR SPECIAL, INDIRECT, INCIDENTAL, OR CONSEQUENTIAL DAMAGES, LOSS OF PROFITS OR PRODUCTION OR COMMERCIAL LOSS IN ANY WAY CONNECTED WITH THE PRODUCTS, WHETHER SUCH CLAIM IS BASED IN CONTRACT, WARRANTY, NEGLIGENCE OR STRICT LIABILITY.

Further, in no event shall liability of Omron Companies exceed the individual price of the Product on which liability is asserted.

Suitability of Use.

Omron Companies shall not be responsible for conformity with any standards, codes or regulations which apply to the combination of the Product in the Buyer's application or use of the Product. At Buyer's request, Omron will provide applicable third party certification documents identifying ratings and limitations of use which apply to the Product. This information by itself is not sufficient for a complete determination of the suitability of the Product in combination with the end product, machine, system, or other application or use. Buyer shall be solely responsible for determining appropriateness of the particular Product with respect to Buyer's application, product or system. Buyer shall take application responsibility in all cases.

NEVER USE THE PRODUCT FOR AN APPLICATION INVOLVING SERIOUS RISK TO LIFE OR PROPERTY OR IN LARGE QUANTITIES WITHOUT ENSURING THAT THE SYSTEM AS A WHOLE HAS BEEN DESIGNED TO ADDRESS THE RISKS, AND THAT THE OMRON PRODUCT(S) IS PROPERLY RATED AND INSTALLED FOR THE INTENDED USE WITHIN THE OVERALL EQUIPMENT OR SYSTEM.

Programmable Products.

Omron Companies shall not be responsible for the user's programming of a programmable Product, or any consequence thereof.

Performance Data.

Data presented in Omron Company websites, catalogs and other materials is provided as a guide for the user in determining suitability and does not constitute a warranty. It may represent the result of Omron's test conditions, and the user must correlate it to actual application requirements. Actual performance is subject to the Omron's Warranty and Limitations of Liability.

Change in Specifications.

Product specifications and accessories may be changed at any time based on improvements and other reasons. It is our practice to change part numbers when published ratings or features are changed, or when significant construction changes are made. However, some specifications of the Product may be changed without any notice. When in doubt, special part numbers may be assigned to fix or establish key specifications for your application. Please consult with your Omron's representative at any time to confirm actual specifications of purchased Product.

Errors and Omissions.

Information presented by Omron Companies has been checked and is believed to be accurate; however, no responsibility is assumed for clerical, typographical or proofreading errors or omissions.